

SQ-R

Discharge Measurement System

Manual

Setup version 2.41 (Firmware 3.07)

09.06.2022



Sommer Messtechnik

All rights reserved.

The Copyrights for this manual are exclusively owned by

Sommer Messtechnik
6842 Koblach
Austria

This manual or parts of it may only be copied or passed on to third parties with written permission of Sommer Messtechnik. This applies to printed as well as digital issues of this manual.



Sommer Messtechnik
Strassenhäuser 27
6842 Koblach
Austria
www.sommer.at
E office@sommer.at
T +43 5523 55989
F +43 5523 55989-19

Validity

This manual applies to the Discharge Measurement System with the setup version 2.41, including all its subversions.

Created: 04.11.2020

Last update: 09.06.2022

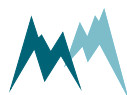

EU conformity



This product is in conformity with the following standards:

EMC	2014/30/EU	EN 301 489-1 V1.9.2
LVD	2014/35/EU	EN 62311:2008
		EN 62368-1:2014
RED	2014/53/EU	EN 300 440-2 V1.4.1
RoHS II	2011/65/EU	
RoHS III	2015/863/EU	

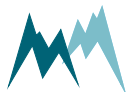

Safety information

Please read this manual carefully before installing or operating this equipment. Non-compliance with the instructions given in this manual can result in failure or damage of the equipment or may put people at risk by injuries through electrical or mechanic impact.

- Make sure that the personnel responsible for installation, configuration and maintenance is familiar with the applicable regulations and standards!
- Installation of equipment on towers, bridges and in discharge channels poses the risk of falling, slipping or dropping of objects. Contact your safety officer or consult applicable safety regulations for precautions and proper personal safety equipment.
- Do not perform any installations in bad weather conditions, e.g. thunderstorms.
- Prior to installation of equipment inform the owner of the measurement site or the authority responsible for it. Upon completion, secure the installation from trespassers.
- Maintenance and repair must be performed by trained personnel or an engineer of Sommer Messtechnik. Only replacement parts supplied by Sommer Messtechnik should be used for repairs.
- Make sure that NO power is connected to the equipment during installation and wiring!
- Only use a power supply that complies with the power rating specified for this equipment!
- Keep equipment dry during wiring and maintenance!
- If applicable, it is recommended to use accessories of Sommer Messtechnik with this equipment.

Disposal



After this device has reached the end of its lifetime, it must not be disposed of with household waste! Instead, dispose of the device by returning it to a designated collection point for the recycling of waste electrical and electronic equipment.



Feedback

Should you come across any error in this manual, or if you miss information to handle and operate the SQ-R we are pleased to receive your feedback to office@sommer.at.

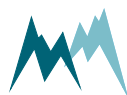

Content

- 1 What is the SQ-R? 12
- 2 Unpacking 14
- 3 Get started 15
 - 3.1 Connect the SQ-R to your PC 15
 - 3.2 Configure the SQ-R 15
 - 3.3 Adjust the SQ-R to the current water level 16
 - 3.4 Acquire measurements 16
- 4 How the SQ-R works 17
 - 4.1 Water level 17
 - 4.1.1 Definition 17
 - 4.1.2 Principle of measurement 17
 - 4.2 Flow velocity 18
 - 4.2.1 Principle of measurement 18
 - 4.2.2 Flow direction separation 18
 - 4.2.3 Inclination angle measurement 19
 - 4.2.4 Conditions of the water surface 19
 - 4.2.5 Radar spectrum 19
 - 4.3 Determination of water discharge 20
 - 4.3.1 Base equation 20
 - 4.3.2 k-Factors 21
 - 4.3.3 Cross-Sectional area 21
 - 4.3.4 Discharge calculation 21
- 5 Components 23
 - 5.1 Velocity sensor 23
 - 5.2 Level sensor 23
 - 5.3 Main connector 23
- 6 Specifications 25
- 7 Installation 27
 - 7.1 Site selection 27
 - 7.1.1 Hydraulic requirements 27
 - 7.1.2 Installation requirements 29
 - 7.1.3 Documentation 32
 - 7.2 Performing a site survey 32
 - 7.3 Things to consider for installation 37
 - 7.3.1 Power supply 37
 - 7.3.2 Signal cables 37
 - 7.3.3 Lightning protection 38

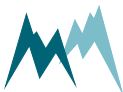

7.4	Required tools and equipment	38
7.5	Mounting	38
7.5.1	How do I install the SQ-R in a manhole?	39
7.6	Wiring	40
7.6.1	RS-485 wiring	40
7.6.2	SDI-12 wiring	41
7.6.3	How to wire analog outputs	41
7.7	Adjustment of water level	42
7.8	Start-up	42
8	Operation	43
8.1	Connect device to PC	43
9	Maintenance	44
9.1	Device status	44
10	Support software SQ-Commander	53
10.1	Software features	53
10.2	System requirements	53
10.3	Installation of SQ-Commander	53
10.4	Sign-in to SQ-Commander	58
10.5	Working with the SQ-Commander	58
10.6	Working with data loggers	58
11	Configuration of the SQ-R	59
11.1	Software tools	59
11.2	Conflict messages	59
11.2.1	Setup conflicts	59
11.3	General settings	60
11.3.1	Measurement trigger	60
11.3.2	Language/Sprache	61
11.3.3	Decimal character	61
11.3.4	Units and decimals	61
11.3.5	Output protocol (OP)	61
11.3.6	Information	61
11.4	Water level measurement	62
11.4.1	WMA, maximum level	62
11.4.2	WLL, low level border	62
11.4.3	WCF, cease to flow level	62
11.4.4	Adjustment	63
11.5	Velocity measurement	65
11.5.1	Viewing direction	65
11.5.2	Possible flow directions	65
11.5.3	Measurement duration	65
11.5.4	Minimum velocity	65

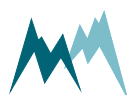

11.5.5	Maximum velocity	65
11.5.6	Meas. spot optimization	66
11.5.7	Measurement type	66
11.5.8	Criteria for invalid measurements and their handling	66
11.5.9	Inclination measurement	66
11.5.10	View spectral distribution	66
11.6	Discharge table	66
11.7	W-v relation	67
11.7.1	Usage	67
11.7.2	Learning of the W-v relation	68
11.7.3	Water levels for the W-v relation	68
11.7.4	Activation	68
11.7.5	W-v priority	68
11.7.6	W-v table reset	68
12	Communication	69
12.1	Communication protocols	69
12.2	Data output	69
12.2.1	Main values	69
12.2.2	Special values	70
12.2.3	Analysis values	70
12.2.4	Quality value	71
12.2.5	Exception values	72
12.3	RS-485	72
12.3.1	What is RS-485?	72
12.3.2	What can I do with it?	73
12.3.3	Configuration	73
12.3.4	Data output options	75
12.3.5	Sommer bus protocol (SBP)	75
12.3.6	Standard protocol	79
12.3.7	Sommer old protocol	82
12.3.8	RS-485 commands	82
12.3.9	Sommer CRC-16	84
12.4	SDI-12	86
12.4.1	What is SDI-12?	86
12.4.2	What can I do with it?	86
12.4.3	Configuration	86
12.4.4	Data structure	86
12.4.5	SDI-12 commands	87
12.5	Modbus	91
12.5.1	What is Modbus?	91
12.5.2	What can I do with it?	92
12.5.3	Wiring	92

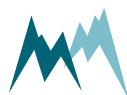

12.5.4	How to switch the SQ-R to Modbus mode	93
12.5.5	Modbus commands and registers	93
12.5.6	How to switch the SQ-R to Sommer bus protocol	96
12.5.7	PLC integration	97
13	Pulse output	98
13.1	What can I do with it?	98
13.2	How to wire pulse output	98
13.3	Configure pulse output	98
13.3.1	Impulse output for discharge volume	98
14	Analog output	101
14.1	What can I do with it?	101
14.2	Activation	101
14.3	Scaling	101
14.3.1	IOUT2 – water level	102
14.3.2	IOUT4 – flow velocity or discharge	103
14.4	Simulate current output	103
15	Parameter definitions	104
A	Measurement trigger	104
B	Measurement Interval	104
C	Level (W)	105
C-A	Mean value, no. of values	105
C-B	Filter, type	106
C-C	Test	106
C-D	Adjustment	106
C-E	W_Q, fixation level	107
C-F	WMA, maximum level	107
C-G	WLL, low level border	107
C-H	WCF, cease to flow level	108
C-I	W-v table reset	108
D	Velocity	108
D-A	Viewing direction	108
D-B	Possible flow directions	109
D-C	River inclination	110
D-D	Yaw angle	110
D-E	Measurement duration	110
D-F	Filter, no. of values	110
D-G	Filter, type	111
E	Discharge table	112
E-A	Status	113
E-B	Level (W)	113
E-C	k value	113

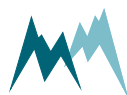

E-D	Area (A)	113
F	DIG OUT	114
F-A	DIG-OUT Function	114
F-B	IO, discharge volume per impulse	114
F-C	IO, impulse width	115
F-D	IO, simulation impulse output	116
F-E	LM, trigger via	118
F-F	LM, limit type	118
F-G	LM, limit value	119
F-H	LM, hysteresis	119
G	Technics	120
G-A	Language/Sprache	120
G-B	Decimal character	120
G-C	SDI-12 address	121
G-D	Channel type	121
G-E	W-v priority	121
G-F	Area correction	122
G-G	Advanced settings	122
	G-G-A Reset general behavior	122
	G-G-B Reset total discharge volume	122
	G-G-C Inclination measurement	123
	G-G-D Sleep mode	123
	G-G-E Sommer ID	124
G-H	Tech. level (W)	124
	G-H-A Supply	124
	G-H-B Warm-up time	125
	G-H-C Measurements per cycle	125
G-I	Tech. velocity (v)	125
	G-I-A Minimum velocity	126
	G-I-B Maximum velocity	126
	G-I-C Meas. spot optimization	126
	G-I-D Measurement type	127
	G-I-E Stop, min. quality (SNR)	128
	G-I-F Stop, max. opp. direction	129
	G-I-G Stop, number of valid meas.	129
	G-I-H Stop, behavior	129
	G-I-I Stop, replace value	130
	G-I-J Stop velocity at WLL	130
	G-I-K Meas. spot weighting	131
G-J	4-20 mA outputs	131
	G-J-A Status	131
	G-J-B IOU2, level 4-20 mA span	132
	G-J-C IOU2, level 4 mA value	132

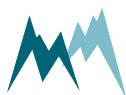

	G-J-D	IOUT4, max. discharge	132
	G-J-E	IOUT4, max. velocity	133
	G-J-F	Simulate current output	133
G-K		RS-485 Protocol	133
	G-K-A	Device number	134
	G-K-B	System key	134
	G-K-C	Measurement output	134
	G-K-D	Information	134
	G-K-E	Wake-up sequence	135
	G-K-F	Prefix holdback	135
	G-K-G	MODBUS, set default	136
	G-K-H	MODBUS, device address	136
G-L		RS-485 Port	136
	G-L-A	Baud rate	136
	G-L-B	Parity, stop bits	137
	G-L-C	Minimum response time	137
	G-L-D	Transmitter warm-up time	138
	G-L-E	Flow control	138
	G-L-F	Sending window	138
	G-L-G	Receiving window	138
G-M		Units and decimals	139
	G-M-A	Level, unit	139
	G-M-B	Level, decimals	139
	G-M-C	Velocity, unit	140
	G-M-D	Velocity decimals	140
	G-M-E	Discharge (Q), unit	140
	G-M-F	Discharge (Q) decimals	141
	G-M-G	Total discharge volume unit*	141
	G-M-H	Total discharge volume decimal	142
	G-M-I	Simulation, discharge volume	142
	G-M-J	Area (A), unit	145
	G-M-K	Area (A) decimals	145
H		Special functions	146
	H-A	View spectral distribution	146
	H-B	Veloc. radar inspection	146
	H-C	Continuous meas. mode (temp).	146
	H-D	View spectral trap	147
	H-E	Set total discharge volume	147
	H-F	View setup	147
	H-G	Device status	147
	H-H	W-v table view	148
	H-I	W-v table reset	148
	H-J	Set factory default	148



H-K	Temp. load factory default	148
H-L	Relaunch program	148
H-M	Replace program	148
Appendix A	Troubleshooting	149
A.1	Devices	149
A.1.1	The SQ-R is not responding or returns unreadable characters	149
A.1.2	The SQ-R reboots repeatedly	151
A.2	Measurement data	151
A.2.1	Measurement data are not updated	151
A.2.2	The SQ-R returns no or zero velocity	152
A.2.3	The SQ-R returns negative velocities	152
1.2.4	The SQ-R returns the wrong water level	153
A.2.5	The SQ-R continuously returns the same water level	153
1.2.6	The SQ-R returns no water discharge	154
A.2.7	The measured discharge is too low or too high	154
A.2.8	The SQ-R returns negative discharge values	155
A.2.9	Learned velocity and discharge are inconsistent	156
1.2.10	Quality values are low or negative	156
1.2.11	Velocity/level data show spikes	156
A.2.12	W-v table reset fails	157
A.3	Firmware & software	157
1.3.1	Registration of SQ-Commander fails	157
A.3.2	Commander loads wrong setup	157
A.3.3	Firmware update via RS-485 is aborted	158
A.4	RS-485	158
A.4.1	Configuration via terminal shows unexpected behavior	158
A.5	SDI-12	158
A.5.1	The SQ-R is not detected by a SDI-12 master device	158
A.6	Analog output	159
A.6.1	The 4-20 mA output is wrong	159
Appendix B	Unwanted reflections	160
B.1	Open channel	160
B.2	Closed channel	161
2.3	Examples of velocity spectra	162
Appendix C	CRC-16 array	166

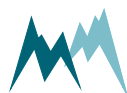

1 What is the SQ-R?

The exact and real time knowledge of water discharge is of central importance for the operation of waste water treatment facilities, cost allocation in sewage networks and management of communal and industrial water resources.

The SQ-R sensor is a continuous measurement device for the contact-free determination of the water discharge of open or closed canals. It combines two sensors in one system. The first determines the water level by measuring the transit time of a radar signal, the second simultaneously measures the flow velocity of the water surface by means of the Doppler frequency shift. Following each measurement, the sensor applies an advanced hydraulic model to compute the mean velocity, which in turn is used to calculate the water discharge.

Due to the contact-free measurement method the SQ-R can be installed on extension arms without costly structural measures in the water or sewage treatment canal. This also has the advantage that the sensor is located outside the danger area of floods and that it requires virtually no maintenance over many years.

Backwater situations caused by inflows, weirs and downstream standing water bodies show no stable relation between water level and discharge. In many situations hysteresis effects with different relations for rising and falling water levels occur. Therefore, the determination of such relations is affected by substantial uncertainty. Only additional information about flow velocity permits the calculation of discharge under these difficult conditions.



FEATURES

- Contact-free radar method prevents soiling and damage
- Automatic discharge calculation based on hydraulic model with multiple k-factors.
- Sensor self check with status and error output.
- AI-based machine learning for compensation of environmental influences and early detection of errors.
- 3-point velocity calibration certificate.
- Advanced velocity diagnostics with spectrum display
- Discharge calculation inside the SQ-R.
- Water level and velocity sensor combined in one weather and vandalism proof housing.



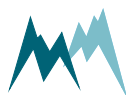

2 Unpacking

When unpacking your SQ-R sensor box please make sure that the following items are present:

Qty	Art	Item
1	-	SQ-R in the required version
1	-	Manual and SQ-Commander Software on USB stick

In case of missing or damaged items please contact your Sommer Messtechnik sales partner.

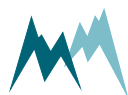

3 Get started

Follow the steps described below to set the basic configurations and to acquire the first measurement results.



NOTE Perform the first start-up in your lab or office before installing the equipment in the field!

3.1 Connect the SQ-R to your PC

1. Install the SQ-Commander support software (see [Installation of SQ-Commander](#))
2. Connect the yellow and gray wires of the sensor cable to the RS-485 to USB converter cable and plug it into your PC as illustrated in the figure below.
3. Connect the RS-232 to USB converter cable to the SQ-R and a USB port on your PC.
4. Connect a 9...28 VDC power supply to the SQ-R.
5. Establish a connection between the SQ-R and the SQ-Commander. See the video [Connect a device](#) in the online [Service center](#).

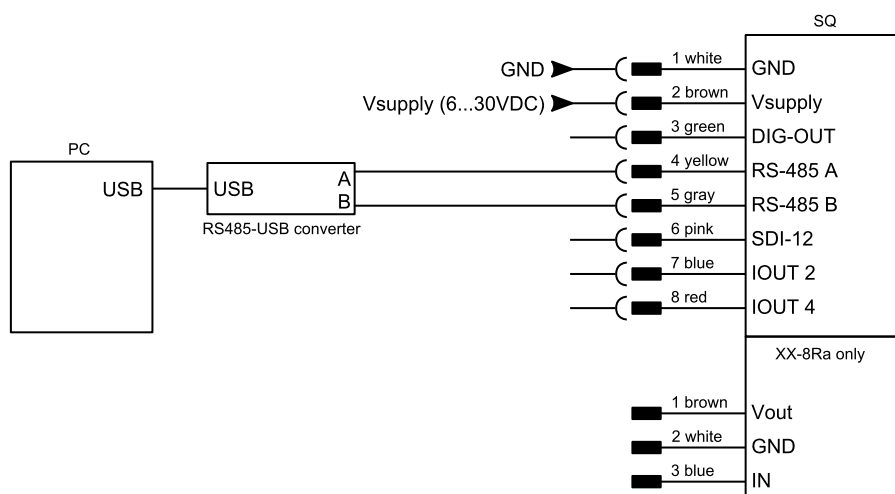

3.2 Configure the SQ-R

1. Select language, decimal character, units and decimal places (see [General settings](#))
2. Select the measurement trigger (see [General settings](#))
3. Set the parameters of the water level measurement (see [Water level measurement](#))
4. Set the parameters of the velocity measurement (see [Velocity measurement](#))
5. Transfer the discharge table from the SQ-Commander to the SQ-R sensor (see [Discharge table](#))

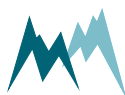

6. Optional: Configure analog outputs (see [Scaling](#))
7. Send any modifications to the SQ-R by clicking [Upload modified parameters to device](#).

3.3 Adjust the SQ-R to the current water level

This step needs to be performed as soon as the SQ-R has been installed at its final location. The respective procedure is described in [Adjustment of water level](#).

3.4 Acquire measurements



ATTENTION Do not start the SQ-R while the target surface is within the blanking distance of the level sensor! Otherwise the SQ-R will not receive level measurements for several minutes! See [Specifications](#) for the blanking distance of your sensor.

1. Establish a connection to your device. See the video [Working with connections](#) in the SQ-Commander section of the online [Service center](#).
2. Record multiple measurements and verify their reliability. See the [View live data of the](#) in the SQ-Commander section of the online [Service center](#).

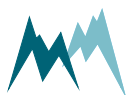

4 How the SQ-R works

4.1 Water level

4.1.1 Definition

The water level W is the vertical distance of a point of the water surface above or below a reference level defined, e.g., by the deepest point of the cross-sectional profile, sea level or gauge zero (GZ).

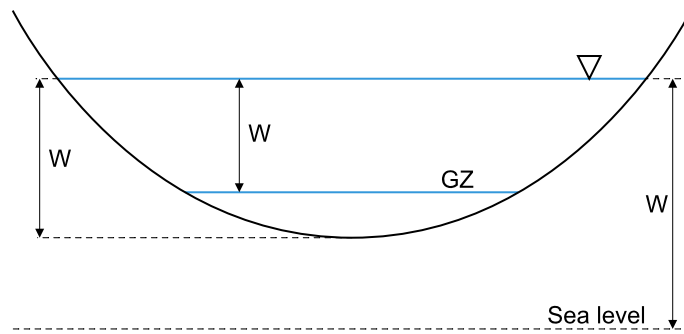

Figure 1 Water level W and gauge zero GZ

4.1.2 Principle of measurement

The water level sensor is installed above a river or channel and transmits a short radar signal towards the water surface. As illustrated in Figure 2 this signal is reflected at the water surface and recorded by the sensor now working as a receiver. The traveling time of the impulse is directly proportional to the distance between the sensor and the water surface.

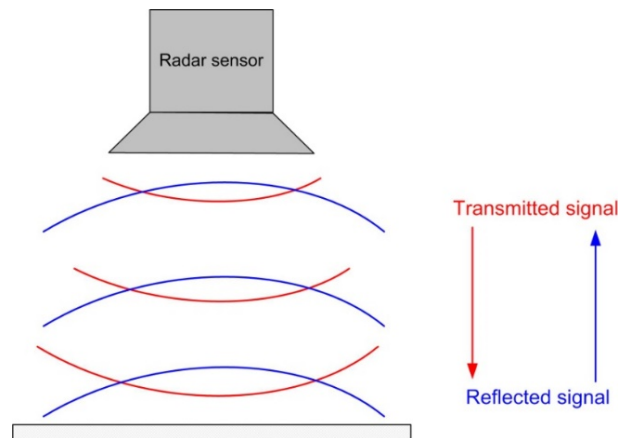

Figure 2 Principle of water level sensor

4.2 Flow velocity

4.2.1 Principle of measurement

The contact-free measurement of the flow velocity is based on the principle of the Doppler Effect. The integrated velocity radar sensor transmits a signal with a constant frequency in a specific angle towards the water surface (see Figure 3). There, the signal is reflected and shifted in frequency due to the movement of the water body. The reflected signal is received by the antenna of the integrated velocity radar sensor. By comparing the emitted frequency to the frequency of the reflected signal from the water surface the local velocity can be determined.

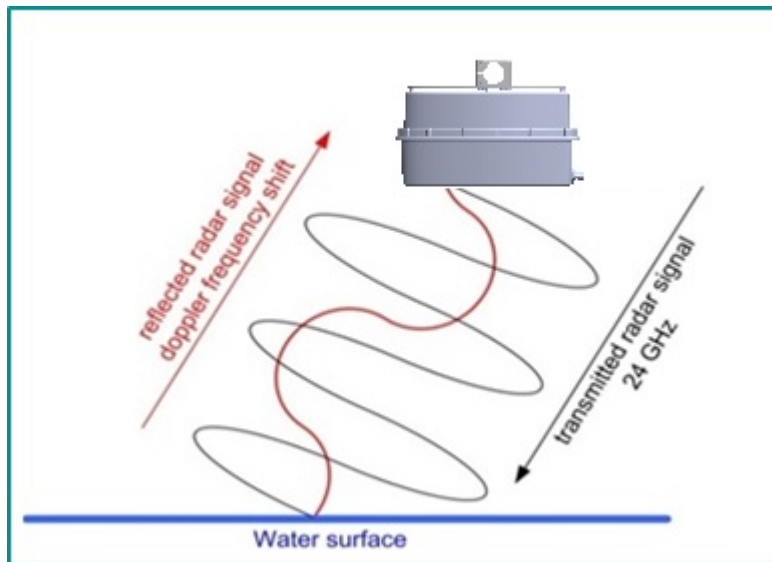

Figure 3 Principle of flow velocity sensor

4.2.2 Flow direction separation

Water can either flow towards or away from the integrated velocity radar sensor. Depending on the flow direction a frequency shift to higher or lower frequencies occurs. This circumstance allows the SQ-R sensor to separate the water movements by their directions and to separately evaluate the corresponding velocity distribution.

4.2.3 Inclination angle measurement

As the SQ-R sensor is directed in a specific angle towards the water surface an angle correction has to be applied. The SQ-R measures its vertical inclination with an internal sensor and applies an automatic angle correction.

4.2.4 Conditions of the water surface

The water surface has to move distinctly and a minimum roughness has to be present to measure a discernible Doppler frequency shift. The more rippled the water surface and the higher the flow velocity is the more reliable the measurements are. The minimum ripple height for a valid analysis is about 2 mm depending on the used frequency. For very slow moving rivers this requirement might not be fulfilled and a continuous and correct velocity measurement cannot be guaranteed.

4.2.5 Radar spectrum

The integrated velocity radar sensor has an opening angle of 12° . Thus, the reflected radar signal of an area is measured. The size of this area depends on the inclination angle and the distance between the sensor and the reflecting water surface.

The velocities appearing in the measured area have a specific distribution depending on the water flow conditions. The velocity distribution is determined with a digital signal processor via spectral analysis, and the dominant velocity in the measurement area is calculated.

As illustrated in [Figure 4](#) the radar spectrum is recorded for water flows up- and downstream. In the lower part of [Figure 4](#) the velocity spectrum of water flowing away from the radar sensor is displayed, in the upper part the spectrum of water flowing towards the sensor. The yellow area is the part of the spectrum used for analysis and the vertical green line indicates the resulting velocity.

By interpreting the radar spectra, velocity measurements can be analyzed in detail. A spectrum can have a narrow or broad peak, one or more maxima or it can identify only one velocity direction. Awareness of this can result in a modification of the settings for the velocity measurement.

For detailed information on how to proceed if more than one peak is visible in the radar spectrum please refer to [Appendix B](#).

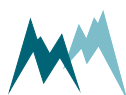

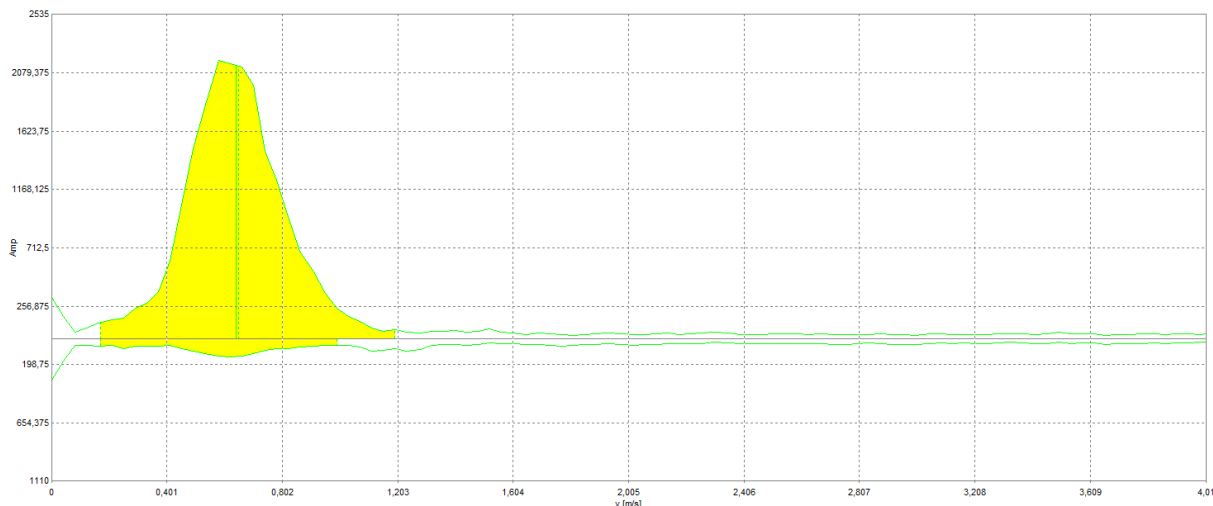

Figure 4 Radar spectrum

4.3 Determination of water discharge

4.3.1 Base equation

The discharge Q is the volume of water V flowing through a cross Section of a river per time unit t . Therefore the dimension is m^3/s , l/s , ft^3/s or m^3/day .

$$Q = \frac{V}{t}$$

By applying the continuity equation the expression above can be transformed into the base equation of the discharge measurement:

$$Q = A \times v_m$$

where A is the wetted cross-Sectional area and v_m the mean flow velocity.

The integrated velocity radar sensor measures the local velocity v_l at the water surface and not the mean velocity v_m . Therefore, a dimensionless correction factor k has to be implemented to calculate the mean velocity from the local velocity:

$$\frac{v_m}{v_l} = k \rightarrow v_m = k \times v_l$$

The k -factor depends on the flow conditions and consequently on the water level W . Its usual range is 60 to 90 % of v_l . In combination with the base equation the discharge is calculated:

$$Q = A(W) \times k(W) \times v_l$$

For the SQ-R a discharge table is generated from the cross-Sectional areas $A(W)$ and the k-factors $k(W)$ for different water levels. This table is stored in the SQ-R sensor and is the basis for the discharge calculation. It is essential that the water levels of the discharge table correspond to the same reference as the water level measurement of the SQ-R sensor.

4.3.2 k-Factors

The k-factors are determined by numerical hydraulic modelling. The k-factors mainly depend on the water level, the shape of the channel/river cross-Section, the turbulence of the flowing water and the mounting position of the SQ-R sensor. By applying a hydraulic model the total water level range can be determined and the discharge calculated from the time of installation. As the k-factors are site-specific they have to be determined for each measurement site.

The PC software SQ-Commander by Sommer Messtechnik can be used to compute k-factors based on hydraulic modelling. Additionally, reference measurements can be used to verify and correct modelled k-factors.

4.3.3 Cross-Sectional area

The cross-Sectional area $A(W)$ as a function of the water level is calculated from the channel/river profile. $A(W)$ values can be computed with the software SQ-Commander by Sommer Messtechnik.

4.3.4 Discharge calculation

The water discharge is calculated from the measured values of W and v_1 using the discharge table stored in the SQ-R sensor. The following scheme illustrates this procedure:

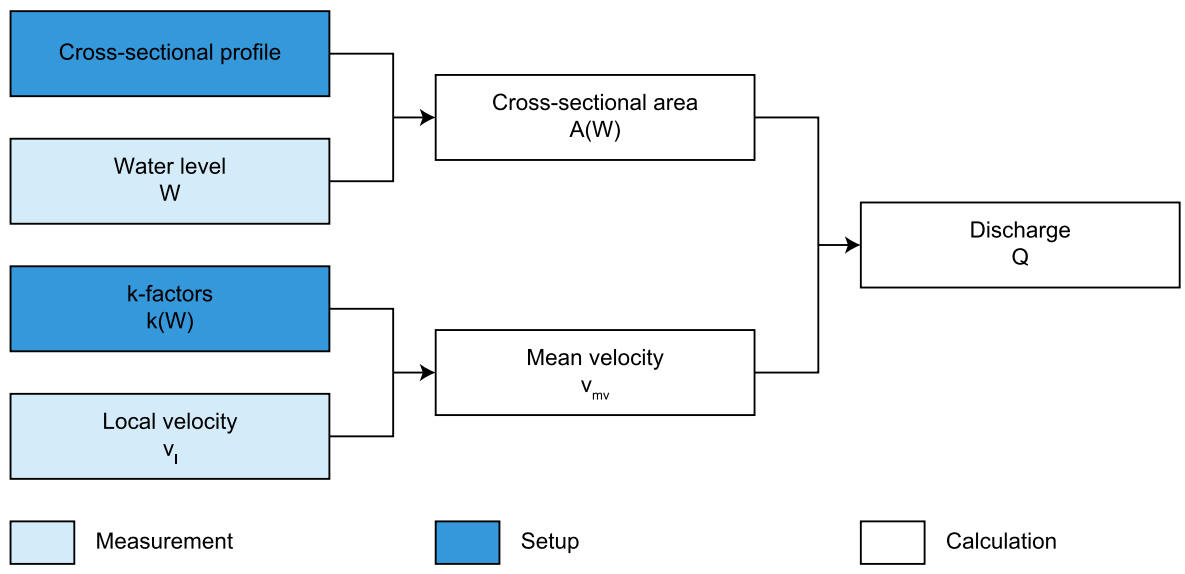
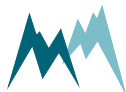

Figure 5 Discharge calculation scheme



5 Components

5.1 Velocity sensor

The velocity sensor of the SQ-R uses a frequency of 24.160 GHz at an output power of 26 dBm.

5.2 Level sensor

The SQ-R contains a radar level sensor that operates at a frequency of 80 GHz.

5.3 Main connector

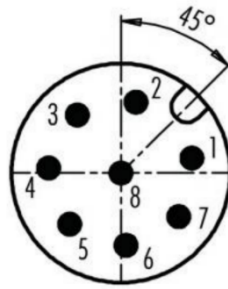
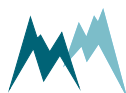

Figure 6 Pin configuration of connector MAIN

	Pin	Function	Description
Power supply	1	GND	Ground
	2	Vsupply	9...28 VDC
Digital switching output	3	DIG-OUT	Max. 1.5 A
RS-485 interface	4	RS485 A ¹	1 x RS-485 (1200...115200 Baud)
	5	RS485 B ¹	

¹According to TI notation which differs from the standard EIA notation



	Pin	Function	Description
SDI-12 interface	6	SDI-12	1 x SDI-12 (1200 Baud)
Analog outputs	7	IOUT2	Water level (4...20 mA)
	8	IOUT4	Discharge (4...20 mA)

Configuration of connector MAIN

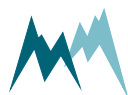

6 Specifications

Physical and environmental	
Power supply	9...28 VDC; Reverse voltage protection, overvoltage protection
Power consumption at 12 VDC	1.5 Ah per day Peak current drain 91 mA Inrush current <200 mA (for a measurement interval of 60 s)
Outputs	RS-485 ASCII / Modbus RTU SDI-12 Analog output 4...20 mA (14 bit, max. load 250 Ω) Digital output (low: 0V, high: Vsupply, max. 1.5 A)
Operating temperature	-40...60 °C (-40...140 °F)
Storage temperature	-40...60 °C (-40...140 °F)
Relative humidity	0...100 %
Protection rating	IP 68
Lightning protection	Integrated protection against indirect lightning with a discharge capacity of 0,6 kW Ppp
Housing material	Zytel 103HSL NC010, resistant to aggressive substances typically found in sewage channels
Mounting bracket	Mounting cube Ø30 mm
Size L x W x H	272 x 152.2 x 185.5 mm (10.71 x 5.99 x 7.30 in), including mounting cube
Weight	1.55 kg (3.42 lb)

Velocity	
Detectable measurement range	0.08...16 m/s (depending on waves)
Accuracy	± 0.01 m/s (certified by METAS)
Resolution	1 mm/s
Direction recognition	+/-
Measurement duration	5...240 s

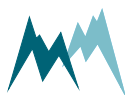

Measurement interval	8 s...5 h
Measurement frequency	24 GHz (K-Band)
Radar opening angle	12°
Distance to water surface	0.05...35 m (0.16...114.83 ft)
Vertical inclination	Measured internally

Automatic vertical angle compensation

Accuracy	$\pm 1^\circ$
Resolution	$\pm 0.1^\circ$

Water level

Measurement range (distance between level sensor and water surface)	0.05...8 m (0.16...26.25 ft)
Accuracy	≤ 2 mm
W-band (80 GHz technology)	W-band (80 GHz)
Opening angle	8°

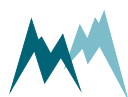

7 Installation

7.1 Site selection

The selection of a suitable measurement site for the SQ-R is crucial for the reliability and accuracy of the measurement results. Several aspects related to the hydraulic situation and the mounting of the sensor have to be considered.

7.1.1 Hydraulic requirements

Cross-Sectional velocity distribution

In general, the cross-Sectional velocity distribution at the measurement site must not be changed. For example, fluctuating inflows and regulated weirs can influence the measurements. Therefore a minimum distance to such influences of 5...10x the channel width up- and downstream of the measurement site is recommended. The following drawings illustrate some examples:

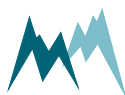
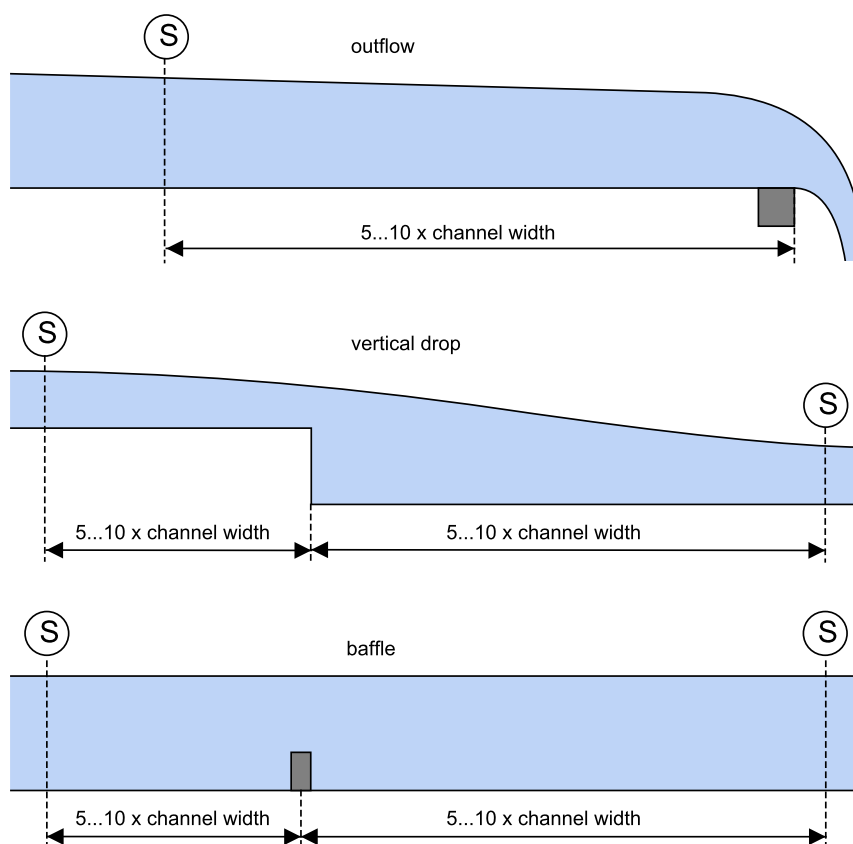

Stationary waves

There must be no stationary waves present in the field of view of the SQ-R as they can negatively influence the measurement accuracy. Stationary waves may be caused by big stones and other obstacles; their impact depending on water level. Stationary waves cause errors in angle as the radar impulse is partly reflected from them and not the plane water surface. Also, they may overestimate the water level.

Range with unchanging cross Section

The cross-Section of the channel/river in the vicinity of the flow measurement needs to be stable. Pillars of bridges and bends or corners in the flow channel represent changes of the cross-Section. The minimum distance with a constant cross-Section upstream and downstream of the sensor should be 5...10x the channel width.

Stable cross-Section

The calculation of the discharge requires the cross-Sectional area of the channel/river (see [Determination of water discharge](#)). Therefore, the cross Section of the river must not change as this causes the need of a new site calibration. Examples of a changing cross-Section are erosion of the channel bed, deposition of debris or the relocation of sediments. Changes of the cross-Section may be identified by changes in the W-v relation.

Adequate wave movements

Waves or ripples with a height of at least 2 mm have to be present at the water surface over the full expected water level range. Especially very slow flowing rivers often do not meet this requirement (see also [Conditions of the water surface](#)).

Influence of wind

For slow moving, deep rivers the flow velocity measurement may be interfered by waves which are caused by wind. If such an influence is observed, the measurement site should be shielded from wind by proper means or an alternative site should be considered.



7.1.2 Installation requirements

Viewing direction

It is recommended to install the SQ-R with its tip pointing upstream. This has some essential advantages: For installations on bridges the influence of pillars on the water flow conditions are avoided. Additionally, the influence of precipitation is eliminated by a direction separation obtained from the velocity spectrum (see [Flow direction separation](#)).

Free field of view

The SQ-R sensor interprets all movements in its field of view. Therefore, no moving objects shall be present in the field of view of the SQ-R. [Figure 8](#) shows the size of the measurement spot and its distance from the SQ-R sensor for different installation heights. Consider these dimensions when installing the sensor.

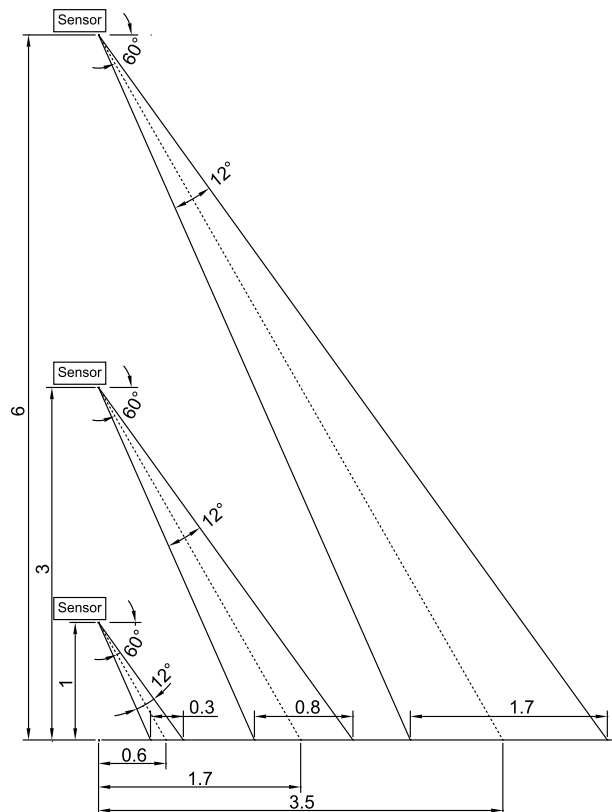

Figure 8 Measurement spot size for different mounting heights (dimensions in m)

Installation underneath bridges

When the SQ-R is installed underneath a bridge it has to be assured that no rain or melt water is dripping through the field of view of the velocity radar. The occurrence of such events may influence the measurement considerably.

Installation on extension arms

The SQ-R sensor can be mounted on an extension arm protruding from a river bank or channel wall. Sommer Messtechnik suggests installing a rotatable extension arm to facilitate maintenance.

Installation above open channels or rivers

The SQ-R can be mounted in a range between 0.25 to 6 m above the water surface. With the radar version this range can be extended to 0.05... 8 m above the water surface.

When the SQ-R is installed in an open channel or above a natural river it has to be assured that no rain or melt water from any structure above the sensor is dripping through the field of view of the velocity radar. The occurrence of such events may influence the measurement considerably.

Installation above half-pipes

The SQ-R can be used to determine the flow in small half-pipes as they are common in sewage networks. Due to the curved channel surface and the flow structure encountered, the minimum diameter of such a pipe is limited to about 150 mm.



ATTENTION

When installing the SQ-R above a half-pipe follow the rules listed below:

- The SQ-R must not be mounted too close to any covered sections of the pipe. The closer it is mounted to covered sections, the more reflections may occur.
- The SQ-R must be mounted parallel to the water surface.
- The distance between the bottom of the pipe and the sensor should be the max. water level plus 250 ... 300 mm (see [Figure 9](#)).
- The space between the SQ-R and the water surface must be free of any obstacles. Any surface reflects the sensor signal and may cause interference.



- The level adjustment must be done at high water levels. In this way the SQ-R receives less reflections of the curved pipe surface.

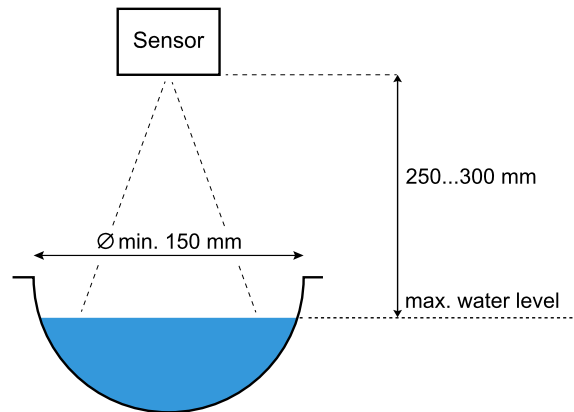

Figure 9 Installation of the SQ-R above half-pipes

Installation in closed channels

In closed water channels such as discharge pipes multiple reflections of the sensor signal may occur. In a situation as illustrated in [Figure 10](#) the radar signal is not only reflected at the water surface, but also on the channel wall. This may influence the measurement results. Multiple reflections are minimized by a smooth channel surface and channel designs without rectangular edges. For more information on how to proceed if such an installation cannot be avoided please refer to [Appendix B](#).

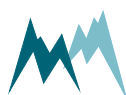



Figure 10 Installation of a SQ-R sensor in a water discharge channel

7.1.3 Documentation

It is recommended to document the measurement site with pictures for future analysis. These may include:

- Measurement site with the installed sensor
- River or channel facing upstream and downstream
- Flow conditions at the measurement site
- Roughness of the river bed or channel walls

7.2 Performing a site survey

Every measurement site requires an individual survey to determine the local hydraulic boundary conditions. These conditions are aggregated the a discharge table, which is used to calculate the discharge based on the measured water level and flow velocity.

Follow the instructions below to perform a complete site survey:

1. Select the reference coordinate system

The measurements of the water level, the mounting position of the SQ-R sensor and points in the cross-sectional profile have to relate to each other. Especially the water levels defined in the discharge table and the water levels measured with the SQ-R sensor have to be consistent. See [Map the cross-sectional profile](#) for the available options.

When selecting the reference system for the measurement site, existing installations for water level measurements should be considered.

Sites with an existing water level measurement

If a water level measurement is already present at the measurement site, i.e. gauge plate or gauge sensor, it is recommended to use the gauge zero (GZ) of the existing measurement as the reference level. This level is usually unique and defined permanently. Moreover, consistency in the existing water level measurement and the SQ-R measurement simplifies interpretation. As illustrated in [Figure 11](#) the level of the gauge zero has to be known in the reference system.

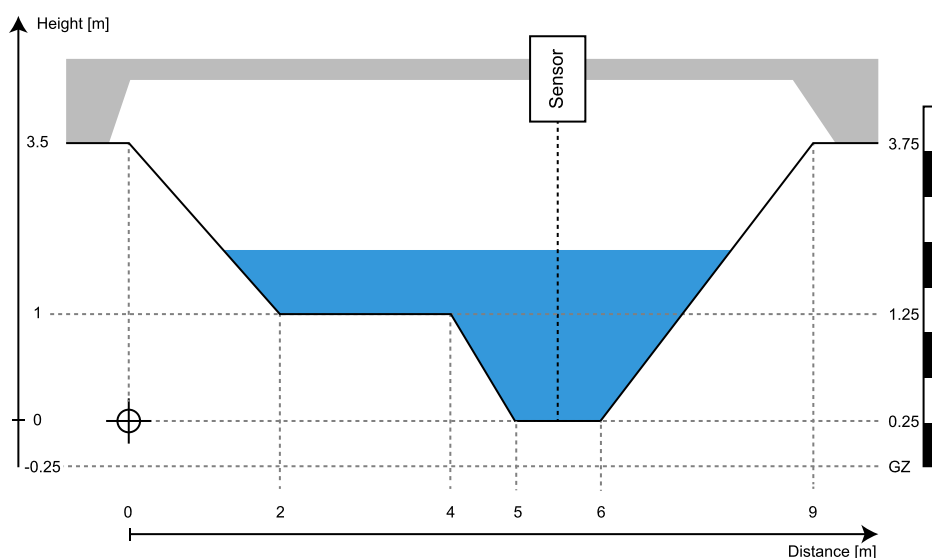

Figure 11 Gauge zero (GZ) of a gauge plate in reference to a channel profile

In the example shown in [Figure 11](#) gauge zero is at -0.25 m in the reference coordinate system of the cross-Section H.

Sites without an existing water level measurement

For measurement sites without an existing water level measurement a new reference has to be defined. It is recommended to select a stable, fixed point as reference for future verification. It is essential to exactly document this point and its relation to the water level W.

For channels with a stable lining a point on the surface can be selected as a reference and gauge zero simultaneously. Thus, the water level can be determined easily and the adjustment procedure for the water level measurement of the SQ-R sensor is simple.

For all other situations a fixed point has to be selected. Examples are survey points or stable, accessible points on bridges or other structures. This reference point has to be mapped in the coordinates of the cross-Sectional profile. The point does not need to be defined as gauge zero, but needs to relate to it.

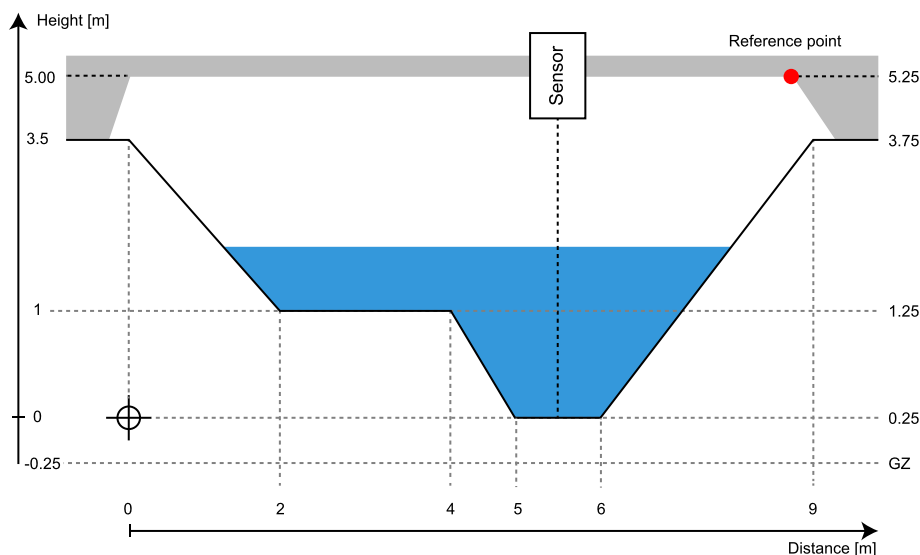

Figure 12 Gauge zero (GZ) with a fixed point referenced to it

In the example of Figure 12 a fixed point was defined on a bridge. The height of the point is 5 m in the reference coordinate system of the cross-Section H. The gauge zero was defined as -0.25 m. Thus, the fixed point is at 5.25 m in the coordinate system of the water level measurement W.

2. Map the cross-sectional profile

The cross-Sectional profile represents a vertical cut through the channel from the river bed to the maximum expected water level. It is required for the calculation of the wetted cross-Sectional areas $A(W)$ and the modeling of the k-factors $k(W)$ (see [Determination of water discharge](#)).

The cross-Section is usually taken at the position of the water level measurement. A point in the profile is specified in one of the following coordinates:

- height relative to bottom with positive values upwards, see [Figure 13](#)
- absolute height above sea level, see [Figure 14](#)
- height relative to top with positive values downwards, see [Figure 15](#)

3. Determine the roughness of the riverbed

An estimation of the roughness on the edges of the cross-Sectional profile is necessary to model the k-factors. The roughness is specified as absolute roughness k_s , Strickler coefficient k_{St} or Manning co-efficient n . In the SQ-Commander software the roughness is specified in categories, e.g. "Sand bed" or "Brickstone walls".

4. Locate the position of the SQ-R

The exact position of the SQ-R in the reference system has to be known (see [Figure 16](#)). This information is essential for modelling the k-factors and adjusting the water level measurement.

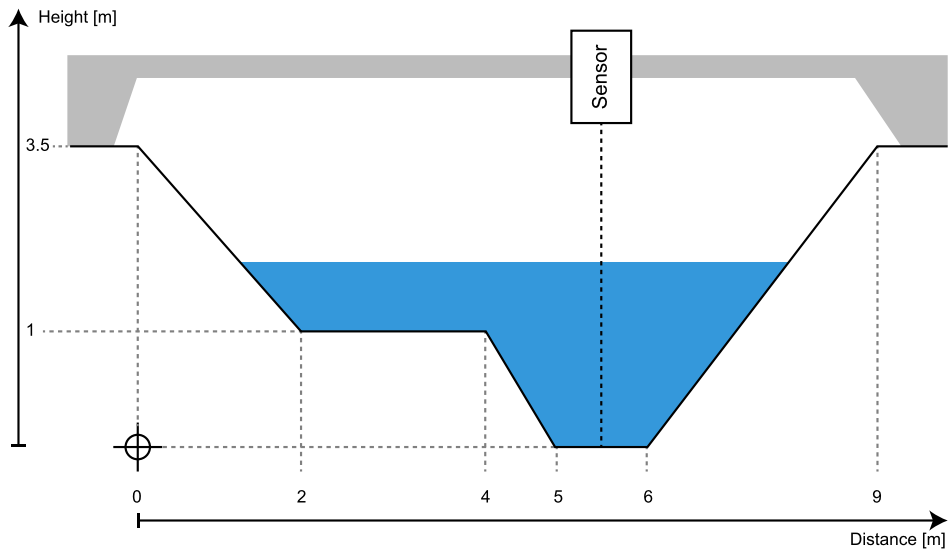

Figure 13 Cross-Sectional profile with height relative to bottom

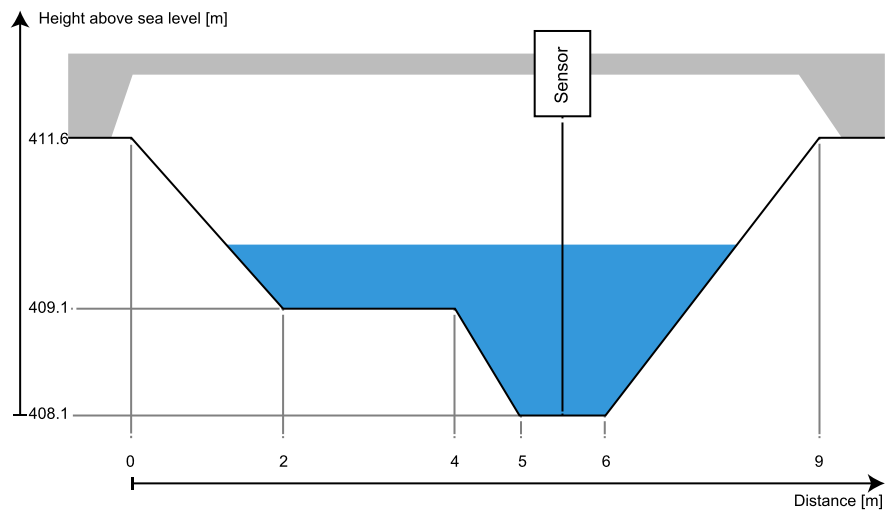
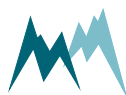

Figure 14 Cross-Sectional profile with absolute heights



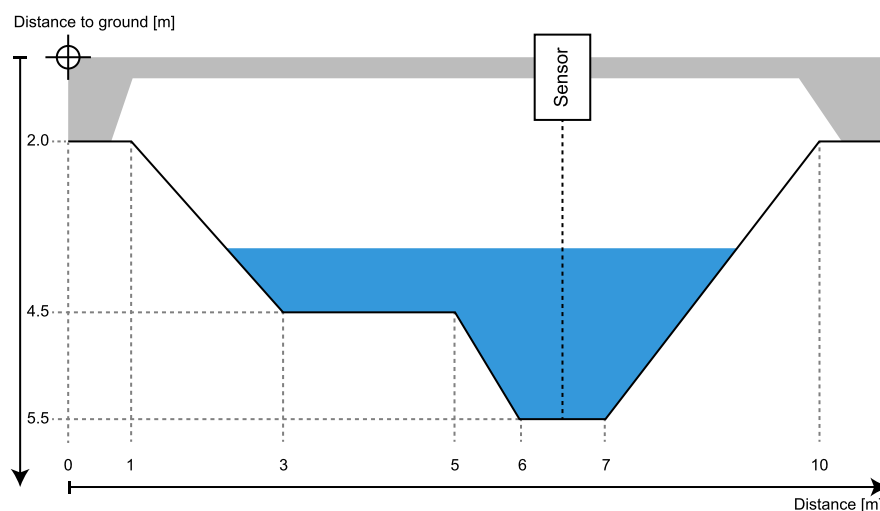

Figure 15 Cross-Sectional profile with heights relative to top

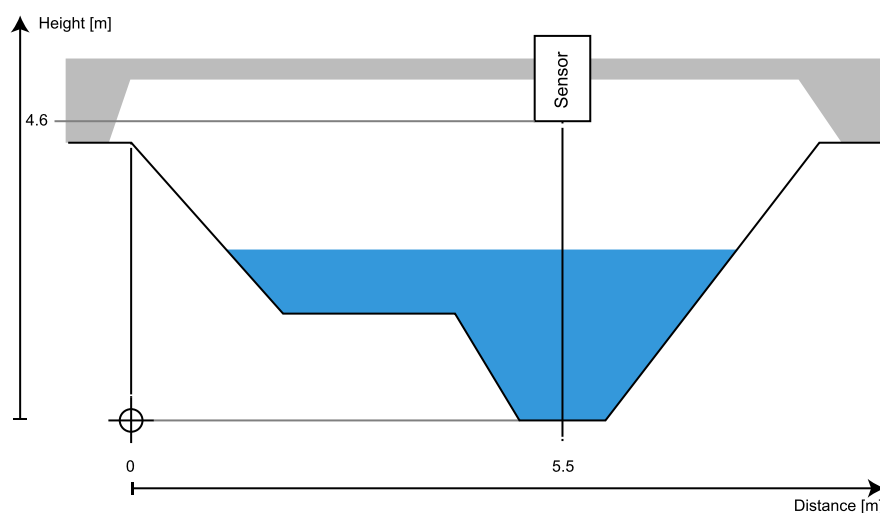

Figure 16 Cross-Sectional profile with SQ-R position relative to bottom

5. Build the discharge table

The survey of the measurement site is expressed in the form of a discharge table as shown in [Table 1](#). This table is stored in the SQ-R sensor and is the basis for the calculation of the discharge as described in [Discharge calculation](#).

The discharge table contains the cross-Sectional areas $A(W)$ and k -factors $k(W)$ of different water levels W . The areas $A(W)$ are derived from the cross-Sectional profile, k -factors $k(W)$ are determined according to [k-Factors](#).

The discharge table can contain up to 16 entries which are ordered from low to high water levels. $A(W)$ and $k(W)$ values are interpolated linearly to measured water levels.

The discharge table can be created with the software SQ-Commander by Sommer Messtechnik. After entering the cross- Sectional profile, the channel/river roughness and the sensor position the discharge table is calculated automatically. This table can then be transferred to the SQ-R sensor.

	Status	Level (W)	K value	Area (A)
		[m]	[]	[m ²]
01	on	0.4	64.0	4.7
02	on	0.6	68.7	9.5
03	on	0.8	72.1	14.4
04 ... 14
15	on	4.9	79.5	141.8
16	on	6.7	80.7	202.4

Table 1 Example of a discharge table

7.3 Things to consider for installation

7.3.1 Power supply

The SQ-R is designed for extreme environmental conditions at remote sites and with no grid connection. The sensor switches automatically into standby-mode between measurements and thus consumes only 1.5 Ah (1 measurement/minute) per day which can be supplied by a 12V-solar-generator mounted to the mast.

7.3.2 Signal cables

Maximum cable length

Please consider the maximum cable lengths for the applied transmission protocol:

Protocol	Max. cable length
SDI-12	~60 m (depending on wire cross section and number of sensors)
RS-485	~300 m

Table 2 Maximum cable lengths



NOTE Cable lengths longer than 60 m require a heavier gauge wire if the power supply drops below 11 V.

7.3.3 Lightning protection

If the underground at the measurement site permits sufficient current dissipation it is strongly recommended to equip the sensor support or mast with properly dimensioned lightning protection. Consult an expert for advice.

The SQ-R is protected against overvoltage. If a data logger is mounted to the mast, its ground lug must be properly connected to earth ground.

7.4 Required tools and equipment

Prepare the following tools and equipment to install the SQ-R:

Qty	Tool
1	Mounting tube $\varnothing 34...48$ mm
1	Flat spanner 8 mm
1	Cable ties
1	Wire cutter

7.5 Mounting



ATTENTION

The SQ-R must be installed parallel to the water surface! The angle between the water surface and the device must not exceed $\pm 2.5^\circ$.

As illustrated in [Figure 17](#) the SQ-R must be installed parallel to the water surface in both directions: along and perpendicular to the water flow. Additionally, the sloping angle has to be entered in the

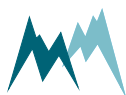

parameter **River inclination**. The sloping angle is always entered as a positive value, irrespective of the viewing direction of the sensor.

In tidal situations where both flow directions occur, the SQ-R should always be mounted horizontally and **River inclination** should be set to **0**.

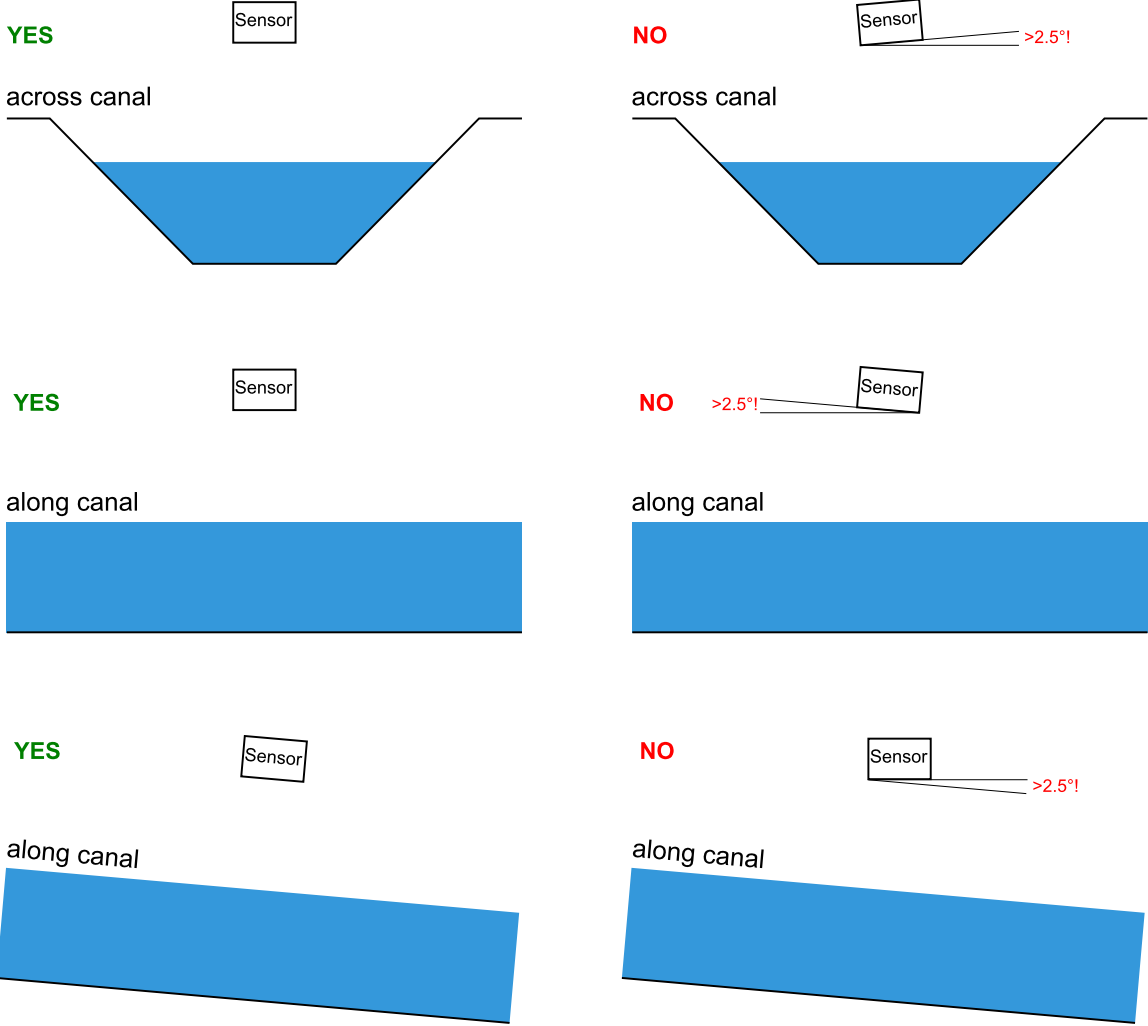
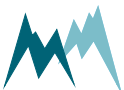

Figure 17 Parallel sensor installation

7.5.1 How do I install the SQ-R in a manhole?

Sommer Messtechnik offers a versatile mounting accessory suitable for circular manholes which allows for easy and quick installations. With this accessory the SQ-R mounting position can be adjusted horizontally and vertically. The accessory is suitable for a manhole diameter of 580...690 mm and is provided with an adjustable mounting pole of 0.5...2.5 m length.





7.6 Wiring

7.6.1 RS-485 wiring

Connect the SQ-R to a data logger or RS-485 network according to the figure below.

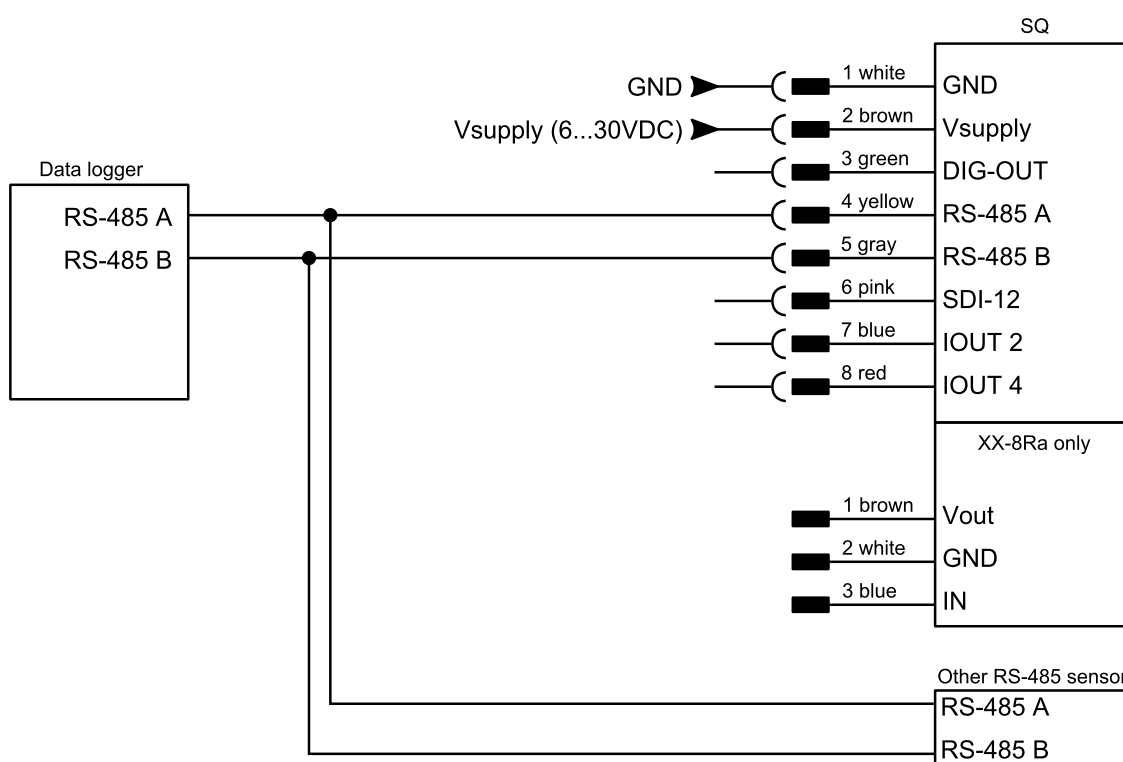

7.6.2 SDI-12 wiring

Connect the SQ-R to a data logger by SDI-12 according to the figure below.

SDI-12 uses a shared bus with a ground wire, a data wire (indicated as SDI-12) and an optional +12 V wire.



NOTE The connection with the 12 V power supply is optional and depends on the connected SDI-12 master device (typically a data logger).

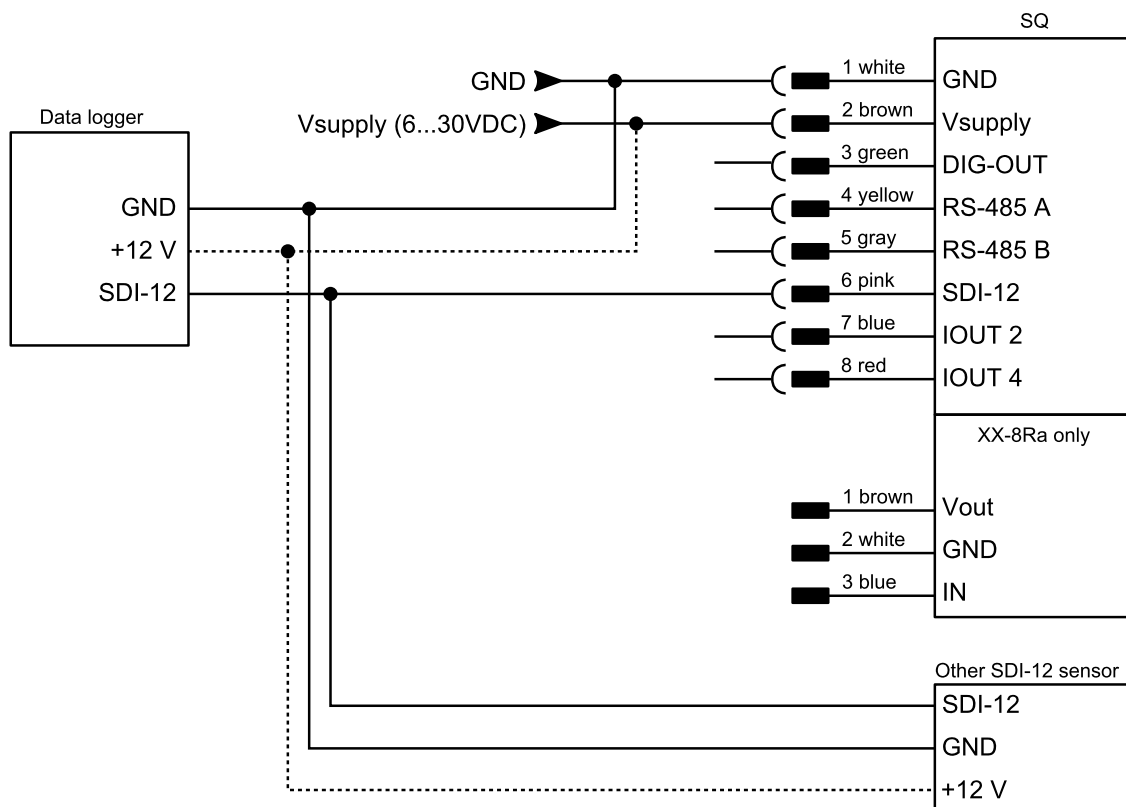
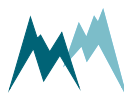
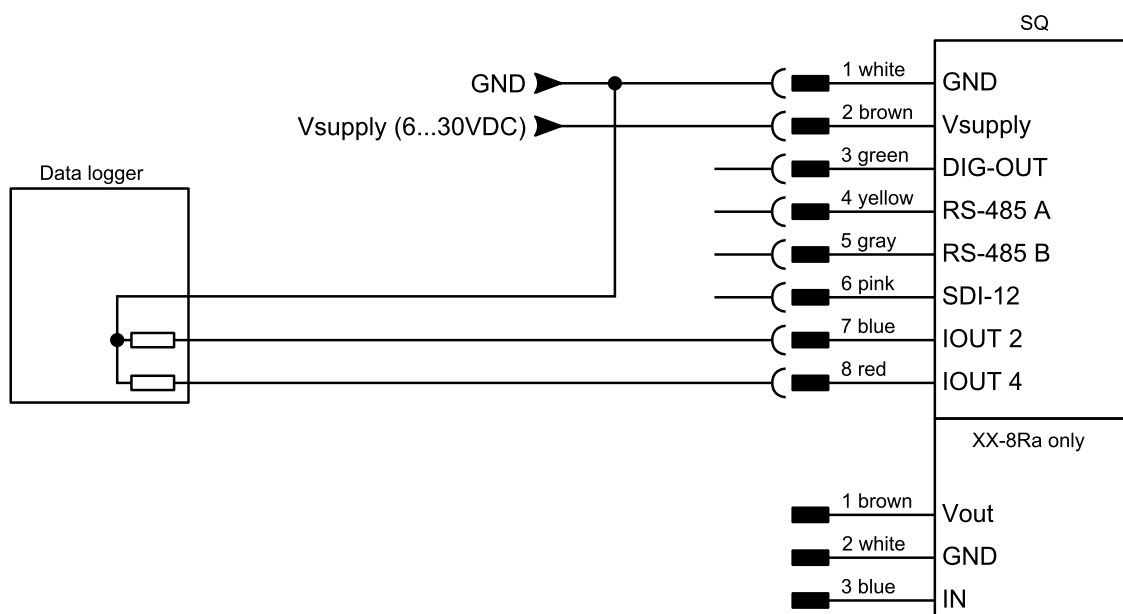

Figure 18 Wiring of the SQ-R with a data logger via SDI-12

7.6.3 How to wire analog outputs

Connect the analog outputs of the SQ-R to a data acquisition device according to the figure below.





NOTE If a data logger is connected to the IOUT outputs, the resistance of the logger input(s) must not exceed 470 Ω .

7.7 Adjustment of water level

Once the SQ-R has been installed at its final location, and has been configured completely, the water level measurement has to be adjusted to the present water level.

Follow the steps below to perform the water level adjustment:

1. Test the water level measurement by clicking [Test](#) in the parameter menu [Level \(W\)](#) of the SQ-Commander.
2. If the displayed water level does not match the manually measured level click [Adjustment](#) in the parameter menu [Level \(W\)](#).
3. Verify the measured water level by applying the [Test](#) function again.

7.8 Start-up

After successful testing, verify that the measurement data are recorded by your data acquisition system and check the data transmission to the remote server if applicable.

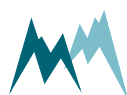

8 Operation

8.1 Connect device to PC

1. Install the SQ-Commander support software (see [Installation of SQ-Commander](#))
2. Connect the yellow and gray wires of the sensor cable to the RS-485 to USB converter cable and plug it into your PC as illustrated in the figure below.
3. Connect the RS-232 to USB converter cable to the SQ-R and a USB port on your PC.
4. Connect a 9...28 VDC power supply to the SQ-R.
5. Establish a connection between the SQ-R and the SQ-Commander. See the video [Connect a device](#) in the online [Service center](#).

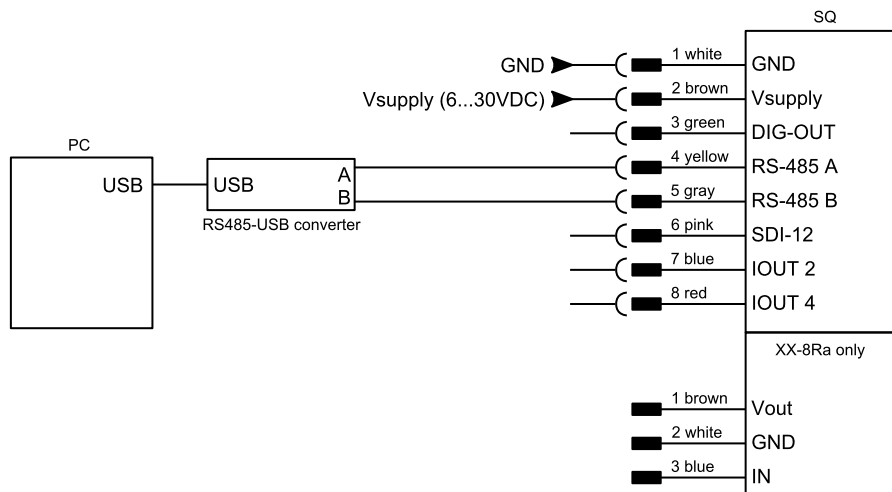

9 Maintenance

The SQ-R generally does not require any special maintenance. However, the device should be inspected occasionally for damage and a dirty sensor surface. To remove dirt use a wet cloth with little force. Do not use any abrasive detergent or scraping tool!

9.1 Device status

During operation the SQ-R continuously performs a self-check to identify any abnormal system behavior or device failure. This self-check is returned by the SQ-R as a code (SFCH-code) with a value of 1 to 16. In the table below the SFCH-code together with their cause and solution. An icon as specified in the legend below is linked to each SFCH-code to indicate the significance of a detected abnormality.

To view the self-check message open the SQ-Commander, connect to the SQ-R and open the tab **Measurements (F3)**. In the main window a section named **Self-check** opens and displays the current device status.

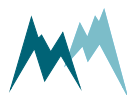



Symbol	SFCH-Code	Description	Cause	Solution
	16	Sensor returns 999997, i.e., level can not be measured or measurement value has not been returned.	<ul style="list-style-type: none">● Sensor connected incorrectly.● Sensor has just been powered.● Sensor is malfunctioning.	<ol style="list-style-type: none">1. Check correct sensor installation (facing water surface).2. Check wire connections.3. Wait until the sensor has acquired its first measurements.4. Re-power the sensor and start Spectrum mode to trigger measurements.



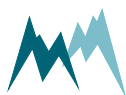



Symbol	SFCH-Code	Description	Cause	Solution
 	15	Sensor Inclination angle is outside the range $\pm 2.5^\circ$ (only applicable if Inclination measurement is set to <i>every measurement</i>).	<ul style="list-style-type: none"> • Sensor mounted improperly. • River inclination set inadequately. • Calibration of inclination sensor incorrect. 	<ol style="list-style-type: none"> 1. Verify that the sensor is installed parallel to the water surface (level measurement is perpendicular to water surface). This also applies to sloping rivers. 2. If sensor is installed with an inclination, verify that River inclination and Viewing direction are correct. 3. Check if the velocity sensor sits firmly in its housing and that the housing is not crooked. 4. Make sure the sensor is not swinging, wobbling or heavily vibrating. Reinforce any brackets if required. 5. In the setting Information of sub-menu RS-485 Protocol, select & Analysis values. This will add the inclination angle to the data output. Check if the displayed angle is plausible and that it changes accordingly if you tilt the sensor. 6. Contact Sommer Messtechnik to recalibrate or replace the inclination sensor.



Symbol	SFCH-Code	Description	Cause	Solution
 	14	Velocity too high for correct determination.	<ul style="list-style-type: none"> • Sensor may be mounted improperly or velocity settings are configured incorrectly. 	<ol style="list-style-type: none"> 1. Check/adjust sensor position 2. Check/adapt settings in menus Velocity and Tech. velocity (v).
	13	Velocity too low for correct determination.	<ul style="list-style-type: none"> • Water flows very slowly and/or river has high waves. This may lead to overlapping velocity peaks. 	<ol style="list-style-type: none"> 1. Rivers with high waves should flow reasonably fast; change measurement site if this is not the case. 2. If waves are small, reduce Minimum velocity und reduce the range between Minimum velocity and Maximum velocity. 3. Check opposite direction content and increase Stop, max. opp. direction. 4. Change the distance to the water surface. 5. Mount the sensor in the reverse direction 6. Create artificial surface waves. 7. If error persists, change measurement spot to one with higher flow velocities.





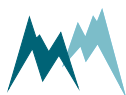

Symbol	SFCH-Code	Description	Cause	Solution
	12	Only applicable to RQ-30L.	<ul style="list-style-type: none"> Level sensor may be configured incorrectly, e.g., sign of water level range may be inverted. 	1. Check/adapt settings of water level sensor.
	11	Not specified	-	-
	10	Velocity indicates wrong flow direction.	<ul style="list-style-type: none"> Sensor may not be properly configured. Insufficient waves on the water surface. Strong winds. 	<ol style="list-style-type: none"> Check parameter Viewing direction. Mount the sensor in the reverse direction
 	9	Velocity cannot be determined.	<ul style="list-style-type: none"> Flow conditions may be outside the range of detection. Sensor may be configured incorrectly or is malfunctioning. 	<ol style="list-style-type: none"> Check/adapt settings in menu Velocity. Check opposite direction content and increase Stop, max. opp. direction. Change the distance to the water surface. Mount the sensor in the reverse direction Create artificial surface waves. If error persists, change measurement site.

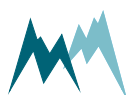





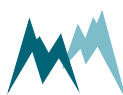

Symbol	SFCH-Code	Description	Cause	Solution
 	8	Opposite direction content is too high.	<ul style="list-style-type: none"> ● Sensor may not be properly configured or is malfunctioning. 	<ol style="list-style-type: none"> 1. Check/adapt settings in menus Velocity. 2. Check opposite direction content and increase Stop, max. opp. direction. 3. Change the distance to the water surface. 4. Mount the sensor in the reverse direction 5. Create artificial surface waves. 6. If error persists, change measurement site.
 	7	Quality (SNR) is too low	<ul style="list-style-type: none"> ● Sensor may not be properly configured or is malfunctioning. ● Insufficient waves on the water surface. 	<ol style="list-style-type: none"> 1. Check/adapt settings in menus Velocity. 2. Check opposite direction content and increase Stop, max. opp. direction. 3. Change the distance to the water surface. 4. Mount the sensor in the reverse direction 5. Create artificial surface waves. 6. If error persists, change measurement site.





Symbol	SFCH-Code	Description	Cause	Solution
 	6	No discharge values	<ul style="list-style-type: none"> ● Sensor cannot determine the cross-sectional area 	<ol style="list-style-type: none"> 1. Check/adapt settings in menu Level (W) and perform a level adjustment. 2. Verify that the profile is correct and check if the water level is within the range of the profile. 3. Verify that the sensor returns velocity values.
 	5	Sensor did not measure flow velocity.	<ul style="list-style-type: none"> ● Water level below WLL, low level border ● Insufficient waves on the water surface. ● Water level has not been adjusted ● WLL, low level border is set too high. 	<ol style="list-style-type: none"> 1. Check/adapt settings in menus Velocity 2. Check Quality (SNR) and opposite direction content and increase Stop, max. opp. direction. 3. Change the distance to the water surface. 4. Mount the sensor in the reverse direction 5. Create artificial surface waves. 6. If error persists, change measurement site.



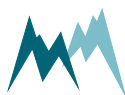



Symbol	SFCH-Code	Description	Cause	Solution
 	4	Water level is above WMA, maximum level	<ul style="list-style-type: none"> • May occur if W-v learning has been optimized for low water levels (high water levels are extrapolated). • Water level adjustment has not been performed. • Sensor has been improperly positioned. • An obstacle may protrude into the field of view of the sensor. 	<ol style="list-style-type: none"> 1. OK if acceptable. 2. Check/adapt settings in menu Level (W) and perform a level adjustment. 3. Verify that the profile is correct and match it to the water level settings. 4. Check that the field of view is free of any obstacles.
 	3	Water level is below WCF, cease to flow level.	<ul style="list-style-type: none"> • May occur during low water levels. • Water level adjustment has not been performed. • Sensor has been improperly positioned. • An obstacle may protrude into the field of view of the sensor. 	<ol style="list-style-type: none"> 1. OK if WCF value >0 is required. 2. Set WCF to 0. 3. Check/adapt settings in menu Level (W) and perform a level adjustment. 4. Verify that the profile is correct and match it to the water level settings. 5. Check that the field of view is free of any obstacles.
 	2	Values of WCF, cease to flow level, WLL, low level border and WMA, maximum level are equal.	<ul style="list-style-type: none"> • Wrong operator input. 	<ol style="list-style-type: none"> 1. OK if acceptable. 2. Check/adapt settings in menu Level (W) 3. Set the values of WCF, cease to flow level, WLL, low level border and WMA, maximum level correctly. WMA > WLL > WCF



Symbol	SFCH-Code	Description	Cause	Solution
	1	No discharge table available.	<ul style="list-style-type: none"> Discharge table has not been uploaded. Discharge table has only one entry. 	<ol style="list-style-type: none"> Upload discharge table. Check entries of discharge table.
	0	Sensor operates normally	-	-

Device status codes

Symbol	Status
	Device failure
	Function check
	Out of range
	Normal operation with optimized setup
	Normal operation

Device status symbols

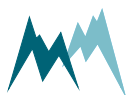

10 Support software SQ-Commander

10.1 Software features

The SQ-Commander is a multipurpose software tool to configure and operate any Sommer Mess-technik device. It offers the following functions:



FEATURES

- Create or import a cross-sectional profile
- Communicate with your SQ-R locally and remotely
- Configure and update the sensor settings
- View your measurement data
- Validate your data with the velocity diagnostics tool
- Transfer data files to HTTP and FTP servers
- Install the SQ-R with easy step-by-step guidance

10.2 System requirements

The SQ-Commander software supports 32- and 64-bit versions of Windows 7 SP1, Windows 8, Windows 8.1, Windows 10 and Windows 11.

For correct operation Microsoft® .NET Framework 4.5 or later must be installed.

10.3 Installation of SQ-Commander

Follow the steps below to install the SQ-Commander software:

1. Plug the USB stick shipped with the device into your PC.
2. Double-click the `commander.msi` installer file on the USB drive.
3. Click **Next** on the pop-up window

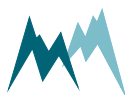



4. Read the instructions and click **Next**

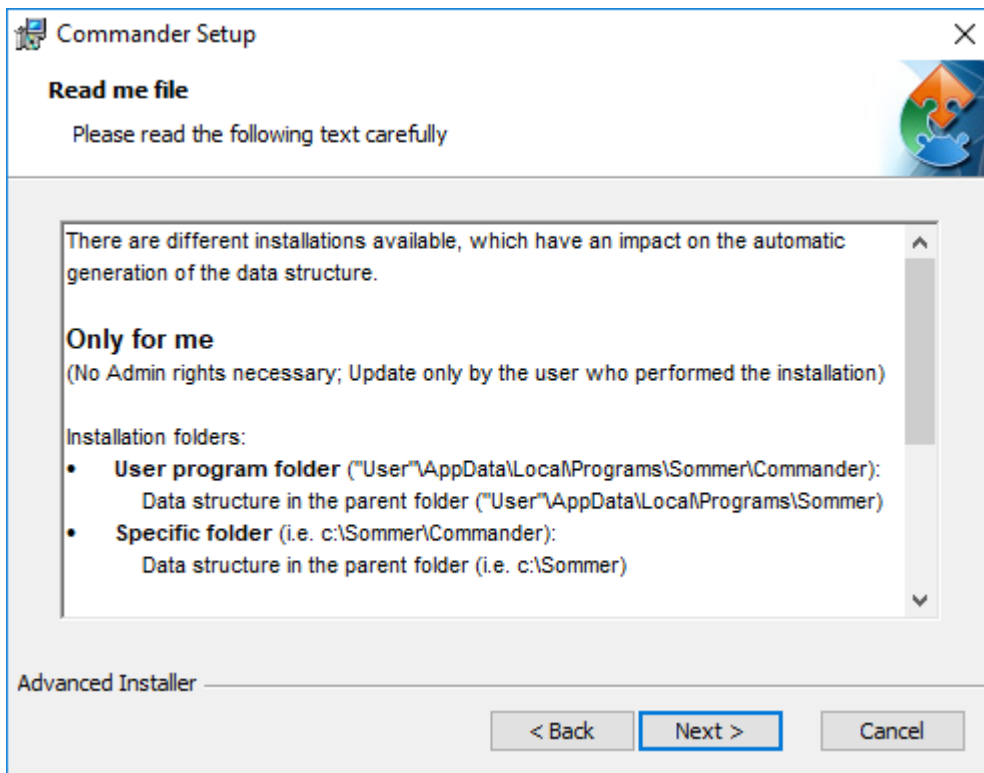

5. Select the installation type and click **Next**

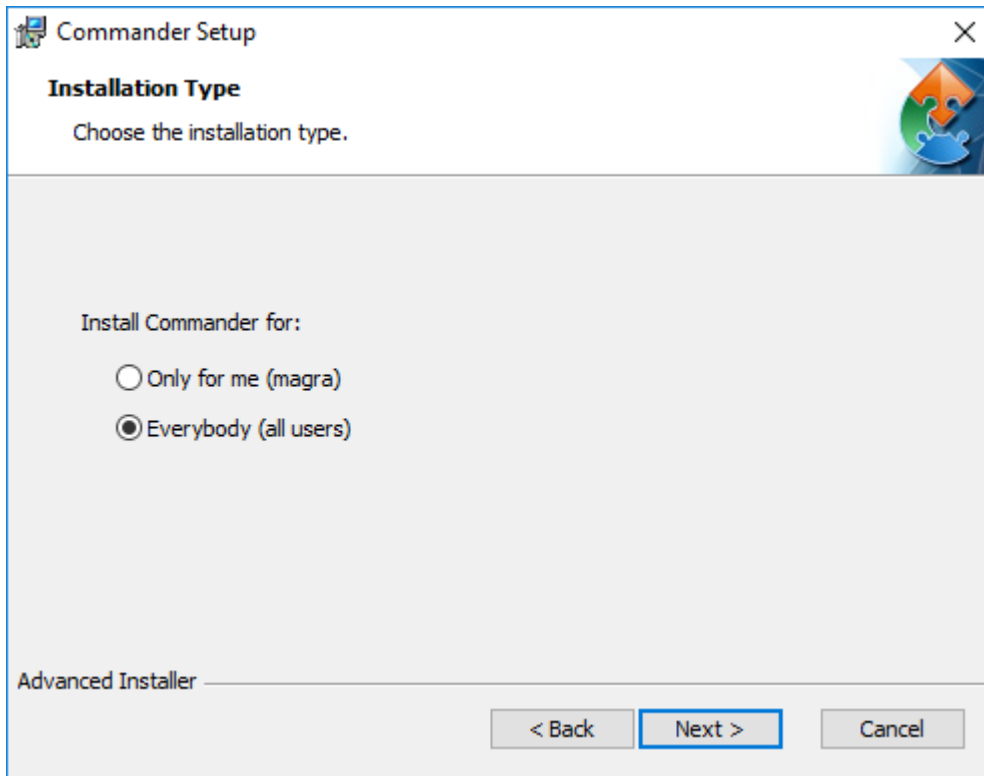

NOTE

Two installation types are available. Depending on the selection, the access rights and the folder structure differ:

Only for me

No admin rights are required. Updates are only available to the user who installed the software.

Installation folders:

- User program folder:
Users\User\AppData\Local\Programs\Sommer\Commander

Data structure:

Users\User\AppData\Local\Programs\Sommer

- Specific folder (default):

C:\Sommer\Commander

Data structure (default):

C:\Sommer

Everybody

Admin rights are required. Updates may only be performed by system administrators.

Installation folders:

- Standard program folder:
Program Files (x86)\Sommer\Commander

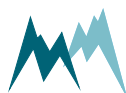



Data structure:

Users\Public\Public documents\Sommer

- Specific folder (default):

C:\Sommer\Commander

Data structure (default):

C:\Sommer

6. Select the installation directory and click **Next**.

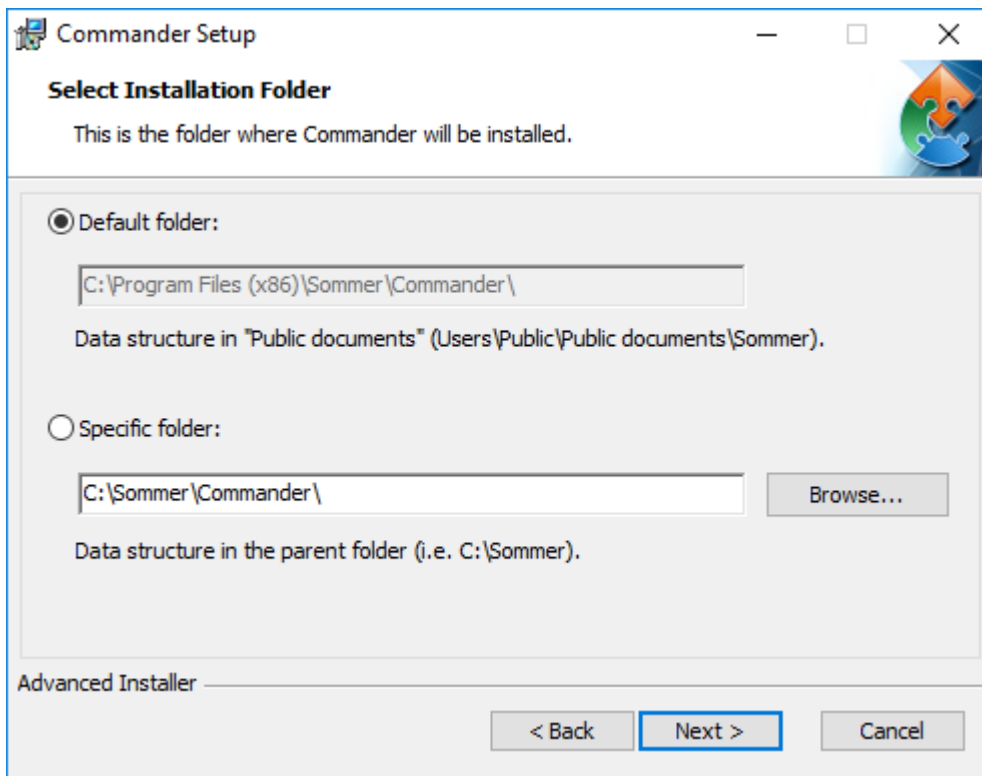

7. Select the features to be installed and click **Next**.

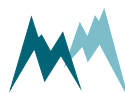

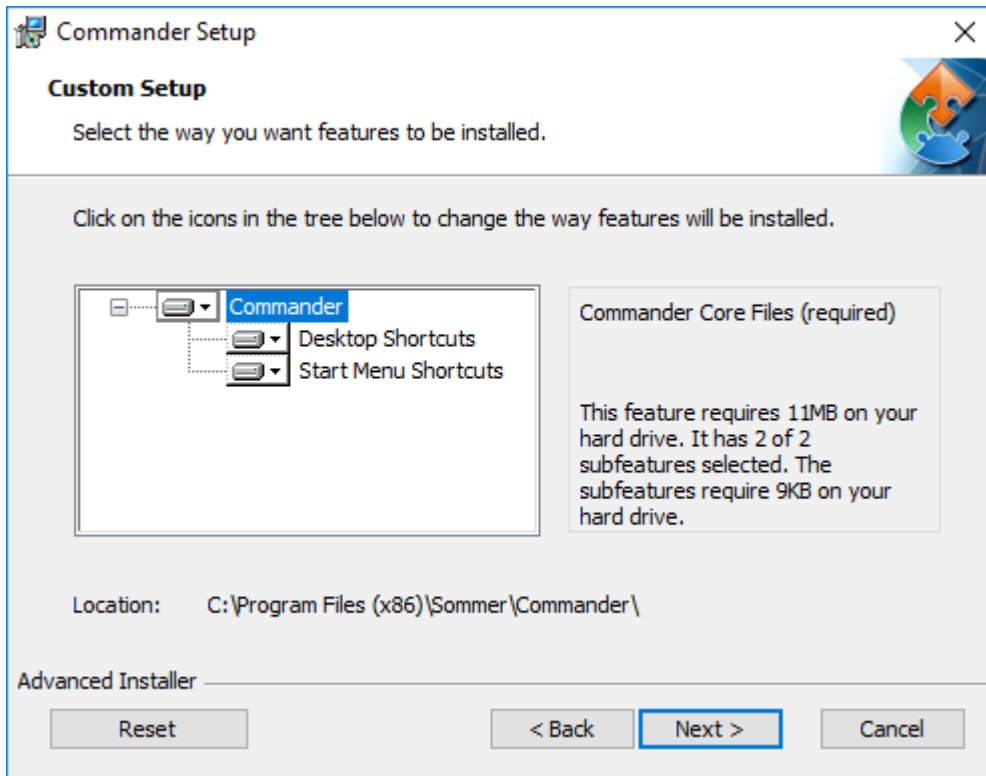

8. Click **Install** to start the installation.

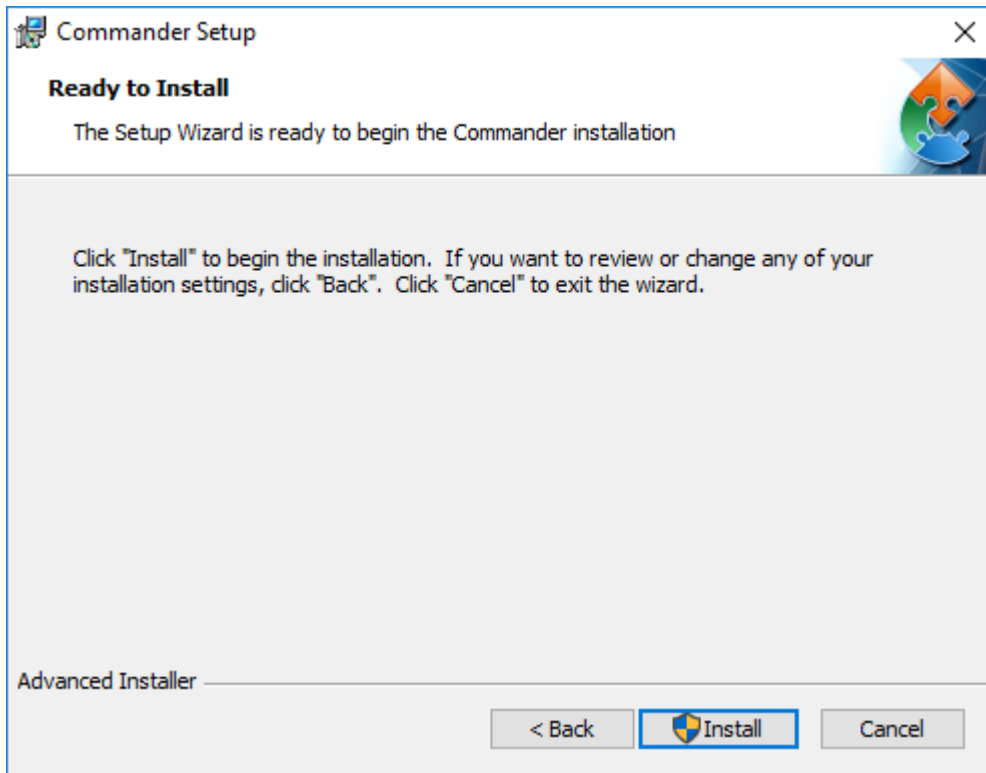

9. Click **Finish** to complete the installation.

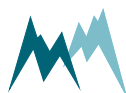

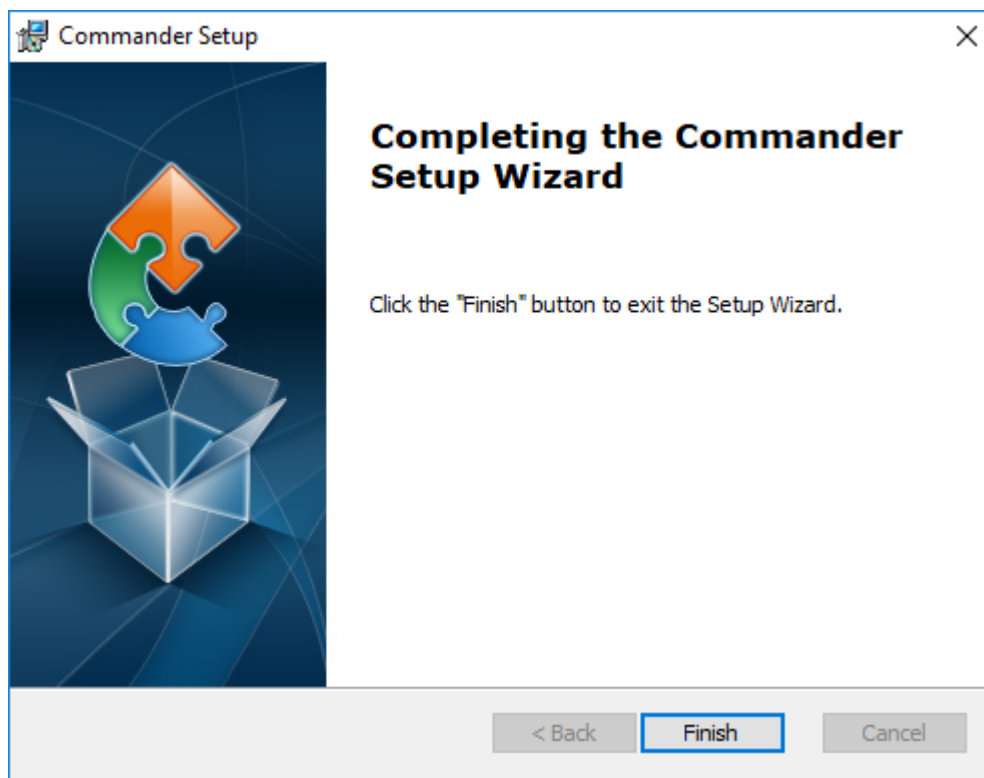

10.4 Sign-in to SQ-Commander

Please see the video on the online [Service center](#) for instructions.

10.5 Working with the SQ-Commander

Please see the videos on the online [Service center](#) for instructions on connections, setups and data management.

10.6 Working with data loggers

11 Configuration of the SQ-R

11.1 Software tools

The SQ-R can be configured with one of the following tools:

- Support software SQ-Commander

11.2 Conflict messages

During configuration with the SQ-Commander software, the SQ-R may return conflict messages after one or more parameters have been changed and uploaded to the device. An example is shown in [Figure 19](#).

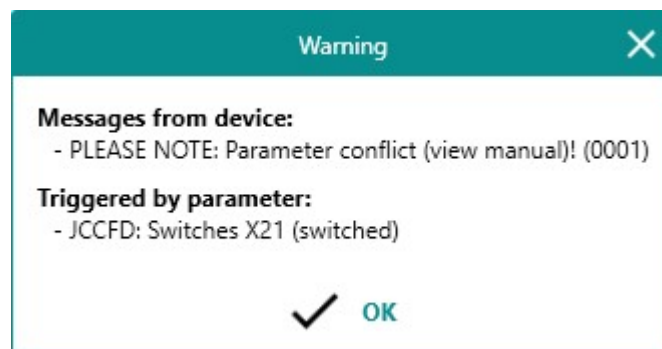

Figure 19 Example of a conflict message

The pop-up window lists the parameters and their indices which have triggered the warning. See [Parameter conflicts](#) for details.



ATTENTION If a conflict occurs, invalid settings are replaced automatically with valid values. Verify the values of the conflicting parameters and adapt them if needed!

11.2.1 Setup conflicts

A setup conflict message as listed below is returned if a modified setup with conflicting parameters is loaded onto the SQ-R.

Conflict code	Parameter	Comment
0002	Measurement output	Set to <i>just per command</i> if Output protocol (OP) is set to <i>Modbus</i> .
0010	River inclination	Set to <i>0</i> if Possible flow directions is set to <i>two (tide)</i> .
0040	Maximum velocity	Set to 5 m/s if value is ≥ 30 m/s or < 1.5 m/s.
0080	Minimum velocity	Set to 25% of Maximum velocity if $> 25\%$ of Maximum velocity. Set to 0.01 m/s if Maximum velocity is below 0.01 m/s.

Table 3 Setup conflict messages

11.3 General settings

When first setting-up a SQ-R at a measurement site, the parameters described below may need to be adapted.

11.3.1 Measurement trigger

Measurements are initiated by one of the options listed in the table below.

The commands to trigger measurements via RS-485 and SDI-12 are described in [Communication](#).

Measured data are either returned directly after the measurement or can be requested by commands via the RS-485 or SDI-12 interface. The format of the returned data can be configured in the sub-menu [Output protocol \(OP\)](#).

ID	Option	Description
1	Interval (default)	Measurements are initiated in a specified interval.
2	TRIG input	Measurements are triggered by the positive edge of a DC-voltage signal applied to the TRIG input (low: 0 ... 0.6 V, high: 2.2 ... 28 V, pulse duration must be ≥ 500 ms, delay between pulses must be ≥ 500 ms)
3	SDI-12/RS-485	Measurements are externally triggered by commands via RS-485 or SDI-12 from ,e.g. a data logger.

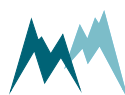

ID	Option	Description
4	all allowed	Measurement is triggered by all options mentioned above.

An internal measurement interval can be set for the SQ-R. If selected in menu item [Measurement trigger](#), measurements are performed in the defined interval. However, a measurement is always completed before a new one is initiated.

11.3.2 Language/Sprache

The menu language.

11.3.3 Decimal character

The character used as decimal separator in the values of the settings, in serial data strings and in .csv files.

11.3.4 Units and decimals

The units and number of decimal digits. These have to be set prior to all other settings as all values are saved internally in this format. They are set in the parameter menu [Units and decimals](#).



ATTENTION If units or decimals are changed, related parameters may need to be adjusted.

11.3.5 Output protocol (OP)

(missing or bad snippet)

(missing or bad snippet)

11.3.6 Information

The main measurement values are always included in the data output string. Additionally, special and analysis values can be included.

ID	Option	Description
1	Main values	Only the main values are returned.
2	& Special values (default)	Main values and special values are returned.
3	& Analysis values	Main, special and analysis values are returned.

11.4 Water level measurement

The settings for the water level measurement are defined under [Level \(W\)](#) and [Tech. level \(W\)](#).



ATTENTION Do not start the SQ-R while the target surface is within the blanking distance of the level sensor! Otherwise the SQ-R will not receive level measurements for several minutes! See [Specifications](#) for the blanking distance of your sensor.

11.4.1 WMA, maximum level

The maximum expected water level (see [Figure 20](#)). It represents the upper limit of the W-v relation and is required for W-v learning.

11.4.2 WLL, low level border

The water level below which velocity measurements are not feasible (see [Figure 20](#)). It represents the lower limit of the W-v relation. A guidance value is 5 cm above the river bed or any protruding stones in the measurement area.



ATTENTION Below the low level border no velocity measurement is performed any more.

11.4.3 WCF, cease to flow level

The water level at which the flow velocity is always zero (see [Figure 20](#)).

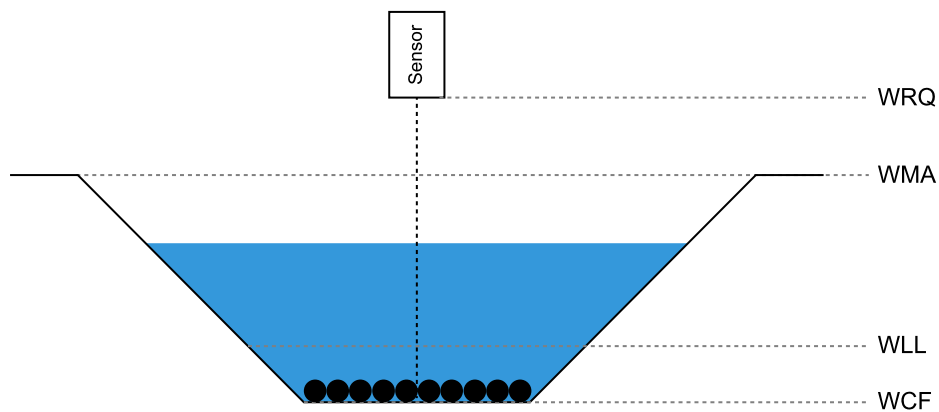

Figure 20 Designation of water levels

In general, the predefined water levels respect the rule: $W_Q, Q-30 > WMA > WLL > WCF$

11.4.4 Adjustment

The most important setting for water level and discharge measurements is the level adjustment. It is essential that the measured water level W is referenced to the levels in the cross-Sectional profile and the discharge table (see Section [Performing a site survey](#)).

The procedure to adjust the level is different for sites with and without existing water level measurements.

Adjustment with known water level

The adjustment with an existing water level measurement is simple as the actual water level is known. However, it is essential that the gauge zero GZ of the existing water level measurement is defined as the reference level for the discharge table.

The water level measurement of the SQ-R sensor is set to the known value by the following steps:

1. Click the button [Adjustment](#) in the parameters list. This initiates a water level measurement and the measured level is displayed.
2. Enter the water level of the existing measurement. After confirmation the water level measurement of the SQ-R sensor is adjusted to the given value and the entry for the mounting height W_Q is updated.

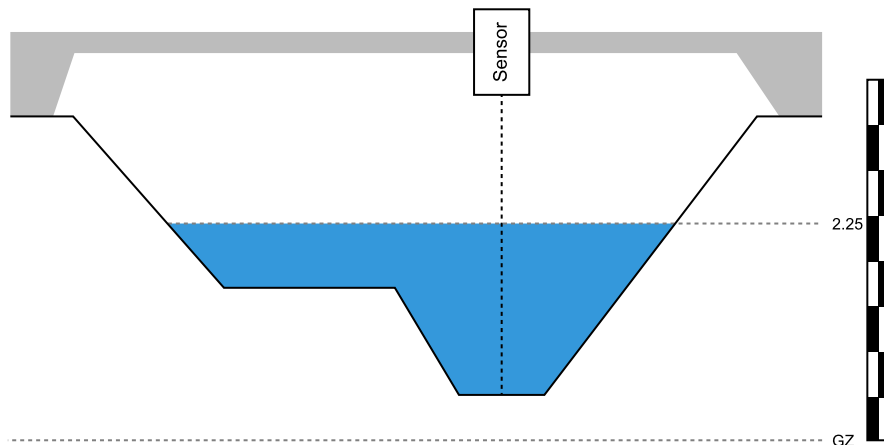

Figure 21 Water level adjustment with known water level

Adjustment with unknown water level

If the water level at the measurement site is not known, the mounting height of the SQ-R sensor W_Q can be set directly. To do this, the exact vertical position of the SQ-R sensor in the reference coordinate system must be determined.

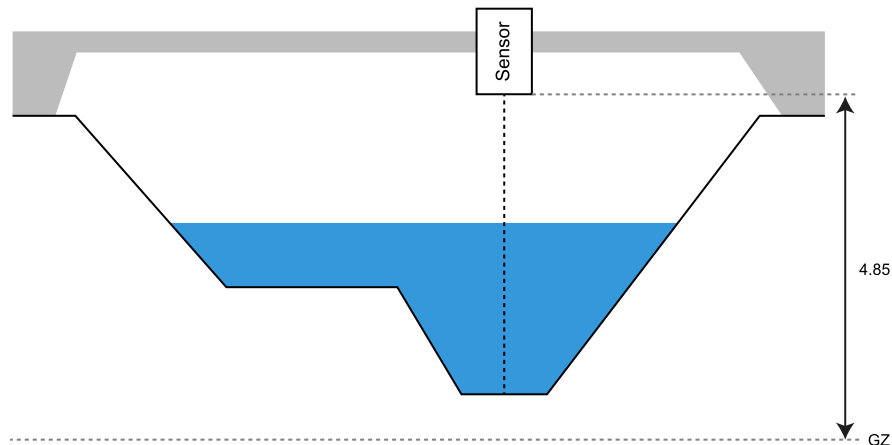

Figure 22 Water level adjustment by setting of the mounting level W_Q of the SQ-R

Setting of the special water levels

The velocity measurement might be obstructed at low water levels. If the level drops below WLL, the velocity measurement is stopped to avoid erroneous measurements. However, the water level

measurement is still performed and the discharge is determined by interpolating the velocity between WLL and WCF. The velocity at WLL is calculated from the W-v relation.

11.5 Velocity measurement

The measurement of the flow velocity depends on the mounting position of the SQ-R sensor and the water flow conditions at the site. These conditions are defined by the settings under [Velocity](#) and [Tech. velocity \(v\)](#)

11.5.1 Viewing direction

The viewing direction of the SQ-R sensor in relation to the flow direction of the river, either *upstream* or *downstream*.

11.5.2 Possible flow directions

The setting to define if the river only flows in one direction or if two flow directions can occur, e.g. under tidal influence (see also [Flow direction separation](#)).

11.5.3 Measurement duration

The duration of a single measurement. During this time the velocity radar signal is recorded and the radar spectrum is calculated. Generally, a measurement duration of 30 s is recommended. For very calm rivers a longer measurement duration should be selected.

11.5.4 Minimum velocity

The minimum expected velocity. No lower velocities are considered.

11.5.5 Maximum velocity

The maximum expected velocity. The velocity measurement is optimized for this setting. Usually a value of 5 m/s is adequate.

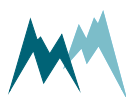

11.5.6 Meas. spot optimization

The expected velocity distribution in the measurement spot. The more irregular the distribution, the wider the selected spectral band width used for the velocity measurement.

For the first measurements at a new site the option *standard* is recommended. Later on, the measurement may be optimized by selecting another option.

11.5.7 Measurement type

The velocity measurement can either be performed continuously in one block, or in a sequence of five consecutive blocks with breaks in between. The sequenced method is more representative but slower. By default the selection should be set to *continuous*.

11.5.8 Criteria for invalid measurements and their handling

Velocity measurements can be defined as invalid by the criteria quality (SNR) and opposite direction content (*Stop, min. quality (SNR) to Stop, replace value*). These criteria and the handling of invalid measurements are controlled with these settings. Please refer to [Tech. velocity \(v\)](#) for details.

11.5.9 Inclination measurement

As described in [Inclination angle measurement](#) each velocity measurement has to be corrected for sensor inclination. If the SQ-R sensor is mounted stably it is sufficient to measure the installation angle with the first measurement after a sensor restart. If the sensor can move it is recommended to perform an inclination measurement with each velocity measurement.

11.5.10 View spectral distribution

With this function the SQ-R radar sensor is switched into spectrum mode and the spectra are recorded by the SQ-Commander and displayed in the [Measurement](#) tab. Please refer to [Radar spectrum](#) for more details on velocity radar spectra.

11.6 Discharge table

To calculate the discharge from water level and velocity measurements, a discharge table is required. This table is generated during the site survey as described in [Performing a site survey](#).

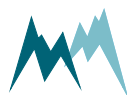

The discharge table can be edited directly in the parameter menu [Discharge table](#) or uploaded to the SQ-R sensor via the Profile tab of the SQ-Commander software.

11.7 W-v relation

Generally, water level W and flow velocity v are related. If this relationship is assumed to be stable discharge rates can be deduced from water level measurements only. This functionality is implemented in the SQ-R sensor as W - v learning, which means that the sensor continuously adjusts an internally stored W - v curve with each new measurement.

11.7.1 Usage

The W - v relation can be used to smooth velocity measurements and discharge rates. Generally, the water level fluctuates only slightly while the flow velocity can vary considerably depending on the flow conditions. By applying the learned W - v relation to the water level measurements velocity and discharge data can be smoothed.

Additionally, the W - v relation is used to interpolate flow velocities for water levels between the low level border WLL and the cease to flow level WCF as shown in [Figure 23](#). Such conditions occur if stones impair the velocity measurement or if the sensor points to dry areas. For these low water levels the velocities can be interpolated from the W - v relation and thus provide valid velocity and discharge values.



ATTENTION If no stable W - v relation is present at the measurement site the learned W - v relation will provide unstable results as well.

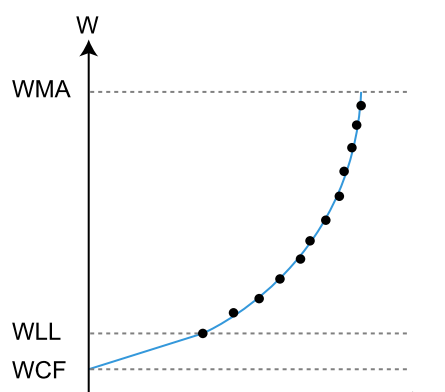

Figure 23 Interpolation of the flow velocity between WLL and WCF

11.7.2 Learning of the W-v relation

For the water level range between the maximum level WMA and the low level border WLL a table with 16 value pairs consisting of water levels and learned velocities is created. The learned velocities in the table are continuously adjusted with each new measurement. With time, the complete water level range is covered with learned velocities and a relatively stable relation between water level and velocity is generated, provided the measurement site allows this. Consequently, for each measured water level a learned velocity and a learned discharge can be assigned by linear interpolation.



ATTENTION The time needed to generate a complete W-v learning curve strongly depends on the fluctuations of the water level at the measurement site.

11.7.3 Water levels for the W-v relation

The range of water level, in which the W-v relation is learned, is defined by the special water levels WMA, WLL and WCF (see [Water level measurement](#)).

11.7.4 Activation

Usage of the W-v relation is activated as soon as one of the special water levels WMA, WLL or WCF is different from zero.

11.7.5 W-v priority

By default the W-v priority is set to *no* and the measured velocity and discharge are returned as main values. The learned velocity and discharge are returned as special values.

If the W-v priority is set to *yes* the learned velocity and discharge are returned as main values. The measured velocity and discharge are returned as special values.

11.7.6 W-v table reset

With this function the existing W-v table is deleted and the W-v learning starts anew. This is required if any of the special water levels WMA, WLL or WCF have changed or if the SQ-R sensor is moved to an-other measurement site.

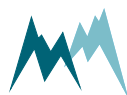

12 Communication

12.1 Communication protocols

The SQ-R provides the following communication protocols:

- [RS-485](#) (Sommer bus protocol)
- [Modbus](#)
- [SDI-12](#)

12.2 Data output

The measurement values returned by the SQ-R are arranged in a fixed sequence and identified by an index. They are divided into three groups and can be selected in [Information](#).

12.2.1 Main values

The main values comprise the primary measurement values as listed below and are always returned with the data string. Units and decimal places can be set in [Units and decimals](#).

Index	Measurement value	Unit	Description
01	Self-check	-	ID of self-check function (see Device status)
02	Water level	2	Measured water level
03	Velocity ¹ .	2	Measured velocity
04	Quality (SNR)	-	Quality value containing SNR
05	Flow ¹	2	Measured discharge
06	Flow sum	2	Total discharge volume

Table 4 Main values

¹The location of the measured and learned velocities and discharges in the output can be switched with the menu item [W-v priority](#)

²Unit according to sub-menu [Units and decimals](#)

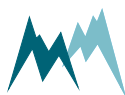

12.2.2 Special values

The special values comprise the learned velocity and discharge as well as some diagnostic values (see 12.2.2). By activating the W-v priority with the menu item **W-v priority** the measured velocity and discharge are returned instead (The learned velocity and discharge are then returned with the main values).

Index	Measurement value	Unit	Description
07	Learned Velocity ²	1	Learned velocity of W-v relation
08	Learned flow ²	1	Discharge calculated from learned velocity
09	Opposite direction content	%	Fraction of counter-flow in measurement direction
10	Supply voltage	V	Voltage of the power supply input

Table 5 Special values

12.2.3 Analysis values

The analysis values as listed in 12.2.3 comprise diagnostic information of the velocity measurement.

Index	Measurement value	Unit	Description
11	Peak width	mm/s	Band width of the signal
12	CSR	%	Corrected intensity
13	Area of the peak	-	-
14	RMS at the PIC	mV	Diagnostic variable
15	Amplification	-	Value of the amplification regulation
16	Amplification relation	%	Diagnostic variable
17	Signal relation	%	Diagnostic variable
18	Error code	-	for diagnostic use of Sommer Messtechnik only

Index	Measurement value	Unit	Description
19	not used	-	-
20	not used	-	-
21	not used	-	-

Table 6 Analysis values

12.2.4 Quality value

The quality value provides information about the velocity measurement and distribution and has the format: -21.89

	Description
-	Validity of the measurement
21	SNR in dB
8	Amplification, 0...9
9	Band width class, 0...9

Validity of the measurement

Measurements with a negative quality value have been identified as invalid (so-called stop measurements).

A velocity measurement is flagged invalid if the opposite direction content exceeds the threshold defined in [Stop, max. opp. direction](#) or if the quality value is below the [Stop, min. quality \(SNR\)](#) limit.

SNR

The Signal-to-Noise Ratio contains the most important information of the quality value. Generally, a SNR lower than 30 indicates an insufficient flow velocity measurement.

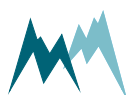

Amplification

Depending on the condition of the water surface, e.g. waves, and the distance between water surface and sensor the received radar signals may fluctuate considerably. To compensate for these fluctuations the radar signal is amplified accordingly.

A high amplification value indicates a weak radar signal; a value of 0 is optimal.

Band width class

The band width class depends on the spectral velocity distribution. Generally, a high band width corresponds to a turbulent river, i.e. *Splash water*, a low band width to a calm river, i.e. *consistent*. This classification may not be very accurate. Observations of the flow conditions at the measurement site always have to be considered.

12.2.5 Exception values

Measurement data may be returned with the following exception values:

Value	Description
99999998	Initial value: No measurement has been performed yet.
99999997	Conversion error: Caused by a technical problem.
99999999	Positive overflow
-99999999	Negative overflow

Table 7 Exception values

12.3 RS-485

12.3.1 What is RS-485?

RS-485 is a serial communication method for computers and devices. It is currently a widely used communication interface in data acquisition and control applications where multiple nodes com-

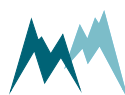

municate with each other.¹

12.3.2 What can I do with it?

RS-485 communication is primarily used to trigger measurements and read their results. It also permits to change parameters of the SQ-R.

12.3.3 Configuration

The SQ-R has serial RS-485 communication enabled by default. If the device is integrated into a RS-485 network or connected to a stand-alone data acquisition system, e.g. a data logger, the parameters listed in [RS-485 Protocol](#) may need to be adapted.

System key and device number

The system key and device number are used to identify a SQ-R in a bus system. This is essential if multiple devices (SQ-R and data loggers) are operated within the same system.

System key

The system key separates different conceptual bus systems. This may be necessary if the remote radio coverage of two measurement systems overlap. In wired setups, the system key should be set to *00*.

Device number

The device number is a unique number that identifies a device in a bus system.



ATTENTION Do not use a device number twice in your bus system!
Otherwise communication will fail!

Measurement output

The serial data output can be triggered in the following ways:

¹<https://www.lammertbies.nl/comm/info/RS-485.html>



ID	Option	Description
1	Just per command	The output is only requested by commands via RS-485.
2	After measurement (default)	The serial data output is performed automatically right after each measurement.
3	Pos. TRIG slope	The output is triggered by a positive edge of a control signal applied to the trigger input.



NOTE If *Measurement output* is set to *pos. TRIG slope*, the data are returned with a delay of 200 ms after the trigger has been set. Make sure that your data acquisition system takes account of this lag to ensure that it receives the most recent data.

Operation modes

The selected combination of measurement trigger and output time determines the following operation modes:

Parameter	Mode		
	Pushing	Polling	Apparent polling
Measurement trigger	internal	TRIG input SDI-12/RS485	TRIG input SDI-12/RS485
OP, measurement output	after measurement	just per command	after measurement

Waking-up a connected data logger

The SQ-R supports wake-up of a connected data logger that is in standby mode. Generally, this feature is only used in pushing mode and can be set under [Wake-up sequence](#).

Sync sequence

The sync sequence is the string `UU~???` and is sent directly before a command. It is used to synchronize the receiving UART.

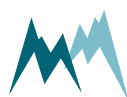

Prefix

The prefix is an arbitrary character; the SQ-R uses a blank. This character is sent prior to any communication. Then the time of the [Prefix holdback](#) is waited and the command is sent afterwards. With this procedure the receiving device has time to wake-up.

Output protocols

For data output via RS-485 different protocols are available, which can be selected under [Output protocol \(OP\)](#).

12.3.4 Data output options

Data are returned in two different formats, selectable in [Output protocol \(OP\)](#):

- [Sommer bus protocol \(SBP\)](#)
- [Standard protocol](#)
- [Sommer old protocol](#)

12.3.5 Sommer bus protocol (SBP)

The data string of the Sommer protocol has the following format:

 **EXAMPLE** #M0001G01se01 1461|02 1539|03 25.25|04
0|3883;

A data string contains max. 8 values and is max. 105 characters long.

Header

The header (#M0001G00se) identifies the data by system key, device number and string number.

Parameter	Format	Description
Start character	#	
Identifier	M	M identifies an output string
System key	dd	

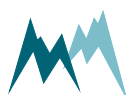

Parameter	Format	Description
Device number	dd	
Command ID	G	G defines an output string with string number
String number	dd	01 Main values 03 Special values 05 Analysis values 06 Analysis values
Command	se	se identifies automatically sent values

Table 8 Header of the Sommer protocol

Measurement value

A measurement value (02 1539 |) has a length of 8 digits and is returned together with its index. If the measurement value is a floating point number, one digit is reserved for the decimal character. Values are returned right-aligned, so blanks may occur between index and value.

Parameter	Format	Description
Index	dd	2 numbers
Value	xxxxxxxx	8 character right-aligned
Separator		

Table 9 Values in Sommer protocol

End sequence

The data string is terminated with a CRC-16 in hex format (3883) followed by an end character and <CR><LF>. The CRC-16 is described in [Sommer CRC-16](#).

Parameter	Format	Description
CRC-16	Hhhh	4-digit hex number
End character	;	
Control characters	<CR><LF>	Carriage return and Line feed

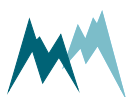

Table 10 End sequence of the Sommer protocol

Example Sommer protocol

Main values

Main values are returned as in the following example:

✓ **EXAMPLE** #M0001G00se0199999998|02 8806|03 0.433|04
40.93|05 0.00|06 5369.36|59DF;

#M0001G00se	Header with system key 00, device number 01 and string number 00
0199999998	No value assigned, always 99999.98
02 8806	Water level
03 0.433	Flow Velocity ¹
04 40.93	Quality (SNR) (see Quality value)
05 0.00	Flow ⁵
06 5369.36	Flow sum
59DF;	Closing sequence

Table 11 Main values in Sommer protocol

Special values

Special values are returned as in the following example:

✓ **EXAMPLE** #M0001G01se07 0.000|08 0.00|09 46|10
15.13|E30C;

#M0001G01se	Header with system key 00, device number 01 and string number 01
-------------	--

¹The positions of the measured and learned velocity and discharge can be switched with the menu item *W-v priority*.

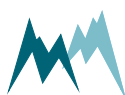

07	0.000	Learned velocity ¹
08	0.00	Learned discharge ¹
09	46	Opposite direction content
10	15.13	Supply voltage
E30C ;		Closing sequence

Table 12 Special values in Sommer protocol

Analysis values

Analysis values are returned as in the following example:

✓	EXAMPLE			
	#M0001G02se11	430 12	293 13	78 14
	116 15	11075 16	-40 E08D;	
	#M0001G03se17	0 18	0 19	9999998 20
	9999998 21	9999998 3827;		

#M0001G02se		Header with system key 00, device number 01 and string number 02 for the analysis values 11 to 16
11	430	Peak width [mm/s]
12	293	CSR [%]
13	78	Area of the peak
14	116	RMS at the PIC
15	11075	Amplification
16	-40	Amplification relation [%]
E08D ;		Closing sequence
#M0001G03se		Header with system key 00, device number 01 and string number 03 for the analysis values 17 to 21
17	0	Signal relation [%]

18	0	Error code
19	9999998	not used
20	9999998	not used
21	9999998	not used
3827 ;		Closing sequence

Table 13 Analysis values in Sommer protocol

12.3.6 Standard protocol

The data string of the Standard protocol has the following format:

	EXAMPLE M_0001	1461	1359	25.38	0
---	-----------------------	------	------	-------	---

Header

The header (M_0001) identifies the data by system key and device number.

Parameter	Format	Description
Identifier	X_	M_ Measurement values S_ Special values V_ Analysis values
System key	Dd	
Device number	Dd	

Table 14 Header of the Standard protocol

Measurement values

Measurement values are returned in sequence and are separated by a blank. A measurement value has a length of 8 digits. If the measurement value is a decimal number, one digit is reserved for the decimal character. Values are returned right-aligned, so additional blanks may be returned between values.

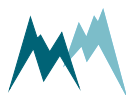

Parameter	Format	Description
Separator	[blank]	blank
Value	xxxxxxxx	8 character right-aligned

Table 15 Values in Standard protocol



NOTE With the standard protocol the data strings can be very long. In contrast, the strings of the Sommer protocol are max. 105 characters long.

End sequence

The data string is terminated with <CR><LF>.

Example Standard protocol

Main and special values

Main and special values are returned as in the following example:

	EXAMPLE	M_0001	99999998	6458	0.679	35.93
		0.00	99999.98	0.679	0.00	46
						15.13

M_0001	Header with identifier for measurement values
99999998	No value assigned, always 99999998
6458	Water level
0.679	Velocity ¹
35.93	Quality (SNR) (see Quality value)
0.00	Flow6

¹The positions of the measured and learned velocity and discharge can be switched with the menu item [W-v priority](#).

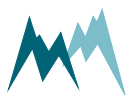

99999.98	Flow sum
0.679	learned velocity ⁶
0.00	learned discharge ⁶
46	Opposite direction content
15.13	Supply voltage

Table 16 Main and Special values in Standard protocol

Analysis values

Analysis values are returned as in the following example:

✓	EXAMPLE	z_0001	664	239	61	91
		11075	47	0	200	9999998
		9999998;				9999998

z_0001	Header with identifier for analysis values
664	Peak width [mm/s]
239	CSR [%]
61	Area of the peak
91	RMS at the PIC
11075	Amplification
47	Amplification relation [%]
0	Signal relation [%]
200	Error code
9999998	not used
9999998	not used
9999998	not used

Table 17 Analysis values in Standard protocol

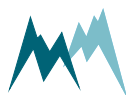

12.3.7 Sommer old protocol

The data string of the Sommer old protocol has the following format:

 **EXAMPLE** #M0001G00se00 -17.4|01 0.535|02 0.000|03
-1.89|04 0.0|05 0|B11D;

This protocol is identical with the Sommer protocol except that the index of the measurement values starts at 0 instead of 1.

This protocol has been implemented for compatibility reasons: When a Sommer device with firmware < 2.0 is updated to version 2.x the protocol is automatically set to Sommer old. Thus, the setup of a connected data logger does not have to be adjusted.

12.3.8 RS-485 commands

Command structure

The structure of serial commands and answers is described in the following table:

Parameter	Format	Description
Start character	#	
Identifier	X	<p>W Write: SQ-R returns a confirmation on receipt. This command type demands a closing sequence with a valid CRC-16.</p> <p>S Silent: SQ-R does not acknowledge the receipt of the command. This command type demands no closing sequence and therefore no CRC-16.</p> <p>R Read: SQ-R returns the requested measurement value or parameter. This command type demands a closing sequence with a valid CRC-16.</p> <p>T Temporary: Write a volatile, temporary setting and receive a confirmation.</p> <p>A Answer: Answer of device to read or write command.</p>
System key	dd	

Parameter	Format	Description
Device number	dd	
Command	xxx	See table in section Commands .
Separator		
CRC-16	hhhh	4-digit hex number
End character	;	

Table 18 Structure of Sommer bus commands and answers

Commands

The following commands can be used with the SQ-R:

Command	Description
\$mt	Trigger a measurement
\$pt	Return measurement values
XX	Read a parameter with identifier XX
XX=xxxx	Write a parameter with identifier XX and the value xxx

Table 19 List of Sommer bus commands

Trigger a measurement

The command \$mt triggers a complete measurement sequence as in the following example:

	EXAMPLE #W0001\$mt BE85;	Answer: #A0001ok\$mt 4FA9;
---	---------------------------------	----------------------------

Read a parameter value

Read measurement interval (in the example below the menu item B):

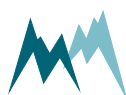



EXAMPLE #R0001B|228E;

Answer: #A0001B=300|F8B3;

Request a complete data string

The command \$pt requests a data string as in the following example:



EXAMPLE

Option 1

#W0001\$pt|7D19;

Answer: #A0001ok\$pt|8C35;

Option 2

#S0001\$pt|

Answer: none

The data string is returned as soon as the SQ-R has processed the command. If a wrong command is entered, the device returns #A0001na\$pt|3D40;.

Request a single measurement value

The reading command R together with the index of the requested measurement returns a single measurement value. In the following example the measurement value with index 01 (in this example a water level) is requested:



EXAMPLE

#R0001_010cv|EA62;

Answer: #A0001ok_010cv1461 |07EB;

12.3.9 Sommer CRC-16

The CRC-16 (cyclic redundancy check) used in data transmission of Sommer devices is based on the ZMODEM protocol. When data are exchanged between two devices the receiving device calculates the CRC-value. This value is compared to the CRC value sent by the other device to check if the data were transmitted correctly. Please refer to technical literature or contact Sommer for calculation of CRC-16 values.

You can [here](#) calculate the CRC of a command online .

If you need to compute CRCs automatically, you can implement the following procedure in your data logger or controller software.

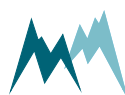

The CRC-16 is calculated character by character. The start value for the initial CRC-16 calculation is always 0.

The following procedure returns the CRC-16 of a single character:

```

byte1 = CRC-16 right shift by 8 bits           upper byte disappears
uint1 = c                                     new character, upper byte = 0
uint2 = CRC-16 left shift by 8 bits          lower byte = 0
uint3 = crc16tab[byte1]                       Table value from the CRC-16 table
Crc16 = uint3 (excl. or) uint2 (excl. or) uint1

```

Computation CRC-16 in C/C++

```
1 | crc16 = crc16tab[(unsigned char)(crc16>>8)] ^ (crc16<<8) ^ (unsigned int)(c);
```

The `crc16tab` array is listed in [CRC-16 array](#).



EXAMPLE

Command to request measurement data `#W0001$pt|7D19;`

The first character is #, the last |. The CRC-16 of the command is 7D19 and its end character is ;.

The CRC-16 is calculated sequentially with the start value 0 for the initial CRC-16 calculation:

Position	String	CRC-16
Start		0000
0	#	0023
1	#W	2357
2	#W0	4331
3	#W00	4997
4	#W000	4EDD
5	#W0001	743B
6	#W0001\$	0537
7	#W0001\$p	67D5
8	#W0001\$pt	C935
9	#W0001\$pt	7D19

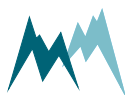

12.4 SDI-12

12.4.1 What is SDI-12?

SDI-12 (Serial Data Interface at 1200 Baud) is a serial data communication standard for interfacing multiple sensors with a single data recorder. For a detailed description on SDI-12 communication please refer to www.sdi-12.org.

12.4.2 What can I do with it?

The SQ-R listens to standard SDI-12 commands as listed in the SDI-12 specifications of version 1.3, e.g., to trigger a measurement or retrieve measurement results. Additionally, a set of extended SDI-12 commands is implemented in all SOMMER sensors for instrument configuration.

12.4.3 Configuration

The SQ-R has SDI-12 communication enabled by default. When setting up a SDI-12 network take the following considerations into account:

- Each device in the SDI-12 network must have a unique address, e.g. data logger address *0*, SQ-R address *1*.
- If the SQ-R operates in polling mode (**Measurement trigger** set to *SDI-12/RS-485*), measurements are triggered by *M!* commands and data are retrieved by *D!* commands.
- If the SQ-R operates in pushing mode (**Measurement trigger** set to *interval*), data are retrieved by the *R!* commands.
- When multiple sensors are connected to the same network, data acquisition should be done in sequence, i.e., data should have been received from the first sensor before triggering the measurement of the second sensor.
- Most data loggers control the timing of messages (marking and spacing) automatically. If this is not the case, please refer to www.sdi-12.org.

12.4.4 Data structure

The answer from the SDI-12 device is a string containing the sensor address, the requested data and a terminating carriage return/line feed.

In a string containing measurement data, the measurements are returned in the same order as listed by the index in [Data output](#).



**EXAMPLE**

```
0+2591+706+25.53+62<CR><LF>
```

Value	Content
0	Sensor address
2591	Measurement with index 01
706	Measurement with index 02
25.53	Measurement with index 03
62	Measurement with index 04

If a device returns more than 9 measurement values, or if the values are returned in groups (see also [Request results](#)) the measurement index increments in the next group.

**EXAMPLE**

```
0D0! Answer: 0+2591+706+25.53+62<CR><LF>
```

```
0D0! Answer: 0+56.2+125+12.32<CR><LF>
```

Value	Content
0	Sensor address
2591	Measurement with index 01
706	Measurement with index 02
25.53	Measurement with index 03
62	Measurement with index 04
0	Sensor address
56.2	Measurement with index 05
125	Measurement with index 06
12.32	Measurement with index 07

12.4.5 SDI-12 commands

The following tasks can be performed with standard and extended SDI-12 commands.

Extended SDI-12 commands are non-standard commands implemented by SOMMER to enable device configuration via SDI-12.

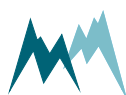



NOTE After any changes, the settings have to be adopted with the command `aXW_ts|!`, with `a` the sensor address.

Command structure

A standard SDI-12 command starts with the sensor address and ends with an exclamation mark, e.g., `0M!` to trigger a measurement.

Configuration commands contain additional information; see the sections below for details.

Identify device

The identification of a SDI-12 device is requested with the command `aI!`, with `a` the sensor address.



EXAMPLE

```
0I!      Answer 013Sommer  USH  140r90  USH-9  <CR><LF>
```

The answer contains the following information:

0	SDI-12 address
1	SDI-12 version prior to the point
3	SDI-12 version after the point
Sommer	Description of the company (6 characters and 2 blanks)
USH	Description of the firmware (5 characters and 2 blanks)
140r90	Firmware version (6 characters and 2 blanks)
SQ-R	Device designation (max. 13 characters)

Acquire measurements

To acquire a measurement from a sensor, two individual SDI-12 commands – trigger a measurement and request measurement values – need to be sent.

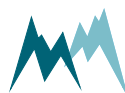

**EXAMPLE**

0M! Answer: 00084<CR><LF> and 0<CR><LF> after 8 seconds

0D0! Answer: 0+2591+706+25.53+0<CR><LF>

The first values in the response to the aDn! command is the sensor address.

Trigger measurement

The command aM! with sensor address a triggers a measurement as in the example below.

The response states the measurement duration and the number of measurement values (see example below). After completion of the measurement, the device will return an additional a<CR><LF>, with a the sensor address.

**EXAMPLE**

0M! Answer: 00084<CR><LF> and 0<CR><LF> after 8 seconds

The answer contains the following information:

0 SDI-12 address

008 Duration of the measurement in seconds

4 Number of measurement values

Request results

After each measurement, results are requested with the command aDn!, with a the sensor address and n the index of the returned data string.



EXAMPLE 0D0! Answer: 0+2591+706+25.53+0<CR><LF>

The leading 0 of the response is the sensor address.

Generally, the command aD0! is sufficient to request up to 9 measurement values. If more than 9 values need to be read, or if the values are returned in groups, the commands aD1!, aD2!,... may need to be issued after aD0!. For example, if a measurement returns 8 values in two groups of 4, the commands aD0! and aD1! need to be issued to receive all values.

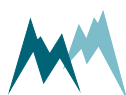

Acquire continuous measurements

If the SDI-12 device is operating in continuous measurement mode (not polled by SDI-12), the command `aR0!` will request and return the current reading of the sensor. The values within the data string follow the order listed in the measurement table. The first values in the response to the `aRn!` command is the sensor address.



EXAMPLE

`0R0!` Answer: `0+2591+706+25.53+0<CR><LF>`

If more than 9 values need to be read, or if the values are returned in groups, the commands `aR1!`, `aR2!`,... may need to be issued after `aR0!`. For example, if a measurement returns 8 values in two groups of 4, the commands `aR0!` and `aR1!` need to be issued to receive all values.

Configure parameter

The configuration parameters of a SOMMER sensor are read with the command `aXRpp!` and written with the command `aXWpp=vvv!`, with `a` the sensor address, `pp` the parameter identifier and `vvv` the value of the parameter.

Read and write a parameter



EXAMPLE

Reading of measurement interval (in this example menu item B)

`0XRB|!` Answer: `0B=300|<CR><LF>`

Setting of measurement interval to 60 s (in this example menu item B)

`0XWB=60|!` Answer: `0B=60|<CR><LF>`

Read and write a selector-parameter

Changing the measurement trigger (in the following example menu item A) from *interval* to *SDI-12/RS485*:

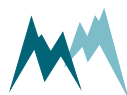

**EXAMPLE**`0XRA|!`Answer: `0A=1|<CR><LF>``0XWA=3|!`Answer: `0A=3|<CR><LF>`**Read and write a parameters of a table**

Some SOMMER sensors are equipped with multiple transducers and their settings are listed in a table (see example below). A value within such a table is addressed by its row-index (01, 02 ...) and column-index (A, B ...). A corresponding SDI-command has the following format:

**EXAMPLE**

In this example of a snow scale the value in row 01 and column B of the parameter D-D-E is changed to -1.4.

`0XWDDE01B=-1.4|!`Answer: `0DDE01b=-1.4|<CR><LF>`

	Identifier	offset zero kg	gain	zero default kg	gain default
01	Load Cell 1	-1.4	0,997787	0,000	0,997787
02	Load Cell 2	0,000	0,997787	0,000	0,997787
03	Load Cell 3	0,000	0,997787	0,000	0,997787
04	Load Cell 4	0,000	0,997787	0,000	0,997787

Adopt settings

Some settings need to be adopted with the command `aXW_ts|!`, with a the sensor address. It is recommended to issue `aXW_ts|!` after each configuration change.

12.5 Modbus**12.5.1 What is Modbus?**

Modbus is a serial communication protocol used for transmitting information over serial lines between electronic devices. The device requesting the information is called the Modbus Master and the devices supplying information are Modbus Slaves. In a standard Modbus network, there is one

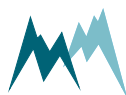

Master and up to 247 Slaves, each with a unique Slave Address from 1 to 247. The Master can also write information to Slaves.

Modbus has become a standard communication protocol in industry, and is now the most commonly available means of connecting industrial electronic devices. It is often used to connect a supervisory computer with a remote terminal unit (RTU) in supervisory control and data acquisition (SCADA) systems. Versions of the Modbus protocol exist for serial lines (Modbus RTU and Modbus ASCII) and for Ethernet (Modbus TCP).¹

12.5.2 What can I do with it?

Modbus-communication with SQ-R allows reading of measurement values and device information by a Modbus master. Additionally, the basic RS-485 port settings can be written to the SQ-R.

12.5.3 Wiring

For Modbus communication the SQ-R is wired according to the table below.

Modbus	Connector MAIN	Connection wire	Description
Common	1	White	GND
Vsupply	2	Brown	9...28 VDC
D1 - B/B	4	Yellow	RS-485 A
D0 - A/A	5	Grey	RS-485 B

Table 20 Modbus wiring



NOTE

Please note that different signal notations are in use for RS-485 connections:

TX+/RX+ or D+ or D1 as alternative for B

TX-/RX- or D- or D0 as alternative for A



NOTE If the SQ-R is operated with multiple Modbus devices within the same network, termination resistors may be required. Please contact Sommer Messtechnik for details.

¹<http://www.simplymodbus.ca/FAQ.htm>

12.5.4 How to switch the SQ-R to Modbus mode

Please see the video on the online [Service center](#) for instructions.

12.5.5 Modbus commands and registers

Read input registers

Input registers contain measurement values. The content of these registers is updated after each measurement.

	Register address	Variable	Unit / value	Bytes	Format
Test value	0	Hard coded test value	2.7519...	4	float
Main values	2	Self-check	2	4	float
	4	Water level	2		
	6	Velocity ¹	2		
	8	Quality (SNR)	-		
	10	Flow ¹	2		
	12	Flow sum	2		
Special values	14	Learned velocity ¹	2	4	float
	16	Learned flow ¹	2		
	18	Opposite direction content	%		
	20	Supply voltage	V		

¹The positions of the measured and learned velocity and discharge can be switched with the setting [W-v priority](#).

²Unit according to submenu [Units and decimals](#).

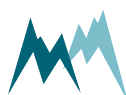

	Register address	Variable	Unit / value	Bytes	Format
Analysis values	22	Peak width	mm/s	4	float
	24	CSR	%		
	26	Area of the peak	-		
	28	RMS at the PIC	mV		
	30	Amplification	-		
	32	Amplification relation	%		
	34	Signal relation	%		
	36	Error code	-		
	38	not used	-		
	40	not used	-		
	42	not used	-		
Device info	65533	Device type and configuration	320X	2	unsigned int
	65534	Software version	XYZZZ	2	unsigned int
	65535	Modbus implementation version	10100	2	unsigned int

Table 21 Input registers

Read and write holding registers

Holding registers are mainly used to configure the Modbus adapter communication. Configuration settings are read with function 03 (read holding registers) and written with function 06 (write single registers).



NOTE Restart the Modbus adapter after changing the configuration!

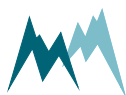

	Register address	Variable	Range	Bytes	Format
Config values	0	Modbus default ¹	0 - 1...read 1...write	2	unsigned int
	1	Modbus device address	1 to 247		
	2	RS-485 baud rate	1...1200 baud 2...2400 baud 3...4800 baud 4...9600 baud 5...19200 baud 6...38400 baud 7...57600 baud 8...115200 baud		
	3	RS-485 parity/ stop bits	1...no parity, 1 stop bit 2...no parity, 2 stop bits 3...even parity, 1 stop bit 4...odd parity, 1 stop bit		

Table 22 Holding registers

Report slave ID

The Modbus function 17 (report slave ID, read only) can be used to read basic information of the SQ-R. The following example shows the response of function 17 of a RG-30 sensor, which is received in hex-format:



EXAMPLE 23 11 26 53 FF 27 74 20 53 6F 6D 6D 65 72 20
20 52 47 2D 33 30 20 20 20 32 5F 37 31 72 30 31 20 34
35 31 35 31 38 32 31 00 BB D4

¹Writing "1" sets the Modbus default settings.

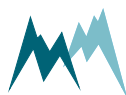

			Example	
	Content	Length (Bytes)	HEX-value	Decimal, ASCII
PDU* response	Slave address	1	23	35
	Function code	1	11	17
	Number of bytes (excl. slave-address, function code, NUL and CRC)	1	26	38
	Slave ID	1	53	"S"
	Run status (0=inactive; FF=active)	1	FF	255
	Modbus implementation version	2	27 74	10100
	Separator	1	20	" "
	Vendor string	7	53 6F 6D 6D 65 72 20	"Sommer "
	Separator	1	20	" "
	Device configuration	7	52 47 2D 33 30 20 20	"RG-30 "
	Separator	1	20	" "
	Software version	7	32 5F 37 31 72 30 31	2_71r01
	Separator	1	20	" "
	Serial number	8	34 35 31 35 31 38 32 31	45151821
	NUL	1	00	
	CRC	2	BB D4	

*Protocol Data Unit

Table 23 Slave ID

12.5.6 How to switch the SQ-R to Sommer bus protocol

Please see the video on the online [Service center](#) for instructions.

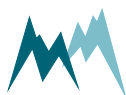

12.5.7 PLC integration

The SQ-R can be integrated into a PLC system as a slave device. It supports the PROFIBUS, PROFINET, EtherCAT and CANopen protocols. This requires an additional serial converter, e.g. Anybus Communicator.

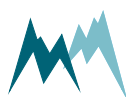

13 Pulse output

13.1 What can I do with it?

The SQ-R sensor provides an impulse output to count the total water discharge. The same output can be used to monitor a limit value. Both options are configured in [DIG OUT](#).

13.2 How to wire pulse output

The SQ-R can send digital impulses proportional to the measured discharge volume to the DIG-OUT port. Connect a data logger with a counter/pulse input as shown in [Figure 24](#) to read the sensor's pulse output.

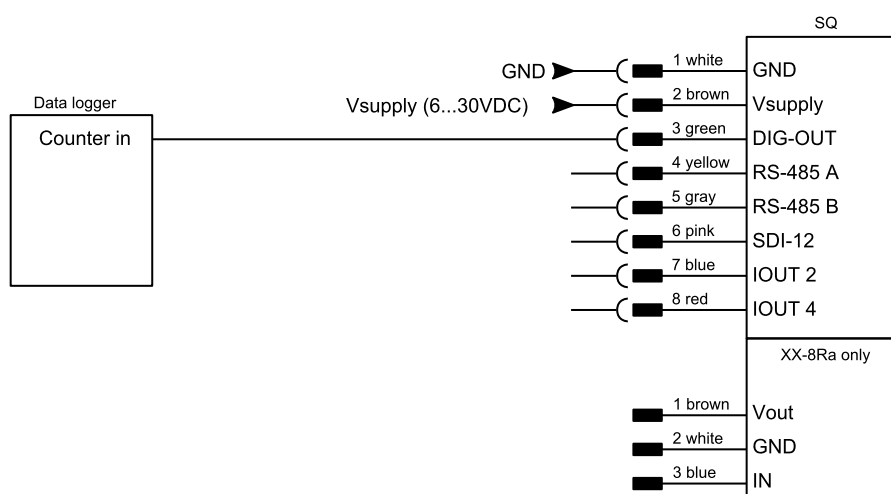

Figure 24 Wiring of the pulse output of the SQ-R

13.3 Configure pulse output

13.3.1 Impulse output for discharge volume

If the digital output is used to count the total water discharge the configuration options must be carefully selected to provide accurate results over a large discharge range.

**ATTENTION**

The selection of the discharge volume per impulse and the impulse width as well as the choice of the discharge units and decimal places strongly affect the time before the total water discharge reaches data overflow.

To select the proper settings for your measurement application we advise to use the function that simulates the impulse output. Please refer to [IO, simulation impulse output](#) for its usage.

The following examples illustrate the selection of the required settings for the impulse output.

**EXAMPLE****Industrial discharge channel**

Assumption:

- Expected discharge rate 100 l/s
- [Measurement Interval](#) 60s

Unit and impulse configuration:

- [IO, discharge volume per impulse](#) 1 m³/impulse
- [IO, impulse width](#) 500 ms
- [Discharge \(Q\), unit](#) l/s, 1 decimal
- [Measurement type](#) m³, 1 decimal

The simulation with the [IO, simulation impulse output](#) function returns:

- 6 Impulses/measurement interval and 8640 m³/day

**EXAMPLE****Irrigation channel, highly fluctuating**

Assumption:

- Expected discharge rate 100 l/s ... 10 m³/s
- [Measurement Interval](#) 300s

Unit and impulse configuration:

- [IO, discharge volume per impulse](#) 10 m³/impulse
- [IO, impulse width](#) 100 ms
- [Discharge \(Q\), unit](#) m³/s, 1 decimals
- [Measurement type](#) m³, 1 decimals

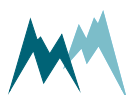



The simulation with the IO, *simulation impulse output* function returns:

- For 100 l/s: 1 Impulse/measurement interval and 8640 m³/day
- For 10 m³/s: 300 impulses/measurement interval and 864000 m³/day

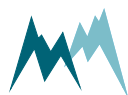

14 Analog output

14.1 What can I do with it?

Measurement values of water level, flow velocity and discharge can be returned by analog 4...20 mA signals. These can be configured in [4-20 mA outputs](#).

14.2 Activation

In the setting [Status](#) the state of the analog output can be set to one of the following options:

ID	Option	Description
1	off (default)	Analog outputs are inactive.
2	just during TRIG	Analog outputs are only active, if an external signal is present at the TRIG input. The outputs are high as long as the signal at the TRIG input is high.
3	always on	Analog outputs are permanently active.



NOTE The SQ-R delays analog data acquisition by 200 ms. If the output is set to *just during TRIG*, the analog output must be read with a delay of min. 200 ms after the trigger has been sent. This ensures that the analog measurement has sufficiently stabilized. As the analog measurement itself requires some time, the result should be read with a delay of *measurement duration + min. 1 second*.

14.3 Scaling

The variables and their analog output range are configured as described below.



NOTE The analog outputs may return currents between 0 and 21 mA. However, the accuracies stated in the specifications are only valid for signals within 4 to 20 mA!

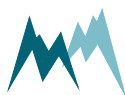



If the measured value falls below or exceeds the 3.9...21 mA range, 3.9 mA and 21 mA, respectively, are returned. An exception are the measurement values 99999998 and 99999997, which return a 3.8-mA and 3.7-mA signal, respectively.



ATTENTION The 4-mA output should correspond to a measurement value at or below the expected minimum! With low current output the accuracy tends to decrease and cross-talk with other analog channels may occur.

14.3.1 IOU2 – water level

The analog output IOU2 returns the water level. The output corresponds to a linear equation defined by the span between 4 and 20 mA and the offset at 4 mA.

By default, **IOU2, level 4-20 mA span** is set to the measurement range of the level sensor. However, the entire range is often not needed and would waste resolution.



EXAMPLE

The Sommer Messtechnik SOMLEVEL-15 is a water level sensor with a measurement range from 0 to 15 m. In a monitoring setup the water level ranges only between 0 and 5m.

Setting **IOU2, level 4-20 mA span** to 15m we would waste 2/3 of the analog output range (left graph). It is more appropriate to set **IOU2, level 4-20 mA span** to 5m, taking advantage of the entire analog output range (right graph).

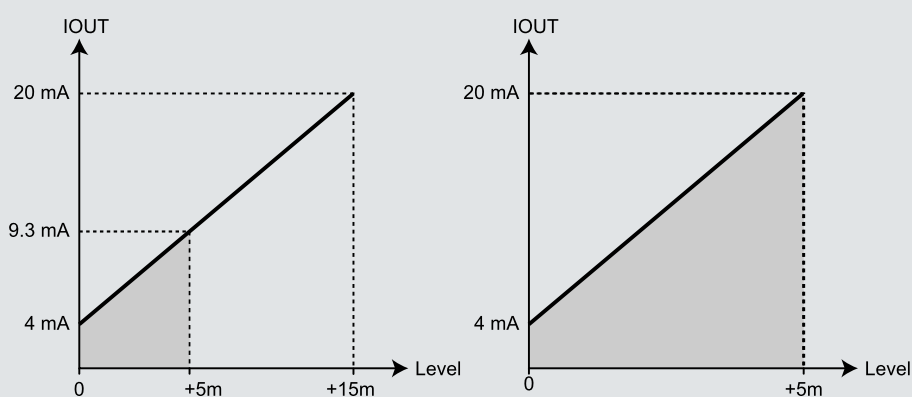



NOTE As water level is defined to be positive, do not use negative numbers for the level span! A negative span denotes the distance between the sensor and the water level and needs to be set carefully.

See the parameter description [IOUT2, level 4-20 mA span](#) for another example.

14.3.2 IOUT4 – flow velocity or discharge

Output IOUT4 is used to return the water flow velocity or water discharge. Only the maximum value of the corresponding option has to be set.

If only uni-directional water flow is allowed (this option is set in [Possible flow directions](#)) the 4 mA signal corresponds to a velocity of 0 m/s and a discharge of 0 m³/s, respectively. If two-directional flow is selected a 12 mA signal corresponds to zero velocity and discharge. In this case the maximum negative velocity/discharge corresponds to 4 mA and the maximum positive velocity/discharge to 20 mA. See [Figure 25](#) for an illustration of these two situations.

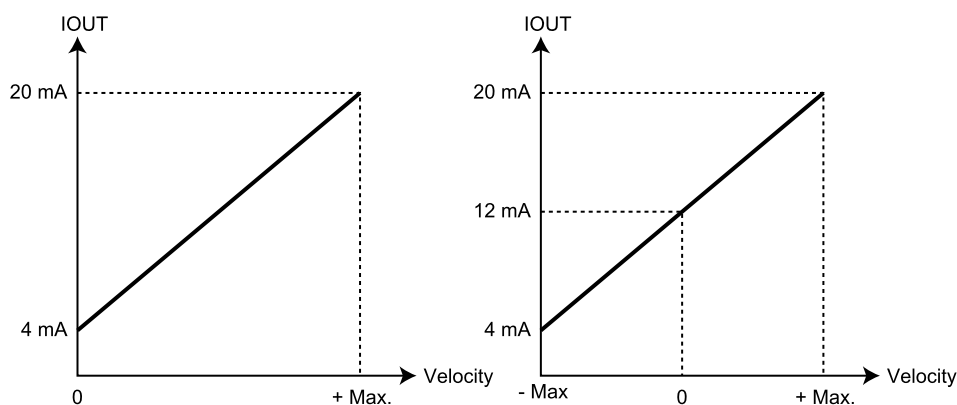

[Figure 25](#) Definition of the 4 to 20 mA signal with uni- and two-directional water flow

14.4 Simulate current output

With this function the analog outputs can be simulated. A user-defined current value between 4 and 20 mA is applied to the analog output pins, which can be read by a connected data acquisition device or multimeter. By pressing Return/Enter again the simulation stops.

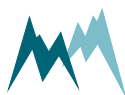

15 Parameter definitions

A	Measurement trigger	104
B	Measurement Interval	104
C	Level (W)	105
D	Velocity	108
E	Discharge table	112
F	DIG OUT	114
G	Technics	120
H	Special functions	146

A Measurement trigger

`generic-measurement-trigger`

Measurements are initiated by one of the options listed in the table below.

The commands to trigger measurements via RS-485 and SDI-12 are described in [Communication](#).

Measured data are either returned directly after the measurement or can be requested by commands via the RS-485 or SDI-12 interface. The format of the returned data can be configured in the sub-menu [Output protocol \(OP\)](#).

ID	Option	Description
1	Interval (default)	Measurements are initiated in a specified interval.
2	TRIG input	Measurements are triggered by the positive edge of a DC-voltage signal applied to the TRIG input (low: 0 ... 0.6 V, high: 2.2 ... 28 V, pulse duration must be ≥ 500 ms, delay between pulses must be ≥ 500 ms)
3	SDI-12/RS-485	Measurements are externally triggered by commands via RS-485 or SDI-12 from ,e.g. a data logger.
4	all allowed	Measurement is triggered by all options mentioned above.

B Measurement Interval

`generic-measurement-interval`

An internal measurement interval can be set for the SQ-R. If selected in menu item [Measurement trigger](#), measurements are performed in the defined interval. However, a measurement is always completed before a new one is initiated.

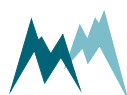

Value range	Default	Units
20...18'000	60	s

C Level (W)

C-A	Mean value, no. of values	105
C-B	Filter, type	106
C-C	Test	106
C-D	Adjustment	106
C-E	W_Q, fixation level	107
C-F	WMA, maximum level	107
C-G	WLL, low level border	107
C-H	WCF, cease to flow level	108
C-I	W-v table reset	108

C-A Mean value, no. of values

rq-discharge-mean-value-no

Every water level measurement is stored internally in a buffer to compute a moving average. This setting defines the number of measurement values in the buffer. If the buffer is full the oldest value is replaced by the most recently recorded value.



ATTENTION If the measurement interval is long, the measurement data may lag behind! For example, if the measurement interval is 5 min and the filter is applied over 10 measurements, it may take up to 50 min until the full scale of a measurement shift is observed.

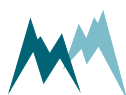
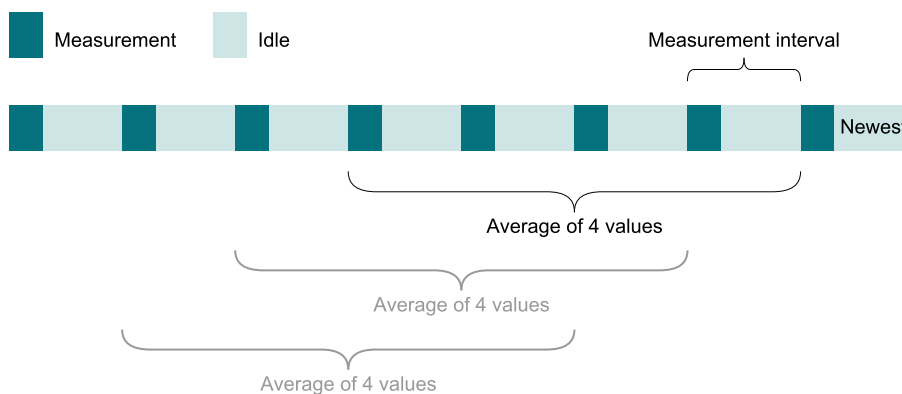

Value range	Default	Units
1...120	1	-

C-B Filter, type

`rq-discharge-filter-type-level`

The water level values in the buffer can be filtered by one of the following options:

ID	Option	Description
1	moving average	The mean value of all buffered values is calculated.
2	elim. pos. spikes	To eliminate positive spikes the mean value is calculated without the 5 highest buffered values. If the buffer size is smaller than 10 half of the values are eliminated.
3	minimum value	The smallest value from the buffer is returned.
4	median value (default)	The median value of the buffered data is returned.
5	elim. neg. spikes	To eliminate negative spikes the mean value is calculated without the 5 lowest buffered values. If the buffer size is smaller than 10 half of the values are eliminated.
6	elim. all spikes	To eliminate positive and negative spikes the mean value is calculated without the 5 highest and 5 lowest buffered values. If the buffer size is smaller than 15 two third of the values are eliminated. Setting C-A needs to be ≥ 3 .

C-C Test

`rq-discharge-test-level`

A level measurement is performed and after completion the result is displayed.

C-D Adjustment

`rq-discharge-adjustment`

Function to adjust the measurement value. First, a measurement is performed and the result displayed. Afterwards, a target value is set and confirmed. The measurement is then adjusted to exactly

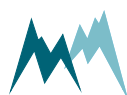

match the target value. The adjustment of the water level measurement is described in detail in Section [Adjustment](#).

C-E W_Q, fixation level

`rq-discharge-fixation-level`

The fixation level W_Q is the vertical distance between the deepest point in the cross-sectional profile and the bottom surface of the SQ-R.



ATTENTION Use the [Adjustment](#) button to set the fixation level W_Q automatically!

Value range	Default	Units
-9999.99...99999.99	0	Unit of level

C-F WMA, maximum level

`rq-discharge-maximum-level`

The maximum possible water level. This value should be smaller as or equal to the fixation level W_Q.



NOTE If set to 0 the machine learning function is deactivated.

Value range	Default	Units
-9999.99...99999.99	0	Unit of level

C-G WLL, low level border

`rq-discharge-low-level-border`

The low level border is the water level below which velocity measurements are not feasible. However, the SQ-R calculates the velocity below WLL with its learning function.

The low level border constitutes the lower limit of the water level range for the calculation of the learning function (continuously updated relation between water level and flow velocity).

Value range	Default	Units
-9999.99...99999.99	0	Unit of level

C-H WCF, cease to flow level

`rq-discharge-cease-to-flow-level`

The cease to flow level is the water level at which there is no water flow in the channel. This may or may not be the river bed (see also [W-v relation](#)).

For water levels between the cease to flow level and the low level border velocities and discharges are extrapolated from the W-v relation. At water levels below WCF no velocities are returned.

Value range	Default	Units
-9999.99...99999.99	0	Unit of level

C-I W-v table reset

`rq-discharge-w-v-table-reset`

The stored W-v table is deleted and the W-v learning starts anew. This is especially required if the water flow regime and thus the W-v relation have changed, e.g. new channel profile.

D Velocity

D-A	Viewing direction	108
D-B	Possible flow directions	109
D-C	River inclination	110
D-D	Yaw angle	110
D-E	Measurement duration	110
D-F	Filter, no. of values	110
D-G	Filter, type	111

D-A Viewing direction

`rq-discharge-viewing-direction`

This setting defines the viewing direction of the SQ-R sensor in relation to the flow direction of the river. The advantages of the different viewing directions are described in [Installation requirements](#).



ID	Option	Description
1	downstream	The SQ-R sensor is directed in flow direction.
2	upstream (default)	The SQ-R sensor is directed against the flow direction.

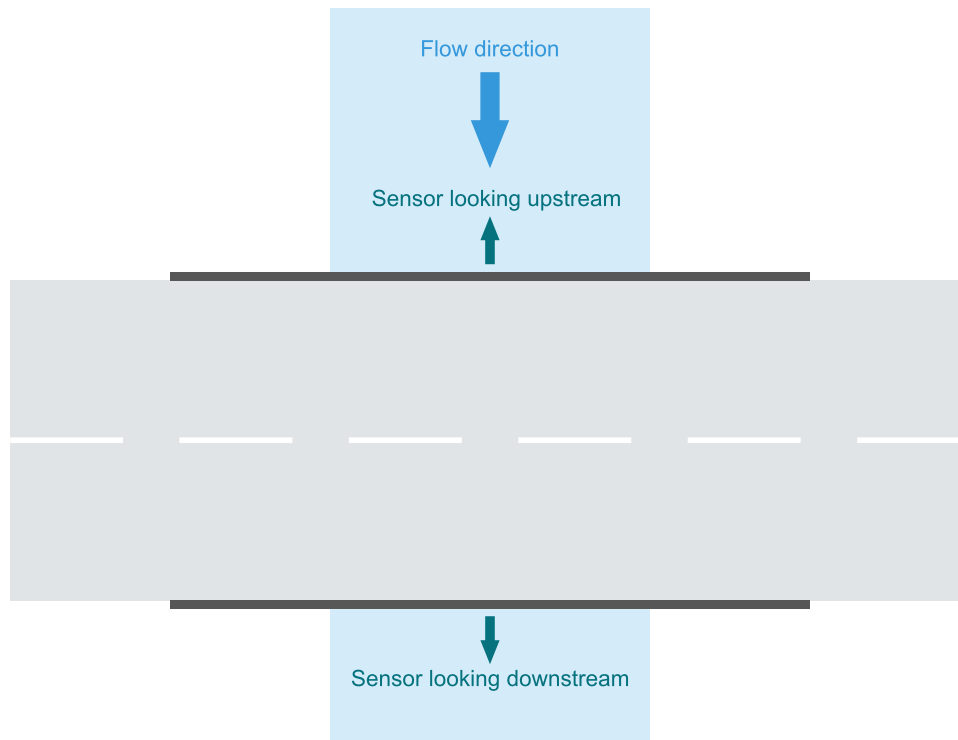

D-B Possible flow directions

`rq-discharge-possible-flow-directions`

Due to the direction separation (see [Flow direction separation](#)) the SQ-R sensor can identify the flow direction. Therefore it has to be defined if the river only flows in one direction or if bi-directional flow can occur as for example under tidal influence.

ID	Option	Description
1	just downstream (default)	Only downstream flow is recorded.
2	two (tide)	Down- and upstream flow is recorded. Upstream flow is indicated by a negative sign.

D-C River inclination

`rq-discharge-river-inclination`

The SQ-R sensor only measures its own vertical inclination. To compensate for the influence of a sloping river surface an additional correction can be set. It is either added or subtracted depending on the flow direction. Generally, rivers do not show an appreciable inclination of the water surface. For the possible flow direction *two (tide)* an inclination of *0* has to be set.

Value range	Default	Units
0...90	0	-

D-D Yaw angle

`rq-discharge-yaw-angle`

Usually the main water flow is perpendicular to the cross Section of a river and the SQ-R sensor is mounted in the same way. However, if the SQ-R sensor has to be rotated horizontally, the rotation angle can be considered for by adjusting this setting. To ensure a reliable and accurate velocity measurement it is recommended to select a yaw angle smaller than 30°.

Value range	Default	Units
0...60	0	Degree

D-E Measurement duration

`rq-discharge-measurement-duration`

The measurement duration defines the duration of a single measurement. During this time the SQ-R signal is recorded and the velocity radar spectrum is analyzed.

Generally, a measurement duration of 30 ... 60 s is recommended. It should be at least 10 s. A long measurement time increases power consumption.

Value range	Default	Units
5...240	30	Seconds

D-F Filter, no. of values

`rq-discharge-filter-values`

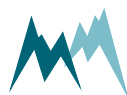

Every velocity measurement is stored internally in a buffer for filtering. This setting defines the number of measurement values in the buffer. If the buffer is full the oldest value is replaced by the most recently recorded value.

The number of buffered values depends on the turbulence of the water surface. Highly turbulent rivers demand a small buffer, rivers or irrigation channels with low turbulence require a larger buffer.

 **ATTENTION** If the measurement interval is long, the measurement data may lag behind! For example, if the measurement interval is 5 min and the filter is applied over 10 measurements, it may take up to 50 min until the full scale of a measurement shift is observed.

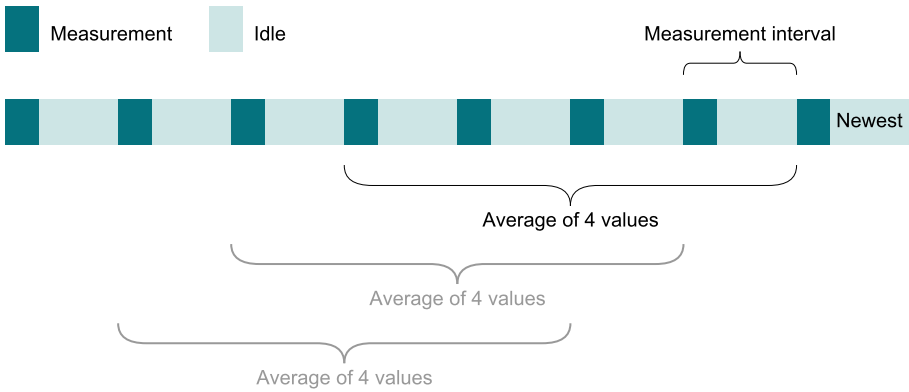

Value range	Default	Units
1...120	1	-

D-G Filter, type

`rq-discharge-filter-type-velocity`

The velocity values in the buffer can be filtered by one of the following options:

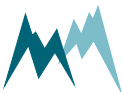

ID	Option	Description
1	moving average (default)	The mean value of all buffered values is calculated.
2	eliminate spikes	To eliminate spikes the mean value is calculated without the 5 highest and 5 lowest buffered values. If the buffer size is smaller than 15 two third of the values are eliminated.
3	minimum value	The smallest value from the buffer is returned.
4	median value	The median value of the buffered data is returned.

E Discharge table

`rq-discharge-table`

As described in Section [Determination of water discharge](#) the discharge is calculated from the measured water level and the measured velocity considering the cross-Sectional area and the k-factors. The values of the cross-Sectional areas and the k-factors are set in the discharge table.

The information is arranged in 16 lines ordered from low to high water levels. The values for water levels between two lines are interpolated linearly.

The discharge table can be generated with the software SQ-Commander of Sommer GmbH. This program calculates areas and k-factors from a cross-Sectional profile and additional characteristics of the water channel. It also provides functionality to transfer the discharge table to the memory of the SQ-R sensor. See Sections [Determination of water discharge](#) and [Performing a site survey](#) for more details on discharge tables and their generation.

	Status	Level (W)	K value	Area (A)
		[m]	[]	[m ²]
01	on	0.4	64.0	4.7
02	on	0.6	68.7	9.5
03	on	0.8	72.1	14.4
04 ... 14
15	on	4.9	79.5	141.8
16	on	6.7	80.7	202.4

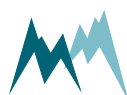

E-A Status

rq-discharge-status-discharge-table

The status describes the activity and priority of a data line within the discharge table. The following options are available:

ID	Option	Description
1	Off (default)	The line is inactive.
2	theor.	The line is active with theoretical values from a numerical hydraulic model.
3	calib.	The line is active with calibrated values from a reference measurement. These values have high priority.

E-B Level (W)

rq-discharge-level

The entries of the discharge table are ordered from low to high water levels. The unit of the water level is defined in the submenu [Units and decimals](#).

Value range	Default	Units
-9999.99...99999.99	0	Unit of level

E-C k value

rq-discharge-k-value

The k-factor is the ratio between the mean and the measured local velocities at the defined water level (see [k-Factors](#)). The value is scaled to 1, i.e. a k-factor of 70 % is entered as 0.700.

Value range	Default	Units
0...99999.999	1	-

E-D Area (A)

rq-discharge-area

The area is the cross-Sectional area of the water filled part of the river or flow channel.

Value range	Default	Units
-9999.99...999999.99	0	Unit of area

F DIG OUT

F-A	DIG-OUT Function	114
F-B	IO, discharge volume per impulse	114
F-C	IO, impulse width	115
F-D	IO, simulation impulse output	116
F-E	LM, trigger via	118
F-F	LM, limit type	118
F-G	LM, limit value	119
F-H	LM, hysteresis	119

F-A DIG-OUT Function

`rq-pulse-out-dig-out-function`

With this parameter the function of the digital output can be selected:

ID	Option	Description
1	limit monitor (LM)	If the limit value (set in LM, limit type and LM, limit value) is violated a single voltage impulse is returned.
2	Impulse output (IO) (default)	Voltage impulses are returned relative to the measured discharge volume. The discharge volume per impulse is set in IO, discharge volume per impulse .

F-B IO, discharge volume per impulse

`rq-pulse-out-io-discharge-volume-per-impulse`

This parameter defines the discharge volume of a measurement interval per impulse. The unit corresponds to the unit of the total discharge set in [Total discharge volume unit*](#).

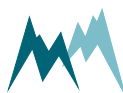

ID	Option	Description
1	0.1 */imp	* ... unit assigned to the discharge
2	1 */imp	* ... unit assigned to the discharge
3	10 */imp (default)	* ... unit assigned to the discharge
4	100 */imp	* ... unit assigned to the discharge
5	1000 */imp	* ... unit assigned to the discharge



EXAMPLE The discharge unit is set to *l/s*, the measurement interval is 60 seconds and the measured discharge rate shall be *50 l/s*. The discharge volume per impulse is set to *100 */imp*, meaning that a single impulse represents 100 liters. At a constant discharge rate of 50 l/s a total discharge volume of 50 l/s x 60 s equals 3000 l / 60 s. The resulting output will thus be 3000 l / 100 l = 30 impulses.



ATTENTION If the time to return the impulses would take longer than the measurement interval, use this parameter to increase the amount of discharge volume represented by a single impulse.



ATTENTION In case the highest setting (*1000 */imp*) is not sufficient, Sommer suggests changing the device' total discharge volume unit to a bigger volume unit, e.g. from *litres/s* to *m³/s* (see [Total discharge volume unit*](#)). You can check if the chosen settings fit your requirements by running the function [Simulation, discharge volume](#).



ATTENTION If the discharge volume per impulse is set to *0.1 */imp* the number of decimal digits defined for the total discharge must be set to 1 (see [Total discharge volume decimal](#)). Otherwise, the digits are automatically adjusted and the warning message *Parameter conflict (view manual)! (0001)* is displayed.

F-C IO, impulse width

rq-pulse-out-io-impulse-width

Impulse width defines the duration of the voltage impulse and can take the following values:

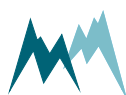

ID	Option	Description
1	500 ms (default)	The impulse duration is 500ms
2	100 ms	The impulse duration is 100ms
3	30 ms	The impulse duration is 30ms

The lower the impulse duration the shorter the required amount of time to output all impulses.



ATTENTION If the time to return the impulses would take longer than the measurement interval, the internal counter is automatically reset to 0 and an error message is displayed (Error code 0008). Do not use this parameter to decrease the amount of time required for recording the result. Instead, adjust [IO, discharge volume per impulse](#).

F-D IO, simulation impulse output

rq-pulse-out-io-simulation-impulse-output

With this function a user defined discharge volume and its resulting impulse count can be simulated. This simulation is based on the settings in menus [DIG OUT](#) and [Units and decimals](#).



EXAMPLE

The following SQ-R settings are assumed:

[Measurement trigger](#) internal

[Measurement Interval](#) 60 s

[DIG-OUT Function](#) impulse output (IO)

[IO, discharge volume per impulse](#) 10 */imp

[IO, impulse width](#) 500 ms (corresponds to 1 impulse per second)

[Discharge \(Q\), unit](#) l/s

[Discharge \(Q\) decimals](#) 1

[Total discharge volume unit*](#) m³

[Total discharge volume decimal](#) 1

After pressing the button in SQ-Commander a window will pop up:

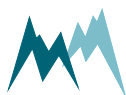



Test mode

Perform command
Execute command

```
#M0001G02se07 0.000|0899999998|09 574|10 10.32|3A6B;
#M0001G01se0199999998|02 0.904|03 0.325|04 -20.89|05 2938.0|06 1160.5|B2F6;
#M0001G02se07 0.000|08 0.0|09 560|10 10.33|611C;
#A0001ok_bq|6FE5;
#A0001FD> M:0x00D0|FBF8;
```

IO, simulation impulse output
^^

Maximum discharge: 9999.9 l/s
Minimum discharge (suggestion): 166.7 l/s

PLEASE NOTE: DIG-OUT setting determines maximum discharge!
PLEASE NOTE: If limits are not ok, please view manual to adjust settings properly!

Desired simulation discharge in l/s: |
10/12
Waiting time: 98/120 s

Cancel

Notice: Simulated minimum and maximum discharges are dependent on the settings in DIG-OUT output and Units and decimals. Furthermore, the SQ-R sensor provides 8 characters to display the total daily discharge. Thus, the maximum discharge rate is restricted either by the total daily discharge – in the current example *999'999.9 m3* – or by the selected impulse count. In the current example the impulse width is set to 500 ms, which corresponds to 1 impulse recorded per second. With a discharge volume of *10 m3/impulse* this corresponds to 10 m3/s (9'999.9 l/s) or 864'000.0 m3/d, which is below the maximum daily discharge.

The minimum discharge is based on the idea that the SQ-R sensor records one impulse per measurement interval. In the current example 1 impulse equals 10 m3. With a measurement interval of 60 s this corresponds to 166.7 l/s.

Enter the discharge rate you want to simulate, e.g. *1'000 l/s*, and press **Enter**. The result lists the impulse count and discharge volume per measurement:



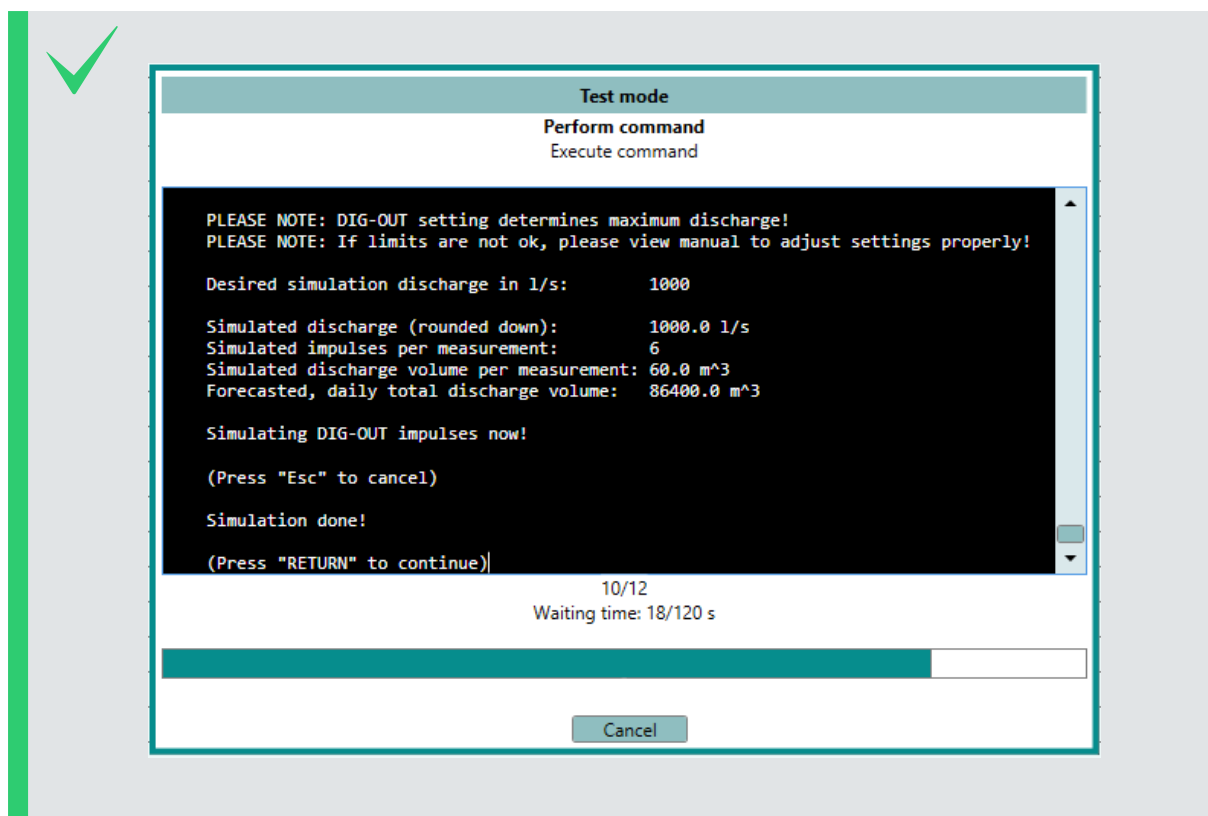

F-E LM, trigger via

rq-discharge-lm-trigger-via

This parameter defines the method by which the discharge is monitored. One of the following options can be selected:

ID	Option	Description
1	Off (default)	Surveillance deactivated
2	discharge	Surveillance of the discharge of the device
3	multi-point discharge	Same as option discharge
4	level	Surveillance of the level
5	velocity	Surveillance of the velocity
6	AUX	Surveillance of the AUX input

F-F LM, limit type

rq-discharge-lm-limit-type



This parameter defines the orientation of the threshold. The following options are available:

ID	Option	Description
1	limit overrun (default)	Violation when the defined value exceeds the limit
2	limit underrun	Violation when the defined value drops below the limit

F-G LM, limit value

`rq-discharge-lm-limit-value`

This parameter specifies the magnitude of the limit value.

Value range	Default	Units
-99999.99...999999.99	0	Unit of selected parameter (level, velocity,...)

F-H LM, hysteresis

`rq-discharge-lm-hysteresis`

The specification of a hysteresis value suppresses multiple violations if the measurement value closely fluctuates around the threshold. After a violation the hysteresis value has to be exceeded to cause a new violation. The hysteresis is an absolute value and is added with the correct sign to the threshold. [Figure 26](#) illustrates an example.

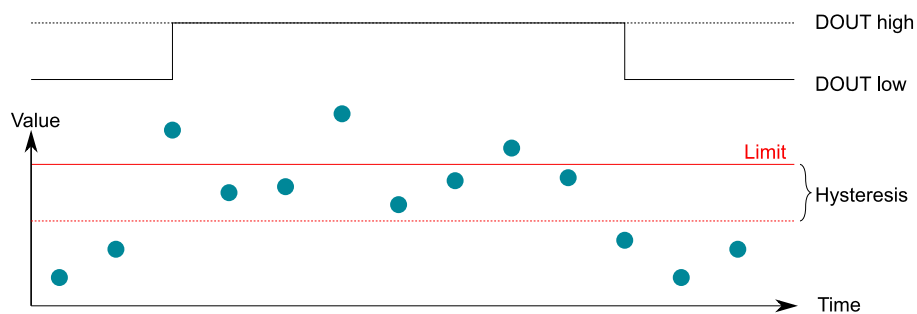

Figure 26 Hysteresis in monitoring of water level W

Value range	Default	Units
0...999999.99	0	Unit of selected parameter (level, velocity,...)

G Technics

G-A	Language/Sprache	120
G-B	Decimal character	120
G-C	SDI-12 address	121
G-D	Channel type	121
G-E	W-v priority	121
G-F	Area correction	122
G-G	Advanced settings	122
G-H	Tech. level (W)	124
G-I	Tech. velocity (v)	125
G-J	4-20 mA outputs	131
G-K	RS-485 Protocol	133
G-L	RS-485 Port	136
G-M	Units and decimals	139

G-A Language/Sprache

`generic-language`

The menu language.

ID	Option	Description
1	German/Deutsch	German language
2	English/Englisch (default)	English language

G-B Decimal character

`generic-decimals-character`

The character used as decimal separator in the values of the settings, in serial data strings and in .csv files.

ID	Option	Description
1	Comma	-
2	Dot (default)	-

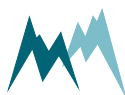

G-C SDI-12 address

generic-sdi-12-address

The address is a unique identifier of the sensor within a SDI-12 bus system.

Value range	Default	Units
0...9, a...z, A...Z	0	-

G-D Channel type

rq-discharge-channel-type

This parameter specifies the type of flow channel where the SQ-R sensor is installed. The selection determines how the flow velocity is calculated from the velocity spectrum (see [Channel type](#) for details). One of the following options can be selected:

ID	Option	Description
1	open (default)	Open flow channel.
2	covered	Closed or covered flow channel, e.g. discharge pipe.

G-E W-v priority

rq-discharge-w-v-priority

The W-v priority determines if the measured or learned values of the velocity and discharge are returned (see [W-v priority](#)).



ATTENTION For water levels below the low level border WLL the learned velocity and discharge are returned.

ID	Option	Description
1	no (default)	The measured velocity and discharge are returned as part of the main values. The learned velocity and discharge are returned as part of the special values.
2	yes	The learned velocity and discharge are returned as part of the main values. The measured velocity and discharge are returned as part of the special values.

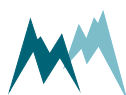

G-F Area correction

`rq-discharge-area-correction`

In case of small changes of the river bed, and consequently the cross-sectional area, the discharge table can be adjusted by an offset. It is recommended to avoid larger corrections with this parameter.

Value range	Default	Units
-99999.99...999999.99	0	Unit of area

G-G Advanced settings

G-G-A	Reset general behavior	122
G-G-B	Reset total discharge volume	122
G-G-C	Inclination measurement	123
G-G-D	Sleep mode	123
G-G-E	Sommer ID	124

G-G-A Reset general behavior

`generic-reset-behavior`

The SQ-R keeps certain sensor data in its memory, e.g. the measured data for calculation of the moving average. This setting defines whether the acquired sensor data are deleted upon a sensor reset or not.

ID	Option	Description
1	hard reset	A reset deletes all acquired and stored sensor data.
2	soft reset (default)	All acquired and stored sensor data are kept for measurements and calculations.



NOTE During the installation a hard reset is recommended. After finishing the installation a soft reset should be selected. This shortens start-up time.

G-G-B Reset total discharge volume

`rq-discharge-reset-total-discharge`

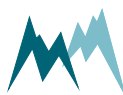

The value of the total discharge volume when the SQ-R is restarted (either by re-powering the SQ-R or by the function [Relaunch program](#)). By interrupting the power supply of the SQ-R this function can be used to reset the total discharge volume in a specified interval.

ID	Option	Description
1	hold value (default)	The last value of the total discharge is set.
2	set to zero	The total discharge is set to zero.

G-G-C Inclination measurement

rq-discharge-inclination-measurement

The measurement of the flow velocity has to be corrected for the inclination of the SQ-R sensor as described in [Inclination angle measurement](#). The following angle corrections are available:

ID	Option	Description
1	first measurement (default)	The inclination is only measured prior to the first measurement after the initialization process (after powering up and after parameter updates)
2	every measurement	The inclination is measured during each velocity measurement.



ATTENTION If the inclination of the SQ-R sensor can change, i.e. if mounted on a cable way, the inclination should be measured along each velocity measurement.

G-G-D Sleep mode

generic-sleep-mode

Defines the behavior of the SQ-R between two measurements, provided the measurement interval is longer than the time of the measurement itself. The following options are available:

ID	Option	Description
1	MODBUS, fast	For MODBUS applications. The SQ-R stays in normal mode. This option permits high data transmission rates, but increases power consumption.
2	MODBUS, slow	For MODBUS applications. The SQ-R goes into idle mode and can be woken up by a command via the RS-485 interface with a low baud rate. This option reduces power consumption at lower data transmission rates.
3	Standard (default)	The SQ-R goes into sleep mode and can be woken up by a command via the RS-485 interface only with a time delay. Option with the lowest power consumption.

G-G-E Sommer ID

`generic-sommer-id`

The Sommer ID is used to define stations within the SQ-Commander software. The ID is preset in the device and corresponds to its serial number. SOMMER suggests not to change the ID, except if a SQ-R device is replaced. In such a case it can be practical to change the ID of the new device to the ID of the replaced device to guarantee data consistency.

G-H Tech. level (W)

This submenu contains the technical parameters for the water level measurement.

G-H-A	Supply	124
G-H-B	Warm-up time	125
G-H-C	Measurements per cycle	125

G-H-A Supply

`rq-discharge-supply`

For an efficient energy management the power supply mode of the water level sensor can be set to one of the following options:

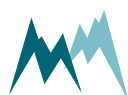

ID	Option	Description
1	switched	Sensor power supply is only switched on for measurements.
2	always on (default)	Sensor power supply is always on.
3	always off	Sensor power supply is always off.  ATTENTION This option deactivates the level sensor! Only use it if the level sensor is supplied by an external power source!

G-H-B Warm-up time

`rq-discharge-warm-up-time`

The time between power-up of the sensor and the first measurement. The water level sensor requires 60 s before valid measurements are returned. Thus, for the switched power supply mode the warm-up time has to be at least 60 seconds.

The figure below illustrates the measurement sequence of the SQ-R including the warm-up time of the level sensor.

Value range	Default	Units
0...255	30	Seconds

G-H-C Measurements per cycle

`rq-discharge-measurements-per-cycle`

Level measurements are performed in the configured measurement interval or upon an external trigger command (RS485 or SDI-12). However, more accurate results can be attained if the measurements per cycle are increased. By setting this parameter to e.g. 3, three level measurements are performed in quick succession.

Value range	Default	Units
1...50	9	-

G-I Tech. velocity (v)

This submenu contains the technical parameters for the velocity measurement.

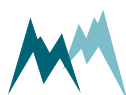

G-I-A	Minimum velocity	126
G-I-B	Maximum velocity	126
G-I-C	Meas. spot optimization	126
G-I-D	Measurement type	127
G-I-E	Stop, min. quality (SNR)	128
G-I-F	Stop, max. opp. direction	129
G-I-G	Stop, number of valid meas.	129
G-I-H	Stop, behavior	129
G-I-I	Stop, replace value	130
G-I-J	Stop velocity at WLL	130
G-I-K	Meas. spot weighting	131

G-I-A Minimum velocity

`rq-discharge-minimum-velocity`

The minimum velocity defines the lower limit for the velocity determination by spectral analysis.

Value range	Default	Units
0...1.5	0.08	m/s

G-I-B Maximum velocity

`rq-discharge-maximum-velocity`

The maximum velocity defines the upper limit of expected velocities. The velocity measurement is optimized for this setting. Usually a value of 5000 mm/s (5 m/s) is adequate. No extra margin has to be accounted for as this is included in the SQ-R sensor by default.

Value range	Default	Units
0...15	5	m/s

G-I-C Meas. spot optimization

`rq-discharge-meas-spot-optimization`

Inactive if parameter Channel type [Channel type](#) is set to covered.

This parameter describes the expected flow velocity distribution within the measurement spot as illustrated in [Figure 27](#). For a more heterogeneous flow distribution a wider spectral band width has to be selected. The options are as follows:

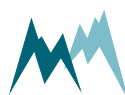

ID	Option	Description
1	very constant veloc.	homogenous water surface, small bandwidth
2	standard (default)	heterogeneous water surface, wide bandwidth
3	bank area	heterogeneous water surface with very different velocities, very wide bandwidth
4	splash water	Splashing water surface, full bandwidth

For the initial measurements at a new site the option *standard* is recommended. Later on the measurement may be improved by selecting another optimization option.

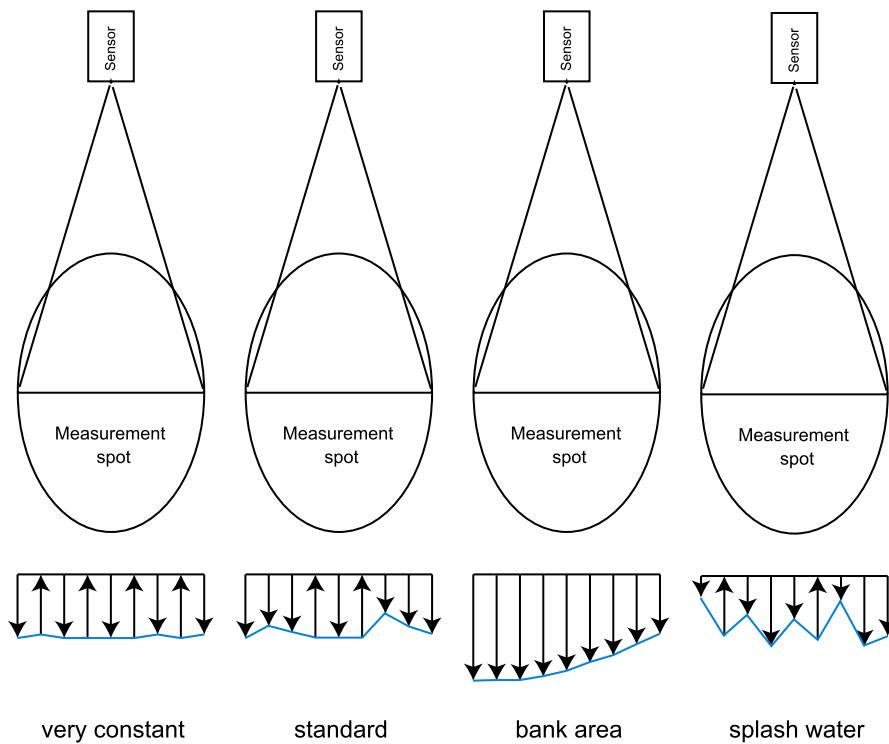
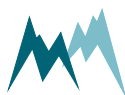

Figure 27 Measurement spot optimization concepts

G-I-D Measurement type

`rq-discharge-measurement-type`

The flow velocity can be measured by two different methods:



ID	Option	Description
1	continuous (default)	The measurement is performed in one piece.
2	sequenced	The measurement is split into five parts.

Continuous measurement type

The flow velocity measurement is performed continuously in one piece. This has the advantage of a fast measurement with little energy consumption. However, for highly fluctuating velocities the measurement time has to be increased considerably to gain accurate results.

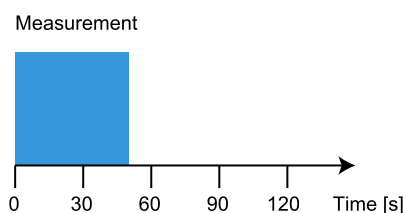

Figure 28 Continuous measurement type

Sequenced measurement type

The flow velocity measurement is divided into five sub-intervals of random length summing up to the specified measurement duration. This increases the complete measurement duration without increasing energy consumption. Thus, this method provides more accurate results for highly fluctuating velocities.

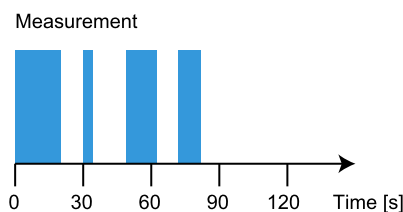

Figure 29 Sequenced measurement type

G-I-E Stop, min. quality (SNR)

`rq-discharge-stop-min-quality`

This parameter defines the lower limit of the quality value, expressed by SNR. Flow velocities below this quality value are identified as invalid. Invalid measurements are handled according to the behavior set in [Stop, behavior](#).

A measurement with a low SNR occurs if the velocity is below the detection limit. It is recommended to set this parameter at measurement sites with tidal influence or with back-water and where the velocity can drop to zero.

Value range	Default	Units
7...100	30	-

G-I-F Stop, max. opp. direction

`rq-discharge-stop-max-opp-direction`

The opposite direction content is the fraction of counter-flow in measurement direction. The parameter defines an upper limit for counter-flow, above which measurements are identified as invalid. Invalid measurements are handled according to the behavior set in [Stop, behavior](#).

Value range	Default	Units
10...1000	200	%

G-I-G Stop, number of valid meas.

`rq-discharge-stop-number-valid-meas`

After an invalid measurement has occurred the selected number of valid measurements has to be returned before the measurements are tagged as valid again.

Value range	Default	Units
1...20	3	-

G-I-H Stop, behavior

`rq-discharge-stop-behaviour`

This parameter defines the handling of invalid measurements. The following options can be set:

ID	Option	Description
1	hold value	The last valid value is returned.

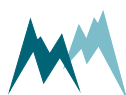

ID	Option	Description
2	use replace value (default)	The replacement value set in Stop, replace value is returned.
3	use learn value	The learned value according to the water level of the W-v relation is returned.

**NOTE**

The option *use learn value* should only be used after the SQ-R has gained a w-v learning curve over a wide range of water levels. Depending on the dynamic of the river or channel this may take days to months. If the covered range is very small, the SQ-R may not be able to compute a learned value.

Use the option *hold value* only if are confident that it reasonably approximates the true flow!

When starting measurements at a new site it is recommended to use the option *replace value* with a distinct value, e.g. *-999*. This enables you to detect any unexpected conditions or behaviors of the flow regime or the setup.

**NOTE**

If **Stop, behavior** is set to *use learn value* and the W-v table has no or only one entry, the **Stop, replace value** will be returned. This can be the case for a newly installed SQ-R that has gained velocity data for a narrow water level range only.

G-I-I Stop, replace value

`rq-discharge-stop-replace-value`

An invalid measurement is replaced by this value if option 2 in **Stop, behavior** is selected.

Value range	Default	Units
-9.999...9.999	0	m/s

G-I-J Stop velocity at WLL

`rq-discharge-stop-velocity-wll`

If the water level during installation is between the low level border WLL and the flow stop level WCF), the flow velocity can be set with this parameter in order to instantly record discharge values. As soon as the water level is above the low level border WLL this parameter is not relevant any more.

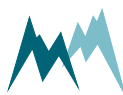

Value range	Default	Units
-9.999...9.999	0	m/s

G-I-K Meas. spot weighting

`rq-discharge-meas-spot-weighting`

Weighting factor used to adjust the flow velocity measurement to specific wave characteristics. For most applications the default of zero is applicable. Positive values reduce the flow velocity, negative values increase the velocity. For a river with a rough water surface, a value of 17 may be applied.

Value range	Default	Units
-100...100	0	-

G-J 4-20 mA outputs

G-J-A	Status	131
G-J-B	IOUT2, level 4-20 mA span	132
G-J-C	IOUT2, level 4 mA value	132
G-J-D	IOUT4, max. discharge	132
G-J-E	IOUT4, max. velocity	133
G-J-F	Simulate current output	133

G-J-A Status

`generic-analog-out-status`

The status defines the behavior of the analog outputs.

ID	Option	Description
1	off (default)	Analog outputs are inactive.
2	just during TRIG	Analog outputs are only active, if an external signal is present at the TRIG input. The outputs are high as long as the signal at the TRIG input is high.
3	always on	Analog outputs are permanently active.

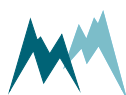

G-J-B IOOUT2, level 4-20 mA span

rq-analog-out-iout2-level-span

The output range of the 4-20 mA signal for the water level. The span should cover the complete water level range that is expected.

Value range	Default	Units
-9999999...99999999	8000	mm

**EXAMPLE**

Minimum expected water level: 120 mm

Maximum expected water level: 1450 mm

Water level span: 1330 mm

IOOUT2, level 4-20 mA span: 1600 (a change of 100 mm corresponds to a change of 1 mA)

IOOUT2, level 4 mA value: 0

In some cases it may be required to report the distance to the water surface instead of the water level. This can be achieved with the following settings:

IOOUT2, level 4-20 mA span: -1600 mm

IOOUT2, level 4 mA value: 1600 mm

G-J-C IOOUT2, level 4 mA value

rq-analog-out-iout2-level-4ma-value

This minimum water level that corresponds to the 4 mA current output. The value should be below the lowest expected water level and should be easily interpretable.

Value range	Default	Units
-99999.99...999999.99	0	Unit of water level

G-J-D IOOUT4, max. discharge

rq-analog-out-iout4-max-discharge

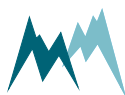

This maximum discharge that corresponds to the 20 mA current output. The 4 mA output is predefined to correspond to a discharge of 0.

Value range	Default	Units
-99999.99...999999.99	100	Unit of discharge

G-J-E IOU4, max. velocity

`rq-analog-out-iout4-max-velocity`

This value defines the maximum flow velocity that corresponds to the 20 mA current output. The 4 mA output is predefined to correspond to a velocity of 0.

Value range	Default	Units
-99999.99...999999.99	5	Unit of velocity

G-J-F Simulate current output

`generic-analog-out-simulate-current`

With this function the analog outputs can be simulated. Upon submission of a current value between 4 and 20 mA the corresponding values of the selected variable are displayed. The selected current is also applied to the active analog outputs and can be read with a connected data logger or multimeter. By pressing Return/Enter again the simulation stops.



NOTE

If **Status** is deactivated, no current output can be simulated.
 If **Status** is set to **just during TRIG**, the trigger must be set prior to simulation. Additionally, the trigger must be reset before each simulation.

G-K RS-485 Protocol

G-K-A	Device number	134
G-K-B	System key	134
G-K-C	Measurement output	134
G-K-D	Information	134
G-K-E	Wake-up sequence	135
G-K-F	Prefix holdback	135
G-K-G	MODBUS, set default	136
G-K-H	MODBUS, device address	136

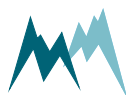

G-K-A Device number

`generic-rs-485-protocol-device-number`

The device number is used for the unique identification of the device in a bus system.

Value range	Default	Units
0...98	1 (default)	-

G-K-B System key

`generic-rs-485-protocol-system-key`

The system key defines the bus system of the device. Thus, different conceptual bus systems can be separated. Interfering bus systems occur if the remote radio coverage of two measurement systems overlap. In general, the system key should be set to 00.

Value range	Default	Units
0...99	0	-

G-K-C Measurement output

`generic-rs-485-protocol-measurement-output`

Specifies the timing of the serial data output.

ID	Option	Description
1	Just per command	The output is only requested by commands via RS-485.
2	After measurement (default)	The serial data output is performed automatically right after each measurement.
3	Pos. TRIG slope	The output is triggered by a positive edge of a control signal applied to the trigger input.

G-K-D Information

`generic-rs-485-protocol-information`



The main measurement values are always included in the data output string. Additionally, special and analysis values can be included.

ID	Option	Description
1	Main values	Only the main values are returned.
2	& Special values (default)	Main values and special values are returned.
3	& Analysis values	Main, special and analysis values are returned.

G-K-E Wake-up sequence

`generic-rs-485-protocol-wake-up-sequence`

Serial data can be transmitted to a recording device automatically without a request. However, many devices demand a wake-up sequence before they can receive and process data. The SQ-R has the option to send a sync sequence and a prefix before data are transmitted (see [Waking-up a connected data logger](#)). The following options are available:

ID	Option	Description
1	Off	No wake-up sequence
2	Sync	The sync sequence UU~?~? is sent before the output string.
3	Prefix (default)	A blank with a time delay is sent before the output string.
4	Prefix & Sync	A blank with a time delay and the sync sequence UU~?~? is sent before the output string.

G-K-F Prefix holdback

`generic-rs-485-protocol-prefix-holdback`

The hold-back time defines the time delay between the prefix and the data string.

Value range	Default	Units
0...5'000	300	ms



G-K-G MODBUS, set default

generic-rs-485-protocol-modbus-set-default

Sets all parameters required for Modbus communication automatically. The following settings are adapted:

Parameter	Modbus setting
OP, measurement output	just per command
Output protocol (OP)	Modbus
MODBUS, device address	35
Sleep mode	Modbus, slow
Parity, stop bits	even par, 1 stop
Baud rate	19200
Flow control	off
Transmitter warm-up time	10 ms
Minimum response time	30 ms

G-K-H MODBUS, device address

generic-rs-485-protocol-modbus-device-address

Unique device address for the Modbus protocol.

Value range	Default	Units
1...247	35	-

G-L RS-485 Port

G-L-A	Baud rate	136
G-L-B	Parity, stop bits	137
G-L-C	Minimum response time	137
G-L-D	Transmitter warm-up time	138
G-L-E	Flow control	138
G-L-F	Sending window	138
G-L-G	Receiving window	138

G-L-A Baud rate

generic-rs-485-port-baud-rate

The following transmission rates in bps (baud) can be selected:

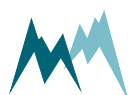

ID	Option	Description
1	1'200	-
2	2'400	-
3	4'800	-
4	9'600 (default for sensors and data logger inputs)	-
5	19'200 (default if used with radio communication)	-
6	38'400	-
7	57'600	-
8	115'200 (default for data loggers)	-

G-L-B Parity, stop bits

`generic-rs-485-port-parity-stop-bits`

The following combinations of parity and stop bits can be selected:

ID	Option	Description
1	No par, 1 stop (default)	No parity and 1 stop bit
2	No par, 2 stop	No parity and 2 stop bits
3	Even par, 1 stop	Even parity and 1 stop bit
4	Odd par, 1 stop	Odd parity and 1 stop bit

G-L-C Minimum response time

`generic-rs-485-port-minimum-response-time`

This setting avoids failures of half-duplex interfaces. For this purpose the response to a command is delayed by the selected time. Additionally, the response is also kept temporally compact.

Value range	Default	Units
0...2'000	0	ms

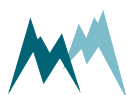

G-L-D Transmitter warm-up time

generic-rs-485-port-transmitter-warm-up-time

The transmitter warm-up time defines the time before data is sent.

Value range	Default	Units
0...2'000	10	ms

G-L-E Flow control

generic-rs-485-port-flow-control

Flow control for the defined application.

ID	Option	Description
1	Off	no flow control
2	XOFF-XON blocking (default)	XOFF-XON flow control, especially adapted for half-duplex systems



ATTENTION To use spectrum mode ([View spectral distribution](#)) set [Flow control](#) to *XOFF-XON blocking*. This enables a return to normal mode at any time.

G-L-F Sending window

generic-rs-485-port-sending-window

If XON-XOFF flow control is activated data are transmitted in blocks with the defined length.

Value range	Default	Units
200...5'000	300	ms

G-L-G Receiving window

generic-rs-485-port-receiving-window

If XON-XOFF flow control is activated transmission of blocks is delayed by the specified time.

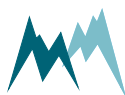

Value range	Default	Units
200...5'000	300	ms

G-M Units and decimals

G-M-A	Level, unit	139
G-M-B	Level, decimals	139
G-M-C	Velocity, unit	140
G-M-D	Velocity decimals	140
G-M-E	Discharge (Q), unit	140
G-M-F	Discharge (Q) decimals	141
G-M-G	Total discharge volume unit*	141
G-M-H	Total discharge volume decimal	142
G-M-I	Simulation, discharge volume	142
G-M-J	Area (A), unit	145
G-M-K	Area (A) decimals	145

G-M-A Level, unit

generic-units-level

The following units of the level/distance can be selected:

ID	Option	Description
1	mm (default)	Millimeter
2	cm	Centimeter
3	m	Meter
4	in	Inch
5	ft	Feet
6	yd	Yard

G-M-B Level, decimals

generic-decimals-level

The number of decimal places for the measured level/distance.

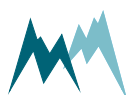

Value range	Default	Units
0...6	0	-

G-M-C Velocity, unit

`generic-units-velocity`

The following units of the flow velocity can be selected:

ID	Option	Description
1	mm/s	Millimeter per second
2	m/s (default)	Meter per second
3	km/h	Kilometer per hour
4	ft/s	Feet per second
5	in/s	Inch per second
6	mph	Miles per hour
7	kn	Knots

G-M-D Velocity decimals

`generic-decimals-velocity`

The number of decimal places for the measured velocity.

Value range	Default	Units
0...6	2	-

G-M-E Discharge (Q), unit

`generic-units-discharge`

The following units of the water discharge can be selected:

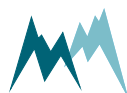

ID	Option	Description
1	l/s	Liter per second
2	m ³ /s (default)	Cubic meter per second
3	ft ³ /s	Cubic feet per second
4	ac-ft/h	Acre-feet per hour
5	us. gal/s	US gallons per second
6	en. gal/s	English gallons per second
7	MI/d	Megaliter per day
8	m ³ /h	Cubic meter per hour



ATTENTION When the discharge unit is changed the internal discharge volume counter is reset to 0!

G-M-F Discharge (Q) decimals

generic-decimals-discharge

This parameter sets the number of decimal places for the water discharge.

Value range	Default	Units
0...6	0	-

G-M-G Total discharge volume unit*

generic-units-total-discharge

The following units of the total water discharge can be selected:

ID	Option	Description
1	l	Liter
2	m ³ (default)	Cubic meter
3	ft	Cubic feet

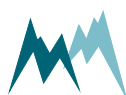

ID	Option	Description
4	ac-ft	Acre-feet
5	us. gal	US gallons
6	en. gal	English gallons
7	MI	Megaliter

G-M-H Total discharge volume decimal

generic-decimals-total-discharge

This parameter sets the number of decimal places for the total water discharge.

Value range	Default	Units
0...6	0	-

G-M-I Simulation, discharge volume

rq-discharge-simulation-SQ

With this function a user defined discharge volume can be simulated. This simulation is based on the settings in menus [Measurement trigger](#) and [Units and decimals](#).



EXAMPLE

The following SQ-R settings are assumed:

Discharge (Q), unit l/s

Discharge (Q) decimals 1

Total discharge volume unit* m³

Total discharge volume decimal 1

After pressing the button in SQ-Commander a window will pop up:

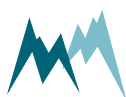

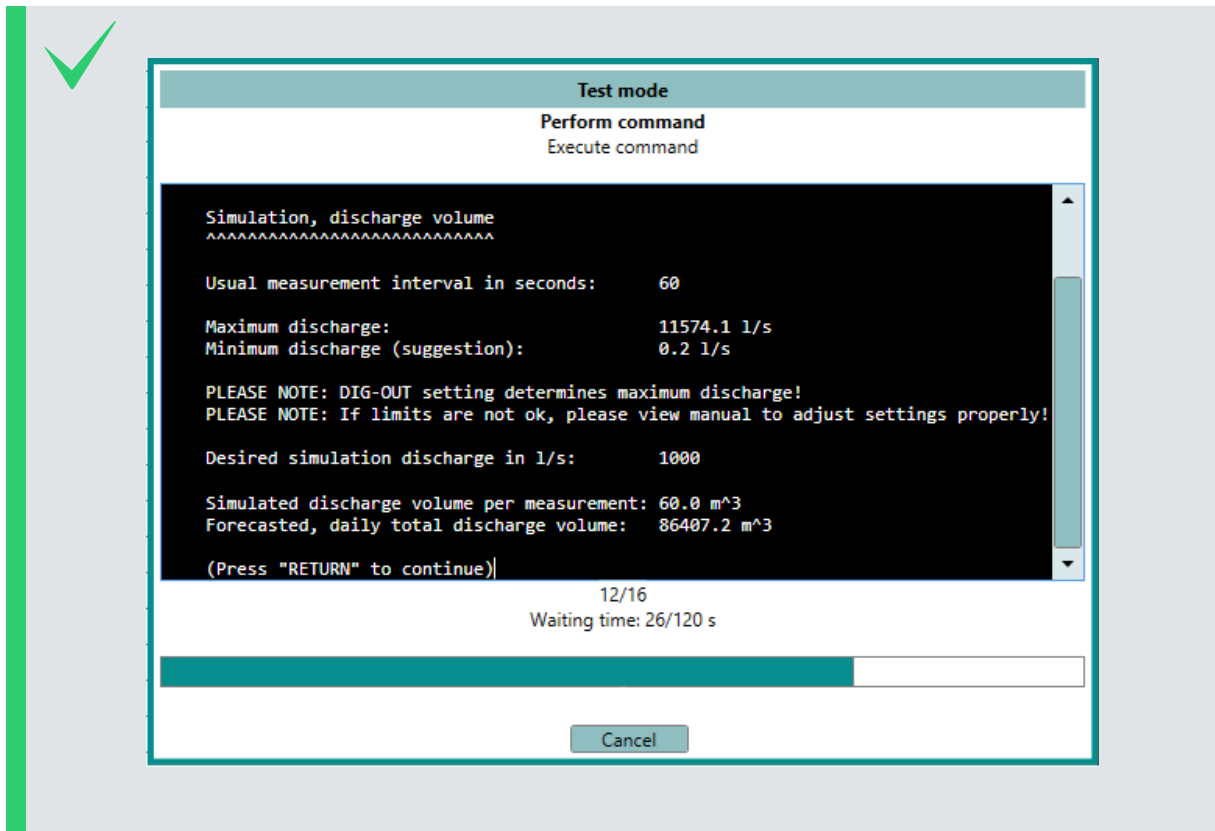

G-M-J Area (A), unit

generic-units-area

The following units of the cross-sectional area can be selected:

ID	Option	Description
1	dm ²	Square decimeter
2	m ² (default)	Square meter
3	ft ²	Square feet
4	yd ²	Square yard

G-M-K Area (A) decimals

generic-decimals-area

This parameter sets the number of decimal places for the cross-sectional area.

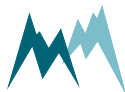

Value range	Default	Units
0...6	2	-

H Special functions

H-A	View spectral distribution	146
H-B	Veloc. radar inspection	146
H-C	Continuous meas. mode (temp).	146
H-D	View spectral trap	147
H-E	Set total discharge volume	147
H-F	View setup	147
H-G	Device status	147
H-H	W-v table view	148
H-I	W-v table reset	148
H-J	Set factory default	148
H-K	Temp. load factory default	148
H-L	Relaunch program	148
H-M	Replace program	148

H-A View spectral distribution

`generic-special-functions-view-spectral-distribution`

With this command the sensor is set into spectral mode. After 30 minutes the spectral mode is switched off automatically.

With the SQ-Commander software the spectra can be recorded, visualized and stored for expert analysis of the sensor signal, e.g. additional reflections.

H-B Veloc. radar inspection

`rq-discharge-veloc-radar-inspection`

Diagnostic tool for in-depth device analysis. Inactive, for in-house use only.

H-C Continuous meas. mode (temp).

`generic-special-functions-continuous-meas-mode`

Inactive in the SQ-Commander menu. This feature can be triggered in the SQ-Commander under the **Measurement (F3)** tab with the command **Start polling measurements** and then **Start polling WITH measurements**. When active, measurements are performed continuously, ignoring the specified measurement interval.

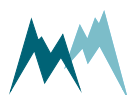

H-D View spectral trap

`rq-discharge-view-spectral-trap`

For expert use only! Inactive in the SQ-Commander menu.

The integrated velocity radar sensor has the option to save the spectra of special events. This command returns these spectra. One output contains four spectra.

Index	Option	Description
1	Stop	Spectrum of the last invalid measurement caused by a Stop event.
2	Reference	Spectrum of the measurement performed before the last event.
3	Trap	Spectrum of the measurement of the last event with the velocity increase according to menu item Spectral trap, veloc. rise .
4	Normal	Actual spectrum

H-E Set total discharge volume

`rq-discharge-set-total-volume`

With this function the total discharge volume can be set to a defined value, e.g. a reset to zero.



NOTE The total discharge has a maximum of 8 digits, including a comma (e.g. [99999999](#), [99999.99](#)). After the maximum has been reached, the total discharge is reset to [0](#).

H-F View setup

`generic-special-functions-view-setup`

All parameters of the SQ-R are listed in the terminal window.

H-G Device status

`generic-special-functions-device-status`

Displays information about the device and the software version.

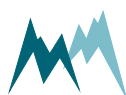

H-H W-v table view

`rq-discharge-w-v-table-view`

The learned W-v table is listed in the terminal window. Only available in terminal mode.

H-I W-v table reset

`rq-discharge-w-v-table-reset`

The learned W-v table is completely deleted and re-initiated.

H-J Set factory default

`generic-special-functions-set-factory-default`

All parameters are reset to factory defaults. Only available in terminal-mode.

H-K Temp. load factory default

`generic-special-functions-temp-load-factory-default`

Loads factory default values temporarily. Only available in terminal mode.

H-L Relaunch program

`generic-special-functions-relaunch-program`

The device is restarted. Powering the sensor off and on again is equivalent.

H-M Replace program

`generic-special-functions-replace-program`

The sensor is set into a "Boot Loader" mode for three minutes to upload new software remotely. Not required for local firmware update.

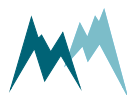

Appendix A Troubleshooting

A.1	Devices	149
A.1.1	The SQ-R is not responding or returns unreadable characters	149
A.1.2	The SQ-R reboots repeatedly	151
A.2	Measurement data	151
A.2.1	Measurement data are not updated	151
A.2.2	The SQ-R returns no or zero velocity	152
A.2.3	The SQ-R returns negative velocities	152
1.2.4	The SQ-R returns the wrong water level	153
A.2.5	The SQ-R continuously returns the same water level	153
1.2.6	The SQ-R returns no water discharge	154
A.2.7	The measured discharge is too low or too high	154
A.2.8	The SQ-R returns negative discharge values	155
A.2.9	Learned velocity and discharge are inconsistent	156
1.2.10	Quality values are low or negative	156
1.2.11	Velocity/level data show spikes	156
A.2.12	W-v table reset fails	157
A.3	Firmware & software	157
1.3.1	Registration of SQ-Commander fails	157
A.3.2	Commander loads wrong setup	157
A.3.3	Firmware update via RS-485 is aborted	158
A.4	RS-485	158
A.4.1	Configuration via terminal shows unexpected behavior	158
A.5	SDI-12	158
A.5.1	The SQ-R is not detected by a SDI-12 master device	158
A.6	Analog output	159
A.6.1	The 4-20 mA output is wrong	159

A.1 Devices

A.1.1 The SQ-R is not responding or returns unreadable characters

Reason	Solution
The power supply is not connected or turned off.	Check if the power supply is connected and on.
The polarity of connected power supply wires is wrong.	Check the polarity of connected wires.
Wrong sensor cable.	Use the original sensor cable configured by Sommer Messtechnik (only applicable to Sommer Messtechnik cables).

Reason	Solution
Power supply is insufficient. The SQ-R requires a certain inrush-current that the power supply is not able to provide.	<ol style="list-style-type: none"> 1. Use a power supply providing >0.5 A at 12 VDC or a fully charged battery. 2. In case of long sensor cables (>50 m) use a 24-VDC power supply. <p>Please note that power supplied by the USB-port is insufficient to power the SQ-R!</p>
The power supply voltage is out of range.	Adjust the power supply to match the specified voltage range.
The polarity of the connected RS-485-A and RS-485-B wires is wrong.	Reverse the polarity of the connected RS-485-A and RS-485-B wires.
The port settings of the SQ-R and the data acquisition system do not match.	<p>Use the SQ-Commander Communication assistant or adapt port settings on your device.</p> <div style="border-left: 2px solid #0070C0; padding-left: 10px; margin-top: 10px;"> <p> NOTE Sommer Messtechnik devices require the following Baud rates:</p> <ul style="list-style-type: none"> ● Sensor: 9600 ● Data logger: 115200 ● Modbus: 19200 <p>In case of doubt use the function Check port in the Communication assistant.</p> </div>
The SQ-R is set to Modbus.	Connect to the sensor using the Communication assistant of the SQ-Commander and select the Modbus option in the Serial connection .
A sensor wire is not connected firmly to the terminal of the data acquisition device.	Check the firm connection of the sensor wires.
A pin of the connector plug is bent or broken.	Verify that all connector pins are straight.
The sensor cable is damaged.	Replace the sensor cable.
The COM-port has not been assigned correctly to the USB converter.	<ol style="list-style-type: none"> 1. Make sure to use a Sommer Messtechnik USB converter. Third party converters are not supported. 2. Check the COM-port number using Windows Device Manager. 3. Plug in the USB converter first, then start SQ-Commander.

Reason	Solution
The USB converter is faulty.	Replace the USB converter.
The USB port on your PC is not working.	Use another USB port.
The driver of the USB converter was incorrectly installed	Reinstall the driver of the USB converter.

A.1.2 The SQ-R reboots repeatedly

Reason	Solution
The power supply has not enough current to start the SQ-R.	Verify that the power supply provides enough current. A SQ-R consumes up to 140 mA @ 12 V. If required, power the SQ-R by an additional or alternative supply.

A.2 Measurement data

A.2.1 Measurement data are not updated

The device is connected to the SQ-Commander, but the data are not updated.

Cause	Solution
Data traffic conflict	Reboot the device by interrupting the power supply.
The SQ-R was powered while the target of the level sensor was within its blanking distance.	Verify that the target is outside the blanking distance of the level sensor and reboot the device by interrupting the power supply.

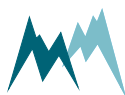

A.2.2 The SQ-R returns no or zero velocity

Reason	Solution
Water level has not been adjusted.	Perform a water level adjustment.
WLL, low level border is too high.	Verify correct setting of WLL, low level border.
SQ-R position and/or sensor settings do not match water flow conditions.	<ol style="list-style-type: none"> 1. Check settings in menu Velocity. 2. Check value of Quality (SNR) returned by the SQ-R. 3. Check value of Opposite direction returned by the SQ-R. Increase Stop, max. opp. direction. 4. Increase or decrease the vertical mounting position of the SQ-R. 5. Reverse the viewing direction of the SQ-R and adapt the setting Viewing direction.
Waves on water surface are insufficient	<ol style="list-style-type: none"> 1. Create surface waves using a chain, rope or other means upstream of the measurement spot. 2. If waves on the water surface look sufficient, toggle Channel type to open or vice versa. 3. Increase Measurement duration up to 60 s.

A.2.3 The SQ-R returns negative velocities

Reason	Solution
Stop, behavior is set to <i>use replace value</i>	Set Stop, behavior to <i>use learn value</i> or <i>hold</i> , or change Stop, replace value .
Stop, behavior is set to <i>use learn value</i> , but w-v table contains negative velocities. This may occur after a test period when different settings were applied or the sensor position was changed. This behavior may also appear if the learning period has been too short, i.e. the w-v table contains only one entry. In this case the SQ-R cannot determine a learned velocity and uses the replace value instead.	Reset the w-v table with the function W-v table reset in the menu Special functions . Set Stop, behavior to <i>hold</i> or <i>use replace value</i> with an appropriate value; change to <i>use learn value</i> as soon as the SQ-R the w-v table has gained multiple entries (use W-v table view to check).

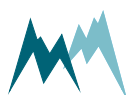

1.2.4 The SQ-R returns the wrong water level

Reason	Solution
Water level is not adjusted properly.	<p>Perform a water level adjustment.</p>  <p>NOTE The water level is the vertical distance between the deepest point of canal/river and the water surface.</p>
The SQ-R is installed improperly and/or water level settings are inappropriate.	<ol style="list-style-type: none"> 1. Verify that the SQ-R is mounted within its measurement range (see Specifications). 2. Verify that the SQ-R is installed parallel to the water surface. 3. Make sure that no obstacles extend into the measurement beam. 4. Deactivate the moving data filter (Filter, no. of values). 5. Perform a level test and verify the correct reading. 6. Switch Supply to <i>always on</i>. 7. Verify units and decimals of water level.

A.2.5 The SQ-R continuously returns the same water level

Reason	Solution
Supply in setup menu Tech. level (W) is set to <i>always on</i> .	Change setting to <i>switched</i> . If set to <i>always on</i> , the level sensor of the SQ-R does not receive the measurement trigger.
The water level is outside the measurement range of the SQ-R.	Check the water level with the function Test in setup menu Level (W) . Check the values of WCF , cease to flow level and WMA, maximum level . If these levels are different from <i>0</i> , the measured water level must be within the range of these two settings. Otherwise, the SQ-R returns the hold value.
The unit of the water level is <i>m</i> or <i>ft</i> and the decimals are <i>0</i> . Thus, small changes in water levels are not resolved.	Change the unit to <i>mm</i> or <i>in</i> , or add decimals.

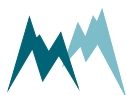

1.2.6 The SQ-R returns no water discharge

Reason	Solution
The SQ-R does not have the correct cross-sectional profile available.	<ol style="list-style-type: none"> 1. Verify that the measured water level is within the range covered by the cross sectional profile. 2. Upload the cross-sectional profile again.
Water level has not been adjusted.	Perform a water level adjustment.
WLL, low level border is set too high.	Verify that WLL, low level border is correct.
The SQ-R does not detect the flow velocity.	<ol style="list-style-type: none"> 1. Verify that the flow velocity reading is correct. 2. Check Velocity settings. 3. Check Quality (SNR) returned by the SQ-R. 4. Check Opposite direction and increase Stop, max. opp. direction.
Units and decimals of water discharge are inappropriate	Verify that units and decimals of water discharge are suitable.

A.2.7 The measured discharge is too low or too high

Reason	Solution
The SQ-R reports a self-check code >5.	Work off the self-check codes as described in Device status .
The orientation of the SQ-R is not parallel to the flow direction.	Turn the SQ-R parallel to the flow direction.
The SQ-R is not parallel to the water surface.	Tilt the SQ-R until it is parallel to the water surface. If you cannot tilt the sensor, enter the angle between the sensor and the water surface into River inclination .
Opposite direction content is too high.	<ul style="list-style-type: none"> - Reverse the orientation of the SQ-R and set Viewing direction accordingly. - Move the SQ-R to a different position.

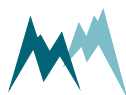

Reason	Solution
Cross-sectional profile is wrong or out of date.	Correct the cross-sectional profile. <ul style="list-style-type: none"> - Does the profile represent the current cross-section? - Is the profile high enough to contain the highest expected water levels? - Is the zero water level at the deepest point of the profile? - Is the sensor position correct? - Is the roughness correct?
The SQ-R has an outdated discharge table.	Upload the discharge table to the SQ-R again.
The water level is incorrect.	Perform a water level adjustment. Make sure the water level is measured correctly: from the deepest point to the water surface.
Velocity measurement duration is too short.	Increase Measurement duration by 10 to 20 s.
Minimum velocity is set too high.	Decrease Minimum velocity to min. 0.8 m/s.
Channel type selected in SQ-Commander is inappropriate.	Change Channel type from open to closed or vice versa.
Clogging or an obstruction is creating back-water.	Verify that the water below the SQ-R is free flowing.
The water flow conditions are outside the limits of the radar sensor, e.g., <ul style="list-style-type: none"> - Extremely slow moving water - Glassy surface with no ripples - Extremely turbulent water (white water) - Water flow with intense vortices 	Change the measurement site.

A.2.8 The SQ-R returns negative discharge values

Reason	Solution
The SQ-R records negative velocities.	See The SQ-R returns negative velocities.

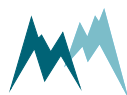

A.2.9 Learned velocity and discharge are inconsistent

Reason	Solution
The learned discharge table (W-v table) contains data from previous measurement campaigns.	Click W-v table view in the menu Special functions to display the content of the W-v table. Check the consistency of the listed data. If required, click W-v table reset to build the learned discharge table anew.

1.2.10 Quality values are low or negative

Reason	Solution
Opposite direction content is high (> 150%)	Reverse viewing direction
Wind generates a secondary wave pattern	<ul style="list-style-type: none"> • Select a different monitoring location • If wind is not a permanent issue: Set Stop, max. opp. direction in menu Technics > Tech.velocity to about 150% and allow the SQ-R to fill the learned discharge table. This may take several weeks to month, depending on the water level variation of the river/canal. After the learning time, increase Stop, max. opp. direction to about 250% or more.

1.2.11 Velocity/level data show spikes

Reason	Solution
Water surface is rough.	<ol style="list-style-type: none"> 1. Verify if spikes are plausible. If a single spike extends over multiple measurements, the observed shift may be real. 2. Apply a moving data filter (see Velocity and Level (W)). 3. Switch Supply to <i>always on</i>. 4. Increase Measurement duration up to 60 s.

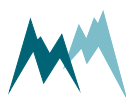

A.2.12 W-v table reset fails

After clicking [W-v table reset](#), the reset process is aborted and the W-v table is not updated.

Cause	Solution
The SQ-R is connected to an MRL data logger and the Flow control of the SQ-R and the MRL do not match.	Make sure the Flow control of sensor and logger match. Generally, this is <i>XOFF-XON blocking</i> .

A.3 Firmware & software

1.3.1 Registration of SQ-Commander fails

Reason	Solution
The SQ-Commander was not regularly installed with the supplied installation file, or the installation directory has been copied from another PC.	Uninstall/remove SQ-Commander and reinstall it from the supplied installation file (commander.msi).

A.3.2 Commander loads wrong setup

If the setup is reloaded from the device the SQ-Commander seems to display an old version.

Cause	Solution
The device has been connected to the same PC before and several different setup files have been loaded.	<ul style="list-style-type: none"> • In the Communication section of the SQ-Commander, select Mode Connection and click on the trash can icon on the right edge. Then, reload the setup from the device. • Delete the setup files of the device that have been downloaded by SQ-Commander to the folder C:\Users\Public\Documents\Sommer\Setup. The respective files can be identified by the serial number in the file name and the file date.

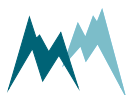

A.3.3 Firmware update via RS-485 is aborted

Reason	Solution
USB to RS-485 converter cable is damaged or can only operate on 9600 baud.	Replace USB to RS-485 converter cable. The programmer requires 57600 baud.

A.4 RS-485

A.4.1 Configuration via terminal shows unexpected behavior

Accessing the parameter menus in the terminal leads to unexpected behavior, e.g. after entering a menu character the terminal displays repeated error messages or jumps out of the parameter menu.

Reason	Solution
The sensor, power supply and PC/laptop do not share the same ground.	Verify that all equipment is connected to the same ground.

A.5 SDI-12

A.5.1 The SQ-R is not detected by a SDI-12 master device

Reason	Solution
The SQ-R and the SDI-12 master have different grounds.	Verify that the SQ-R and the SDI-12 master are connected by a ground (GND) wire.

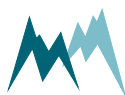

A.6 Analog output

A.6.1 The 4-20 mA output is wrong

Reason	Solution
Analog output settings incorrect.	<ol style="list-style-type: none"> 1. Check analog output settings. 2. Run Simulate current output and verify the correct output.
Sensor and data acquisition system have different grounds.	Verify that sensor and data acquisition system have the same ground.
The analog output is read by a data acquisition system and the scaling is wrong.	Verify scale and offset on your data acquisition system.
Two or more analog outputs of the SQ-R are read by a data acquisition system and the wiring is wrong, e.g. IOUT1 is read as IOUT2.	Verify the wiring on your data acquisition system and swap the wires if required.
The 4-20 mA output is delayed by approx. 150 ms. If the output is read before, a wrong value is acquired.	Sample the 4-20 mA output with a delay of more than 150 ms.

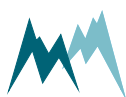

Appendix B Unwanted reflections

B.1 Open channel

Depending on the dimensions of the water channel in which the SQ-R sensor is installed in, unwanted reflections may occur and distort the velocity spectrum. Such reflections can be detected by looking at a recorded velocity spectrum as shown in the following example:

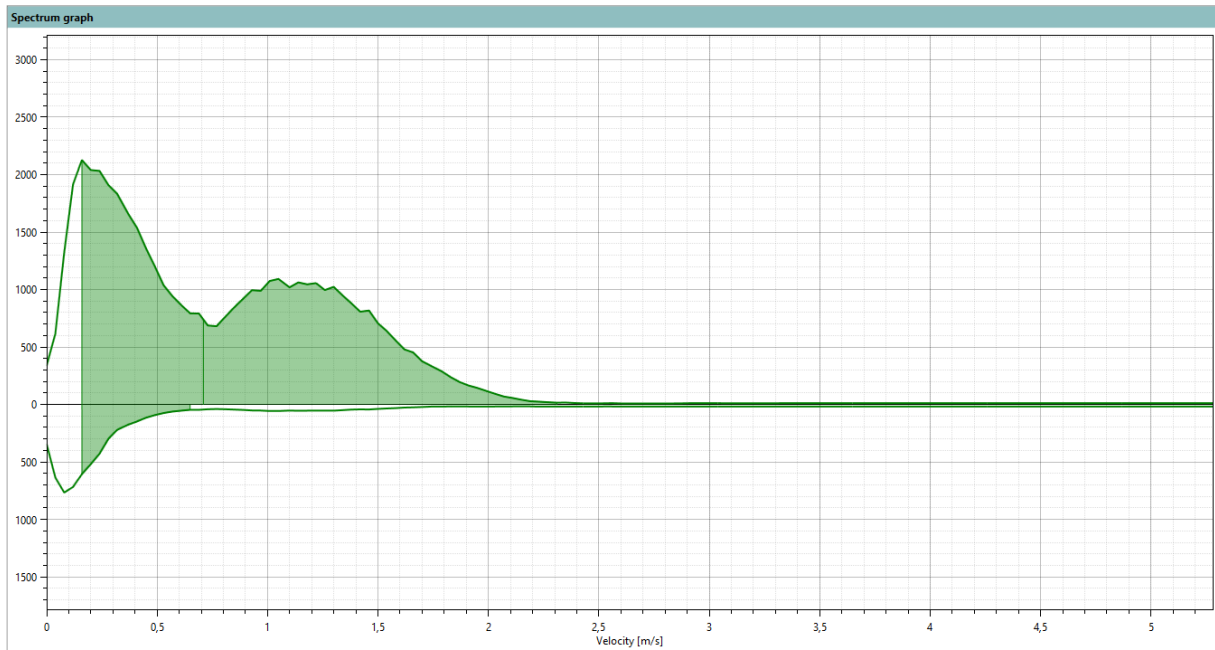
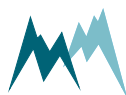

Figure 1 Velocity spectrum containing unwanted reflections



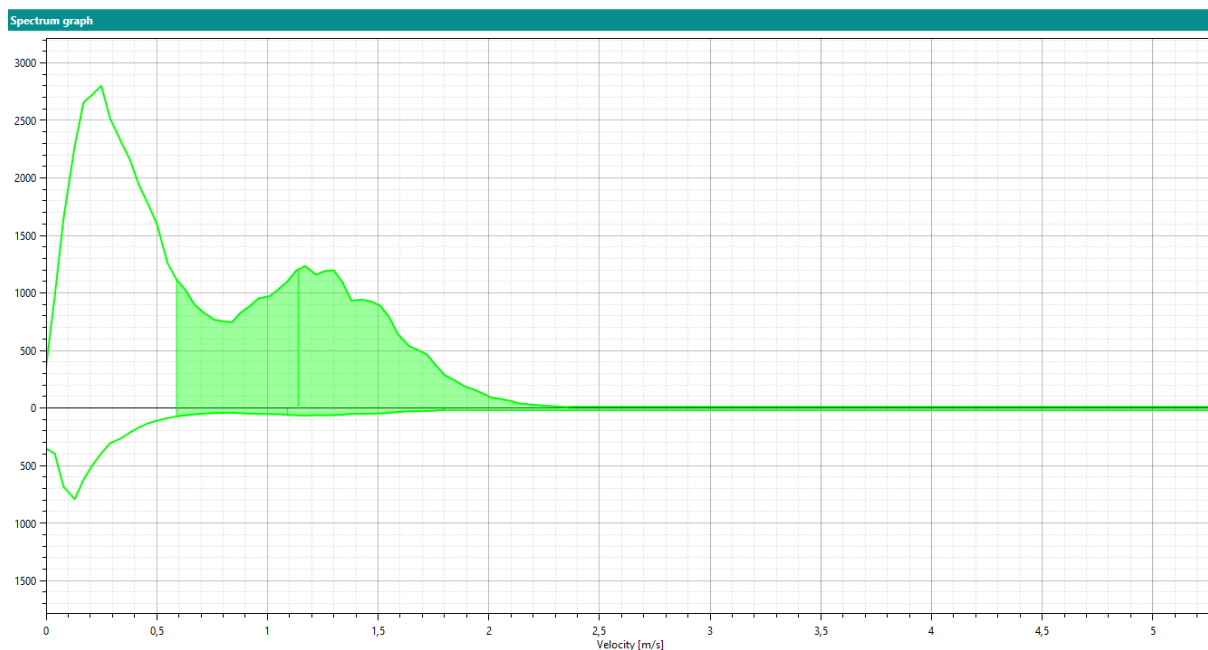

Figure 2 Velocity spectrum with adjusted minimum velocity

In the spectrum of [Figure 1](#) two peaks can be observed: The first at approximately 0.15 m/s and the second at approx. 1.2 m/s. The shaded area is considered by the implemented algorithm to calculate the flow velocity. In this example the sensor determined a velocity of 0.71 m/s.

A second, independent measurement at the site revealed a flow velocity of 1.1 ... 1.2 m/s. The discrepancy between these two results can be attributed to reflections on the channel wall, which caused a secondary peak in the spectrum at 0.15 m/s.

This means the first peak in the spectrum (at 0.15 m/s) is caused by an unwanted reflection in the channel where the SQ-R is installed. The result is that the algorithm implemented in the SQ-R is not able to determine the correct velocity. Due to the low velocity of the first peak the determined (and output-ted) velocity is lower than the real velocity:

To suppress this undesired behavior the setting [Minimum velocity](#) has to be set to a velocity higher than that of the first peak. [Appendix B](#) shows the result of this procedure: The first peak is not shaded anymore, meaning it is not considered for the velocity calculation. Only the second peak is used by the algorithm and the calculated flow velocity of 1.15 m/s is in agreement with the velocity of the comparison measurement.

B.2 Closed channel

The example described above is valid for open channels only. If the SQ-R sensor is applied in a closed channel and the configuration [Channel type](#) is set to closed the first peak in the velocity spectrum is

ignored. This peak results from reflections at the channel wall is removed before the velocity calculation.

2.3 Examples of velocity spectra

The images below show different spectra as they are encountered in rivers and canals.



NOTE

The colors are random and do not indicate the quality of the spectra.

Upward looking peaks refer to upstream measurements, downward looking peak to downstream measurements.

	<ul style="list-style-type: none"> ● One distinct peak ● High intensity ● Smooth ● Negligible opposite direction
	<ul style="list-style-type: none"> ● One distinct peak ● High intensity ● Smooth ● Negligible opposite direction
	<ul style="list-style-type: none"> ● One distinct peak ● High intensity ● Little noise ● Negligible opposite direction
	<ul style="list-style-type: none"> ● One distinct peak ● High intensity ● Little noise ● Negligible opposite direction

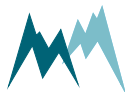

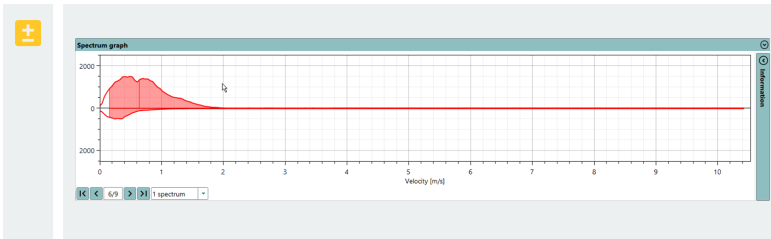

- Two little peaks
- Small opposite direction

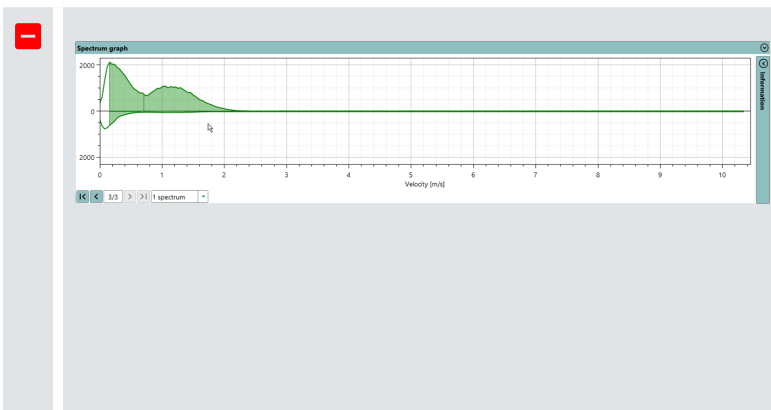

- Two peaks

What you can do:

- Change the sensor location
- Reduce or increase the vertical mounting position
- Align sensor parallel to flow direction
- Increase the measurement duration

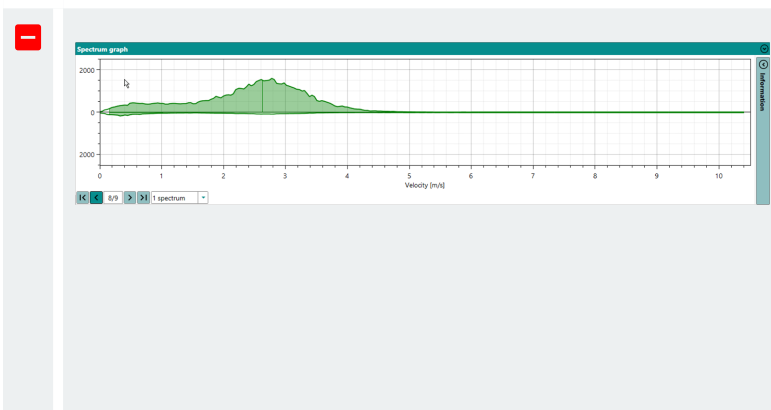

- Peak with a tail

What you can do:

- Reduce or increase the vertical mounting position
- Change the sensor location
- Increase the measurement duration
- Align sensor parallel to flow direction

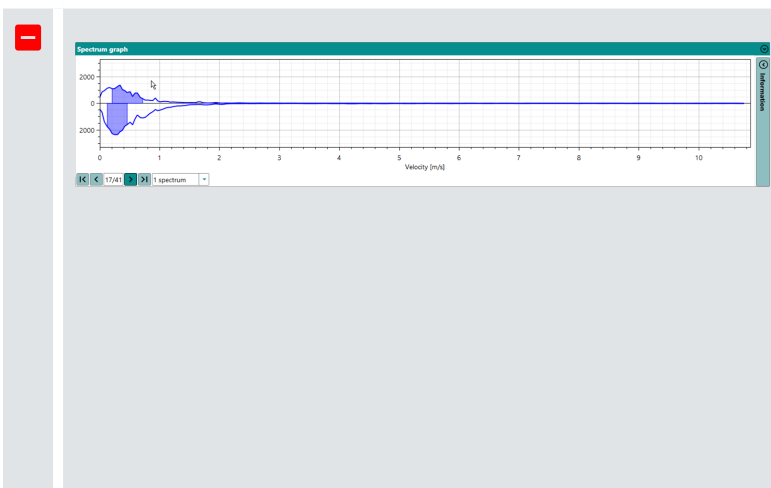

- High opposite direction content
- Noisy

What you can do:

- Align sensor parallel to flow direction
- Reduce or increase the vertical mounting position
- Increase the measurement duration
- Change the sensor location

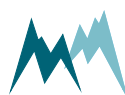

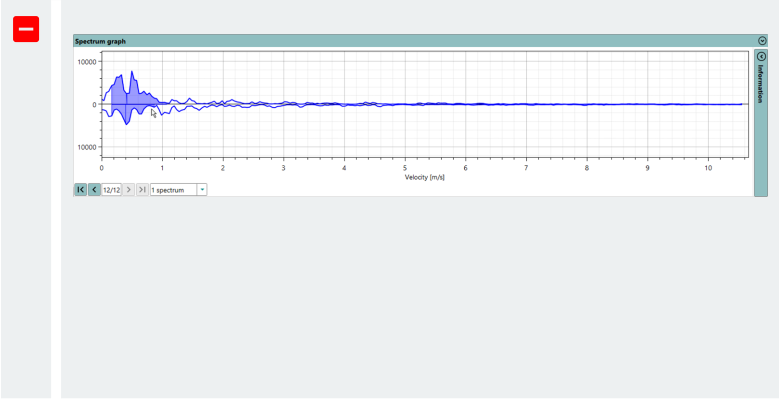

- Extreme noise

What you can do:

- Place a chain, rope or other item upstream into the water to create additional waves
- Increase the measurement duration
- Switch **Channel type** to closed or vice versa

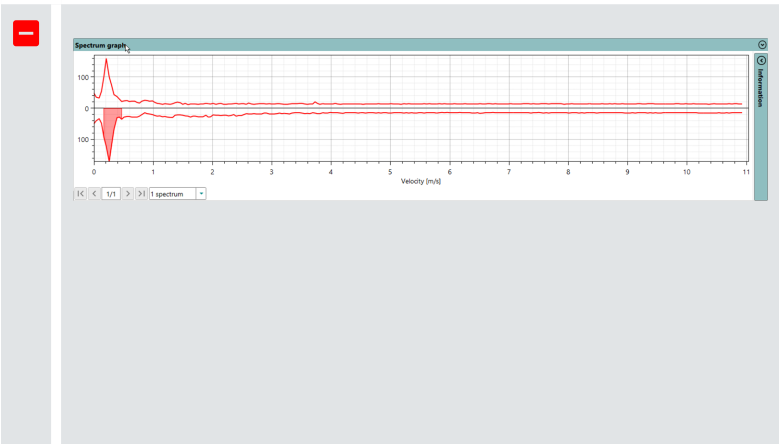

- Very low velocity
- Very low intensity

What you can do:

- Place a chain, rope or other item upstream into the water to create additional waves
- Increase the measurement duration
- Switch **Channel type** to closed or vice versa

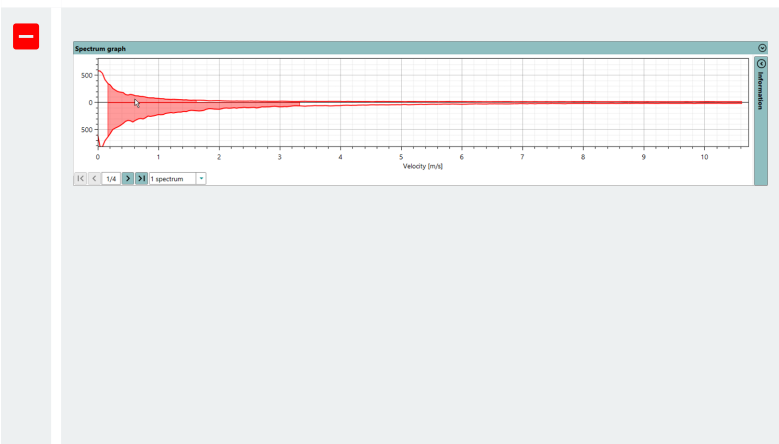

- No peak
- Very low intensity

What you can do:

- Place a chain, rope or other item upstream into the water to create additional waves
- Increase the measurement duration
- Switch **Channel type** to closed or vice versa

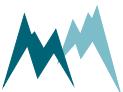

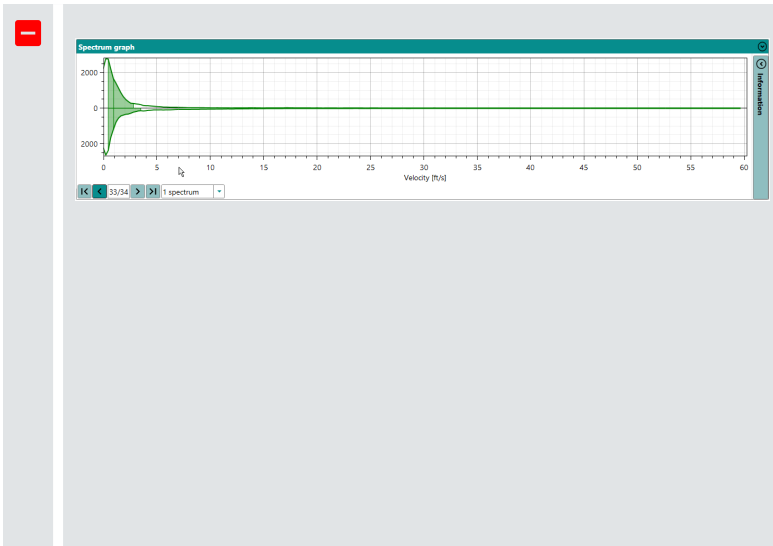

- Symmetric spectrum around zero at low velocities
- High intensity

Reason

- Glassy water surface with lake-like waves
- SQ-R measures vertical velocity

What you can do:

- Place a chain, rope or other item upstream into the water to create additional waves
- Change the sensor location

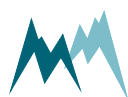

Appendix C CRC-16 array

CRC-16 array

```
1  crc16tab[] =
2  {
3  0x0000, 0x1021, 0x2042, 0x3063, 0x4084, 0x50A5, 0x60C6, 0x70E7,
4  0x8108, 0x9129, 0xA14A, 0xB16B, 0xC18C, 0xD1AD, 0xE1CE, 0xF1EF,
5  0x1231, 0x0210, 0x3273, 0x2252, 0x52B5, 0x4294, 0x72F7, 0x62D6,
6  0x9339, 0x8318, 0xB37B, 0xA35A, 0xD3BD, 0xC39C, 0xF3FF, 0xE3DE,
7  0x2462, 0x3443, 0x0420, 0x1401, 0x64E6, 0x74C7, 0x44A4, 0x5485,
8  0xA56A, 0xB54B, 0x8528, 0x9509, 0xE5EE, 0xF5CF, 0xC5AC, 0xD58D,
9  0x3653, 0x2672, 0x1611, 0x0630, 0x76D7, 0x66F6, 0x5695, 0x46B4,
10 0xB75B, 0xA77A, 0x9719, 0x8738, 0xF7DF, 0xE7FE, 0xD79D, 0xC7BC,
11 0x48C4, 0x58E5, 0x6886, 0x78A7, 0x0840, 0x1861, 0x2802, 0x3823,
12 0xC9CC, 0xD9ED, 0xE98E, 0xF9AF, 0x8948, 0x9969, 0xA90A, 0xB92B,
13 0x5AF5, 0x4AD4, 0x7AB7, 0x6A96, 0x1A71, 0x0A50, 0x3A33, 0x2A12,
14 0xDBFD, 0xCBDC, 0xFBBF, 0xEB9E, 0x9B79, 0x8B58, 0xBB3B, 0xAB1A,
15 0x6CA6, 0x7C87, 0x4CE4, 0x5CC5, 0x2C22, 0x3C03, 0x0C60, 0x1C41,
16 0xEDAE, 0xFD8F, 0xCDEC, 0xDDCD, 0xAD2A, 0xBD0B, 0x8D68, 0x9D49,
17 0x7E97, 0x6EB6, 0x5ED5, 0x4EF4, 0x3E13, 0x2E32, 0x1E51, 0x0E70,
18 0xFF9F, 0xEFBE, 0xDFDD, 0xCFFC, 0xBF1B, 0xAF3A, 0x9F59, 0x8F78,
19 0x9188, 0x81A9, 0xB1CA, 0xA1EB, 0xD10C, 0xC12D, 0xF14E, 0xE16F,
20 0x1080, 0x00A1, 0x30C2, 0x20E3, 0x5004, 0x4025, 0x7046, 0x6067,
21 0x83B9, 0x9398, 0xA3FB, 0xB3DA, 0xC33D, 0xD31C, 0xE37F, 0xF35E,
22 0x02B1, 0x1290, 0x22F3, 0x32D2, 0x4235, 0x5214, 0x6277, 0x7256,
23 0xB5EA, 0xA5CB, 0x95A8, 0x8589, 0xF56E, 0xE54F, 0xD52C, 0xC50D,
24 0x34E2, 0x24C3, 0x14A0, 0x0481, 0x7466, 0x6447, 0x5424, 0x4405,
25 0xA7DB, 0xB7FA, 0x8799, 0x97B8, 0xE75F, 0xF77E, 0xC71D, 0xD73C,
26 0x26D3, 0x36F2, 0x0691, 0x16B0, 0x6657, 0x7676, 0x4615, 0x5634,
27 0xD94C, 0xC96D, 0xF90E, 0xE92F, 0x99C8, 0x89E9, 0xB98A, 0xA9AB,
28 0x5844, 0x4865, 0x7806, 0x6827, 0x18C0, 0x08E1, 0x3882, 0x28A3,
29 0xCB7D, 0xDB5C, 0xEB3F, 0xFB1E, 0x8BF9, 0x9BD8, 0xABBB, 0xBB9A,
30 0x4A75, 0x5A54, 0x6A37, 0x7A16, 0x0AF1, 0x1AD0, 0x2AB3, 0x3A92,
31 0xFD2E, 0xED0F, 0xDD6C, 0xCD4D, 0xBDAA, 0xAD8B, 0x9DE8, 0x8DC9,
32 0x7C26, 0x6C07, 0x5C64, 0x4C45, 0x3CA2, 0x2C83, 0x1CE0, 0x0CC1,
33 0xEF1F, 0xFF3E, 0xCF5D, 0xDF7C, 0xAF9B, 0xBFBA, 0x8FD9, 0x9FF8,
34 0x6E17, 0x7E36, 0x4E55, 0x5E74, 0x2E93, 0x3EB2, 0x0ED1, 0x1EF0
35 }
```

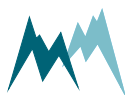

Glossary

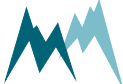

Index

M

Modbus 25, 60, 91-95, 136, 150

R

RS-485 15, 23, 25, 38, 40, 43, 60, 72-75, 82,
86, 92, 95, 104, 124, 133-134, 136,
150, 158

S

SDI-12 24-25, 38, 41, 60, 74, 86-90, 104,
121, 125, 158

