

MRL-IE, MRL-IEa

Analog extension module

Manual

Setup version 3.23.02 (Firmware 3.07.00)

09.06.2022



Sommer Messtechnik

All rights reserved.

The Copyrights for this manual are exclusively owned by

Sommer Messtechnik
6842 Koblach
Austria

This manual or parts of it may only be copied or passed on to third parties with written permission of Sommer Messtechnik. This applies to printed as well as digital issues of this manual.



Sommer Messtechnik
Strassenhäuser 27
6842 Koblach
Austria
www.sommer.at
E office@sommer.at
T +43 5523 55989
F +43 5523 55989-19

Validity

This manual applies to the Analog extension module with the setup version 3.23.02, including all its subversions.

Created: 01.01.2020

Last update: 09.06.2022



EU conformity



This product is in conformity with the following standards:

EMC	2014/30/EU	EN 301 489-1 V1.9.2
LVD	2014/35/EU	EN 62311:2008
		EN 62368-1:2014
RoHS II	2011/65/EU	
RoHS III	2015/863/EU	

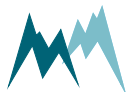

Safety information

Please read this manual carefully before installing or operating this equipment. Non-compliance with the instructions given in this manual can result in failure or damage of the equipment or may put people at risk by injuries through electrical or mechanic impact.

- Make sure that the personnel responsible for installation, configuration and maintenance is familiar with the applicable regulations and standards!
- Do not perform any installations in bad weather conditions, e.g. thunderstorms.
- Prior to installation of equipment inform the owner of the measurement site or the authority responsible for it. Upon completion, secure the installation from trespassers.
- Maintenance and repair must be performed by trained personnel or an engineer of Sommer Messtechnik. Only replacement parts supplied by Sommer Messtechnik should be used for repairs.
- Make sure that NO power is connected to the equipment during installation and wiring!
- Only use a power supply that complies with the power rating specified for this equipment!
- Keep equipment dry during wiring and maintenance!
- If applicable, it is recommended to use accessories of Sommer Messtechnik with this equipment.

Disposal



After this device has reached the end of its lifetime, it must not be disposed of with household waste! Instead, dispose of the device by returning it to a designated collection point for the recycling of waste electrical and electronic equipment.

Dispose of batteries separately!



Feedback

Should you come across any error in this manual, or if you miss information to handle and operate the MRL-IE we are pleased to receive your feedback to office@sommer.at.



Content

- 1 What is the MRL-IE? 11
- 2 Unpacking 12
- 3 How do I start? 13
 - 3.1 Connect the MRL-IE to a PC 13
 - 3.2 Configure the MRL-IE 13
 - 3.3 View live measurements 14
- 4 What can I do with it? 15
 - 4.1 Measurement options 15
 - 4.1.1 Analog measurements 16
 - 4.1.2 Counts & frequency 16
 - 4.1.3 SDI-12 data acquisition 16
 - 4.1.4 Serial RS-485 data acquisition 17
 - 4.2 Signal output (MRL-IEa) 17
 - 4.3 Sensor power supply 17
 - 4.4 Communication options 18
 - 4.4.1 Direct connection to a PC 18
 - 4.4.2 Radio connection 18
- 5 Versions 19
- 6 Specifications 20
- 7 Components 22
 - 7.1 Terminals 22
 - 7.2 Analog output terminals (MRL-IEa) 24
- 8 Installation 26
 - 8.1 Where should I install the MRL-IE? 26
 - 8.2 Required tools and equipment 26
 - 8.3 How do I install the MRL-IE? 26
 - 8.3.1 Mounting 26
 - 8.3.2 Power supply 27
 - 8.3.3 Signal cables 27
 - 8.3.4 Lightning protection 28
- 9 Operation 29

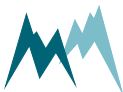

9.1	Status of LEDs	29
9.2	How to open the data logger housing	29
9.3	How to use the spring clips	30
9.4	How to connect a sensor	31
9.5	How to wire analog outputs	32
9.6	How to wire digital outputs	32
9.7	How to set the clock	33
9.8	How to replace the internal lithium battery	33
10	Maintenance	35
10.1	Calibration	35
11	Support software Commander	36
11.1	Software features	36
11.2	System requirements	36
11.3	Installation of Commander	36
11.4	Change authorization	41
11.5	Working with connections	42
11.5.1	Establish a connection with the Communication assistant	42
11.5.2	Establish a connection manually	42
11.5.3	Create a new connection	42
11.6	Working with stations	43
11.6.1	Create a station with the Communication assistant	43
11.6.2	Create a station manually	47
11.7	Working with measurements	48
11.7.1	Poll continuous measurements	48
11.7.2	Record measurements	49
11.8	Working with data	49
11.8.1	View live data	49
11.9	Working with setups	49
11.9.1	Download setup	49
11.9.2	Open a setup file	50
11.9.3	Edit setup	50
11.9.4	Upload new setup file	50
11.10	Update firmware	51
12	Configuration of the MRL-IE	53
12.1	Configuration with Commander support software	53
12.2	Configuration with a terminal program	55
12.3	Configuration errors	57
12.3.1	Conflict messages	57
12.3.2	Parameter conflicts	58
12.3.3	Setup conflicts	59

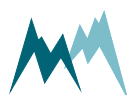

12.4	What do I need to configure?	59
12.4.1	General settings	60
12.4.2	Measurement table	60
12.4.3	Analog inputs	61
12.4.4	Analog output settings (MRL-IEa only)	61
12.4.5	Digital output settings (MRL-IEa only)	61
12.4.6	Totalizer reset options	62
12.4.7	Device clock	62
13	Communication	63
13.1	Communication protocols	63
13.2	Data output	63
13.2.1	Output values	63
13.2.2	Exception values	64
13.3	RS-485	64
13.3.1	What is RS-485?	64
13.3.2	What can I do with it?	64
13.3.3	Configuration	65
13.3.4	Data output options	66
13.3.5	Sommer bus protocol (SBP)	66
13.3.6	Standard protocol	69
13.3.7	Sommer old protocol	70
13.3.8	Serial commands	71
13.3.9	Sommer CRC-16	73
13.4	SDI-12	74
13.4.1	What is SDI-12?	74
13.4.2	What can I do with it?	75
13.4.3	Configuration	75
13.4.4	Data structure	75
13.4.5	SDI-12 commands	76
13.5	Modbus	80
13.5.1	What is Modbus?	80
13.5.2	What can I do with it?	81
13.5.3	Wiring	81
13.5.4	Modbus configuration	81
13.5.5	Modbus commands and registers	87
13.5.6	Reactivate Sommer protocol	90
13.5.7	PLC integration	94
14	Data acquisition examples	95
14.1	Power considerations	95
14.2	Analog measurements	95
14.2.1	Principals	96
14.2.2	Single ended voltage measurement	97

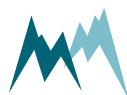

14.2.3	Differential voltage measurement	98
14.2.4	Current measurement	98
14.2.5	Resistance measurement	99
14.3	Counter & frequency measurements	99
14.3.1	Counting events	99
14.3.2	Frequency measurement	100
14.4	RS-485	101
14.4.1	Principles	101
14.4.2	Multiple RS-485 devices	102
14.4.3	Find RS-485 devices with Commander	102
14.4.4	Reading data from a Sommer RS-485 device	102
14.4.5	Reading data in MIO-format	103
14.4.6	Trigger measurements of a Sommer RS-485 device	104
14.5	SDI-12	105
14.5.1	Principles	106
14.5.2	Measurements with an SDI-12 sensor	106
15	Signal output examples	109
15.1	Current output	109
15.2	Pulse output	109
15.2.1	How to simulate pulse output	110
15.3	Limit monitoring	112
16	Parameter definitions	113
A	Measurement trigger	113
B	Measurement Interval	113
C	Interval statistics function	114
D	Measurements, max. number	114
E	Aux measurements, max. number	114
F	Measurement table	115
G	Technics	121
G-A	SBP device addressing	121
G-A-A	Device number	121
G-A-B	System key	121
G-A-C	Enable network scan	122
G-B	RS485-1 (COM)	122
G-B-A	Output protocol	122
G-B-A-A	Protocol type	122
G-B-A-B	Measurement output	123
G-B-A-C	Information	123
G-B-A-D	Wake-up sequence	123
G-B-A-E	Prefix holdback	124
G-B-A-F	MODBUS, set default	124

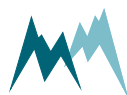

	G-B-A-G MODBUS, device address	124
G-B-B	Port	125
	G-B-B-A Baud rate	125
	G-B-B-B Parity, stop bits	125
	G-B-B-C Minimum response time	126
	G-B-B-D Transmitter warm-up time	126
	G-B-B-E Flow control	126
G-C	SDI-12 Slave	127
	G-C-A SDI-12 address	127
	G-C-B SDI12 'M'-response	127
G-D	Additional settings	128
	G-D-A Sommer ID	128
	G-D-B Sleep mode	128
	G-D-C Block size, data load	128
	G-D-D Internal low volt. disconnect	129
	G-D-E SommerXF starts with BOM	129
G-E	Inputs	130
	G-E-A RS485-2	130
	G-E-A-A Sensor supply (always on)	130
	G-E-A-B SBP sensor feedback	130
	G-E-A-C Port	132
	G-E-A-D Trigger	134
	G-E-B SDI-12 Master	135
	G-E-B-A Max. measurement duration	135
	G-E-B-B Sensor supply (always on)	136
	G-E-B-C Sensor search	136
	G-E-B-D Change sensor address	136
	G-E-B-E SDI-12 address	136
	G-E-B-F Transparency to SDI-12	136
	G-E-C Analog inputs	137
	G-E-C-A AIN signal type	137
	G-E-C-B Warm-up time	137
	G-E-C-C ADC - conv. Rate	138
	G-E-C-D ADC filter	138
	G-E-C-E Sensor supply	138
	G-E-D Additional meas. settings	140
	G-E-D-A 12V / 14V output voltage	140
	G-E-D-B Wind speed measurement duration	141
	G-E-D-C Sum, reset time	141
	G-E-D-D Conversion table A	141
	G-E-D-E Conversion table B	141
G-F	Analog outputs (MRL-IEa only)	141
	G-F-A Overview (MRL-IEa)	141

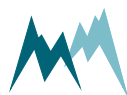

	G-F-B	Simulate current output	142
	G-G	Digital outputs (MRL-IEa only)	142
H		Region format	144
	H-A	Language/Sprache	144
	H-B	Decimal character	144
I		Special functions	145
	I-A	Device status	145
	I-B	Last date sync.	145
	I-C	Last time sync.	145
	I-D	View setup	145
	I-E	Continuous meas. mode (temp).	145
	I-F	Set factory default	146
	I-G	Temp. load factory default	146
	I-H	Relaunch program	146
	I-I	Replace program	146
Appendix A		Troubleshooting	147
	1.1	Configuration errors	147
		1.1.1 Conflict messages	147
		1.1.2 Parameter conflicts	148
		1.1.3 Setup conflicts	149
	A.2	Devices	150
		A.2.1 The MRL-IE is not responding or returns unreadable characters	150
		A.2.2 The MRL-IE reboots repeatedly	150
	A.3	Measurement data	151
		A.3.1 Measurement data are not updated	151
	A.4	Firmware & software	151
		A.4.1 Commander loads wrong setup	151
		A.4.2 Firmware update via RS-485 is aborted	151
	A.5	SDI-12	152
		A.5.1 The MRL-IE is not detected by a SDI-12 master device	152
		A.5.2 Data logger receives no SDI-12 data	152
	A.6	Modbus	153
		A.6.1 Modbus function 04 returns obscure measurement values	153
	A.7	Tips & tricks	153
		A.7.1 Send multiple SDI-12 requests	153
Appendix B		Sensor connections	155
Appendix C		CRC-16 array	156

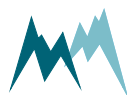

1 What is the MRL-IE?

The MRL-IE is a compact data acquisition module designed to acquire, process and transmit all sorts of environmental data. It is compatible with all sensors offered by SOMMER Messtechnik and numerous third-party devices equipped with analog or SDI-12 interfaces. The MRL-IE extends the input ports of Sommer Messtechnik MRL data loggers and offers conversion between RS-485 and SDI-12 signals.

The MRL-IEa is equipped with an additional analog output board that adds multiple analog, pulse and digital switch outputs.

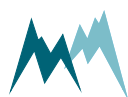

2 Unpacking

When unpacking your MRL-IE sensor box please make sure that the following items are present:

Qty.	Name
1	MRL-IE in the required configuration
1	Manual and Commander Software on USB stick
5	Blanking plug for unused cable glands

In case of missing or damaged items please contact your Sommer Messtechnik sales partner.

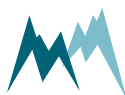

3 How do I start?

Follow the steps below to get the first measurement:



NOTE Perform the first start-up in your lab or office before installing the equipment in the field!

3.1 Connect the MRL-IE to a PC

1. Install the Commander support software (see [Installation of Commander](#))
2. Connect the RS-485to USB converter cable to the MRL-IE and a USB port on your PC.
3. Connect a 9...28 VDC power supply to the MRL-IE as shown in the figure below.

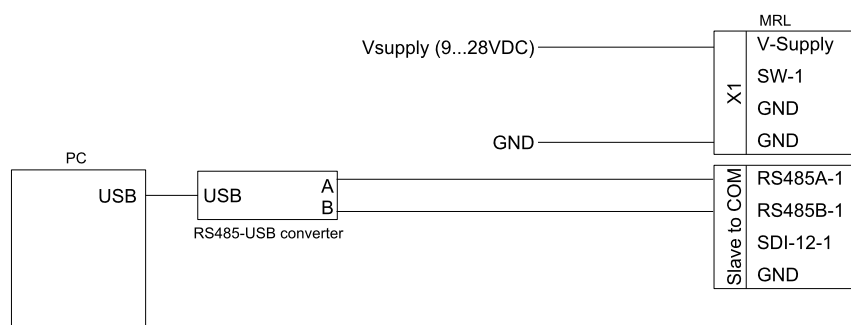

4. Start the Commander software.
5. Click on **Communication assistant** on the right-hand side of the Commander window and follow the instructions. During this procedure the communication assistant will search for connected devices. Upon successful completion, the new connection is added to the connections list (tab **Connections (F8)**).
6. Click **Connect** to establish a connection with the MRL-IE. If the connection was successful a green icon is displayed at the top-right corner of the Commander window.
7. Select the tab **Parameters (F2)** and click **Download parameters from device** on the left side of the Commander window. The complete parameter list is transferred from the sensor to your PC and displayed in the **Parameter** window.

3.2 Configure the MRL-IE

1. Navigate to **Region format** and set language and decimal character to your needs.
2. Set **Measurement Interval** in the main menu to the desired interval, e.g. 1 minute, i.e. **00:01:00**.
3. Set **Aux measurements, max. number** to **1** or higher.

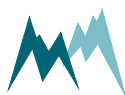

4. Add a measurement channel to the measurement table in the main menu as in the example below (see [Measurement table](#) for details).

 **EXAMPLE**
MRL-IE supply voltage as measurement channel

G Measurements, table											
	Function	Identifier	Unit	Decimals	Scale	Offset		S-TYP	S-NUM	S-MEA	S-ADD
01	Actual	Supply voltage	V	As S		0.0	Adjustment	Test	SYS	+Sup V	

5. Navigate to **Technics > RS485-1 (COM) > Output protocol** and set **Measurement output** to *Measured values push*.
 Send the parameters to the MRL-IE by clicking **Upload modified parameters to device**.



TIP

To configure the MRL-IE for your application, please read [What do I need to configure?](#) and see [Data acquisition examples](#) for various sensor connections.

3.3 View live measurements

1. Select the **Measurement (F3)** tab.
2. Make sure the MRL-IE is connected to the commander (green icon on top right corner of the Commander, see also [Establish a connection with the Communication assistant](#)). The acquired measurements are now displayed in **Measurement values** list and the **Measurement data graph**.



NOTE

For further configuration tasks like sensor connection or modem setup please go to section [Operation](#).

To learn more about the Commander software go to section [Support software Commander](#).

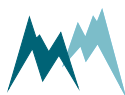

4 What can I do with it?

All data logger inputs, outputs and additional features are illustrated in [Figure 1](#).

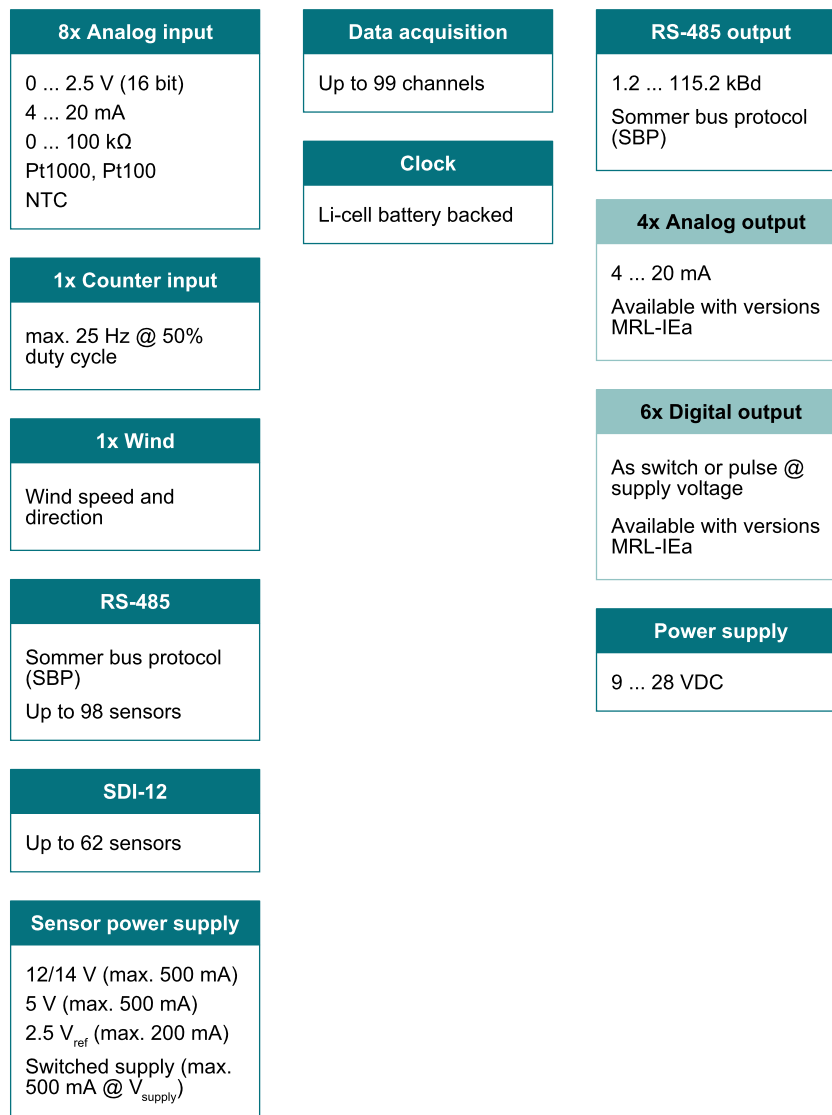
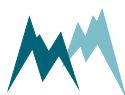

Figure 1 Data logger in- and outputs

4.1 Measurement options

The MRL-IE input extension module is designed to acquire measurements of the following sensor types:

- Analog sensor with voltage and current output
- Resistive sensors, e.g. wind vanes with potentiometer output
- Sensors with frequency output, e.g. anemometers



- Sensors with pulse output, e.g. tipping bucket rain gauge
- Digital sensors using SDI-12 and Sommer RS-485 protocols

4.1.1 Analog measurements

The analog input terminals can be configured to the following signal types:

Analog input	Measurement options
An 1 ... 8	Single ended voltage 0 ... 2.5 V Differential voltage 0 ... 2.5 V Differential voltage 0 ... 1.25 V Differential voltage 0 ... 0.311 V Differential voltage 0 ... 0.032 V Resistance <100 kΩ Resistance <3 kΩ Resistance <300 Ω Current 4 ... 20 mA PT1000 PT100 AD592 NTC-thermistor
Wind direction	Resistance (potentiometer)

Analog input terminals

4.1.2 Counts & frequency

The available counter and frequency inputs are listed below:

Analog input	Measurement options
Counter	Pulse counter, impulse length >20 ms (equals 25 Hz at 50% duty cycle), high 2.2 ... 28 V, low 0 ... 0.6 V
Wind speed	Dedicated to wind speed only, max. frequency 1 kHz

Counter and frequency input terminals

4.1.3 SDI-12 data acquisition

The MRL-IE provides one SDI-12 port for communication with SDI-12 sensors. A total of 62 SDI-12 sensors with the addresses *0...9*, *a...z* and *A...Z* can be connected.

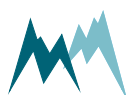

4.1.4 Serial RS-485 data acquisition

The RS-485 port of the MRL-IE provides an interface to connect digital SOMMER sensors using the Sommer Bus Protocol (SBP). A total of 98 Sensors with addresses *01...98* can be connected.

4.2 Signal output (MRL-IEa)

The analog output board offers signal conversion of the following types:

Input	Output
Voltage 0 ... 2.5 V Resistance <100 kΩ Counter Wind speed and wind direction RS-485 (SBP) SDI-12	Current 4 ... 20 mA Voltage low/high (low 0 ... 0.6 V, high 2.2 V ... V_{supply}) Impulse

All variables listed in [Measurement table](#) can thus be converted to the desired signal output.

4.3 Sensor power supply

Sensors can be powered by the voltage supply terminals listed in . Please consult the sensor manual for information on power requirements.

Output	Terminal	Maximum load
5V-Out	Supply 1	max. 500 mA
12/14V-Out	Supply 2	max. 500 mA
2.5V Reference	Reference	200 mA
Switched supply (@ data logger supply voltage)	Supply 3	max. 500 mA

Voltage supply terminals



4.4 Communication options

4.4.1 Direct connection to a PC

Communication between the MRL-IE and a PC can be established with the supplied USB to RS-485 converter. The Commander software or any terminal editor can be used to view and edit the data logger settings. Among others, the Commander provides a [Communication assistant](#) to connect to the data logger.

4.4.2 Radio connection

Sommer Messtechnik offers ultra narrow band radios for remote communication between the MRL-IE and a base station, or between one or multiple sensors and the MRL-IE as base station. See [Sommer radio devices](#) for available products.

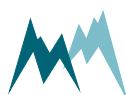

5 Versions

Art	Version
	MRL-IE (standard version)
	MRL-IEa with analog output extension



6 Specifications

Device specifications	
Power supply	9...28 VDC; Overvoltage and reverse voltage protection deep-discharge protected if used with optional battery
Power consumption	min. 0.65 mA @ 12V
Sensor supply	500 mA @ 5 V 500 mA @ 12/14 V 500 mA @ switched supply voltage
Referenced sensor supply	200 mA @ 2.5 V 100 mA @ 2.5 V (wind vane reference)
Inputs	8x Analog 0...2.5 V / 4...20 mA / Resistance; 16 bit resolution (internal 100 Ω-shunts) 1x Counter (max. 25 Hz @ 50% duty cycle) 1x Wind speed (frequency) 1x Wind direction (potentiometer) 1x RS-485 1x SDI-12 as primary/master (version 1.3) All analog inputs are equipped with overvoltage fine protection up to 36 V
Outputs	1x RS-485 (9600...115200 Baud), Modbus RTU 1x SDI-12 as secondary/slave (version 1.3) 4x Analog current output (MRL-IEa) 6x Switched output @ supply voltage (can be used as pulse output by adding a pull-down resistor)
Number of recorded variables	max. 99
Measurement interval	2 s ... 12 h
Statistics interval	10 s ... 12 h
Operating temperature	-40...60 °C (-40...140 °F)
Storage temperature	-40...60 °C (-40...140 °F)
Protection rating	IP67
Lightning protection	Integrated protection against indirect lightning with a discharge capacity of 6 kA Ppp

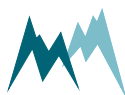

Device specifications

Housing material	Aluminium, powder coated
Size L x W x H	180 x 150 x 90 mm (7.09 x 5.91 x 3.54 inch)
Weight	1.48 kg (3.26 lb)

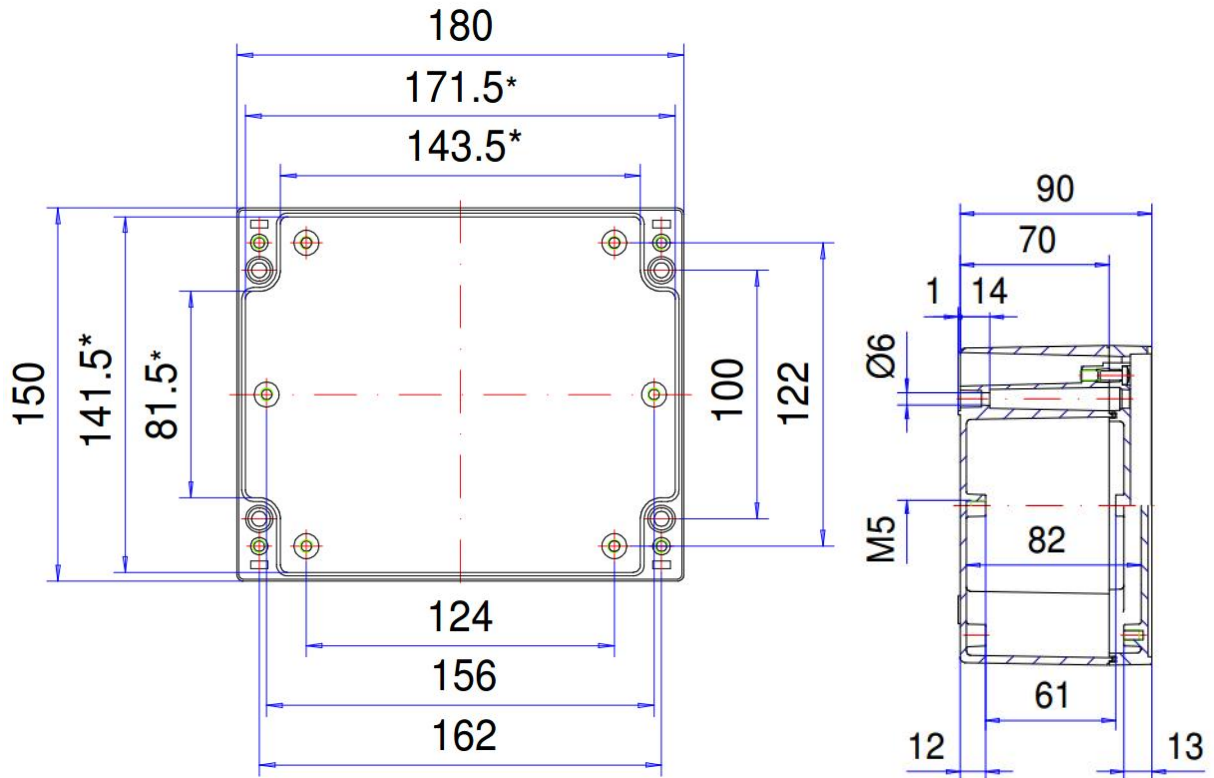

Dimensions MRL-IE



7 Components

7.1 Terminals

The pin-layout of the MRL-IE is shown in Figure 2 and the terminals are listed in the table below.



ATTENTION Do not connect voltages higher than 30 V to any terminal! Excess voltages can impair the functioning of the MRL-IE, destroy the device and may lead to injuries.

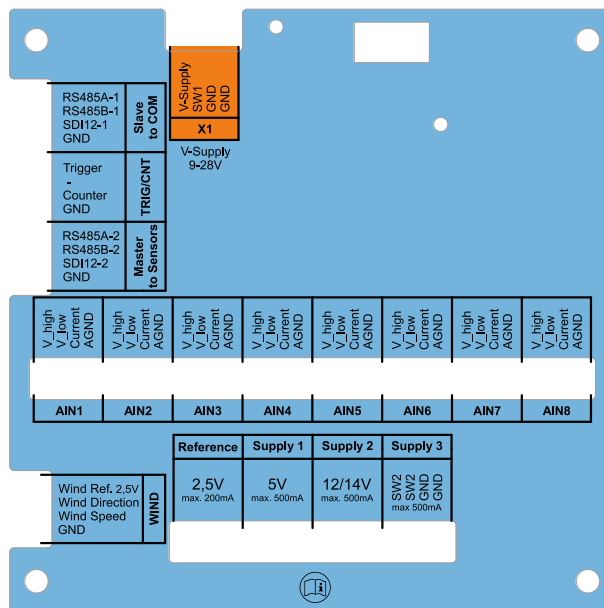
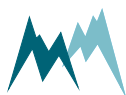

Figure 2 Connection terminals of MRL-IE

Group	Pin	Description
X1	V-Supply	Supply voltage (+)
	SW1	inactive
	GND	Ground of SW1
	GND	Supply voltage (-)



Group	Pin	Description
Slave to COM	RS485A-1	RS-485 A
	RS485B-1	RS-485 B
	SDI12-1	SDI-12 Slave
	GND	Ground of SDI12-1
TRIG/CNT	Trigger	Trigger input
	-	not assigned
	Counter	Counter input
	GND	Ground
Master to Sensors	RS485A-2	RS-485 A Sensor input
	RS485B-2	RS-485 B Sensor input
	SDI12-2	SDI-12 Master
	GND	Ground of SDI12-2
WIND	2.5V	2.5 V reference voltage output
	Wind Dir	Wind direction (potentiometer) input
	Wind Speed	Wind speed input
	GND	Ground
AIN1 ... AN8	V_high	High voltage input
	V_low	Low voltage input
	Current	Current input
	AGND	Analog ground
Reference	2.5 V max. 200 mA	2.5 V sensor supply
		2.5 V sensor supply
		2.5 V sensor supply
		2.5 V sensor supply



Group	Pin	Description
Supply 1	5 V max. 500 mA	5 V sensor supply
		5 V sensor supply
		5 V sensor supply
		5 V sensor supply
Supply 2	12/14 V max. 500 mA	12/14 V sensor supply
		12/14 V sensor supply
		12/14 V sensor supply
		12/14 V sensor supply
Supply 3	SW2	Switched sensor supply
	SW2	Switched sensor supply
	GND	Ground
	GND	Ground

7.2 Analog output terminals (MRL-IEa)

The pin-layout of the analog output extension is shown in [Figure 3](#)



ATTENTION Do not connect voltages >30 V to any terminal! Excess voltages can impair the functioning of the MRL-IE, destroy the device and may lead to injuries.

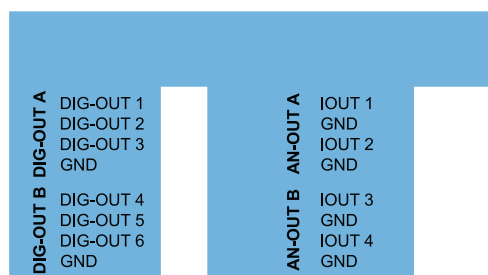
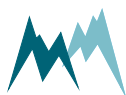

Figure 3 Connection terminals of the analog output extension

Group	Pin	Description
DIG-OUT A	DIG-OUT 1	Digital output (@ data logger supply voltage)
	DIG-OUT 2	Digital output (@ data logger supply voltage)
	DIG-OUT 3	Digital output (@ data logger supply voltage)
	GND	Ground
DIG-OUT B	DIG-OUT 1	Digital output (@ data logger supply voltage)
	DIG-OUT 2	Digital output (@ data logger supply voltage)
	DIG-OUT 3	Digital output (@ data logger supply voltage)
	GND	Ground
AN-OUT A	IOOUT 1	Analog current output (4 ... 20 mA)
	GND	Ground
	IOOUT 2	Analog current output (4 ... 20 mA)
	GND	Ground
AN-OUT B	IOOUT 3	Analog current output (4 ... 20 mA)
	GND	Ground
	IOOUT 4	Analog current output (4 ... 20 mA)
	GND	Ground



8 Installation

8.1 Where should I install the MRL-IE?

The MRL-IE has been designed for applications in harsh environments. With its IP-67 protection rating it can be installed directly at the measurement facility.

If additional control and acquisition devices are used, the MRL-IE may also be mounted in a suitably sized cabinet.



ATTENTION If the MRL-IE is installed outdoors, make sure the device cover and cable glands are tightened firmly and that unused glands are replaced with watertight blanking plugs (see accessories list in [Unpacking](#)).

8.2 Required tools and equipment

Prepare the following tools and equipment to install the MRL-IE:

- 1x 5 mm Philips or flat screw driver (depending on mounting bolts)

8.3 How do I install the MRL-IE?

8.3.1 Mounting

The MRL-IE can be mounted to a mounting plate of an electrical cabinet or any other back-plate with four M5 cylinder head screws with hexagon or torx socket or M4 cylinder head screws with simple or cross slot. The mounting holes can be accessed by removing the cover strips on both sides of the MRL-IE (see figure below).

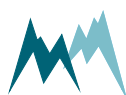



8.3.2 Power supply

The MRL-IE can be powered with a 9...28 VDC power supply connected to terminal X1. It consumes a minimum of 0.65 mA at 12 V; the actual consumption depends on the connected sensors and their power requirements.

8.3.3 Signal cables

Please consider the maximum cable lengths for the applied transmission protocol:

Protocol	Max. cable length
SDI-12	~60 m (depending on wire cross section and number of sensors)
RS-485	~300 m



NOTE Cable lengths longer than 60 m require a heavier gauge wire if the power supply drops below 11 V.

The analog outputs of the optional analog output board (included in the MRL-IEa) accept an electrical load of max. 250 Ω at 9 V, 380 Ω at 12 V and 900 Ω at 24 V (including wires, shunt resistor, etc). The loads on the digital outputs are restricted to 69 ... 10'000 Ω at 9 V, 92 ... 10'000 Ω at 12 V and 185 ... 10'000 Ω at 24 V.

8.3.4 Lightning protection

If the underground at the measurement site permits sufficient current dissipation it is strongly recommended to equip the sensor support or mast with properly dimensioned lightning protection. Consult an expert for advice.

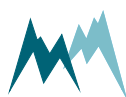

The MRL-IE is protected against overvoltage. If a data logger is mounted to the mast, its ground lug must be properly connected to earth ground.



9 Operation

9.1 Status of LEDs

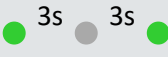
The LEDs on the front panel of the MRL-IE indicate the device status. The meaning of each LED and its flashing sequence are described below.

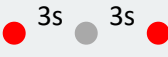
Active	Description
	Device in sleep mode
	Continuous measurements active
Error (only during active measurements)	Description
	No error
	Error on last measurement

9.2 How to open the data logger housing

The data logger has a waterproof design which requires the sensors, SIM card and MicroSD card to be connected internally.



ATTENTION To avoid any damage disconnect the power supply before opening the housing!

To open the housing remove the cover strips on both sides of the data logger and loosen the four bolts with a Philips or flat-head screwdriver. Then, remove the lid by turning it carefully upside down. Be careful not to strain any signal wires.

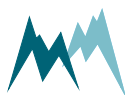

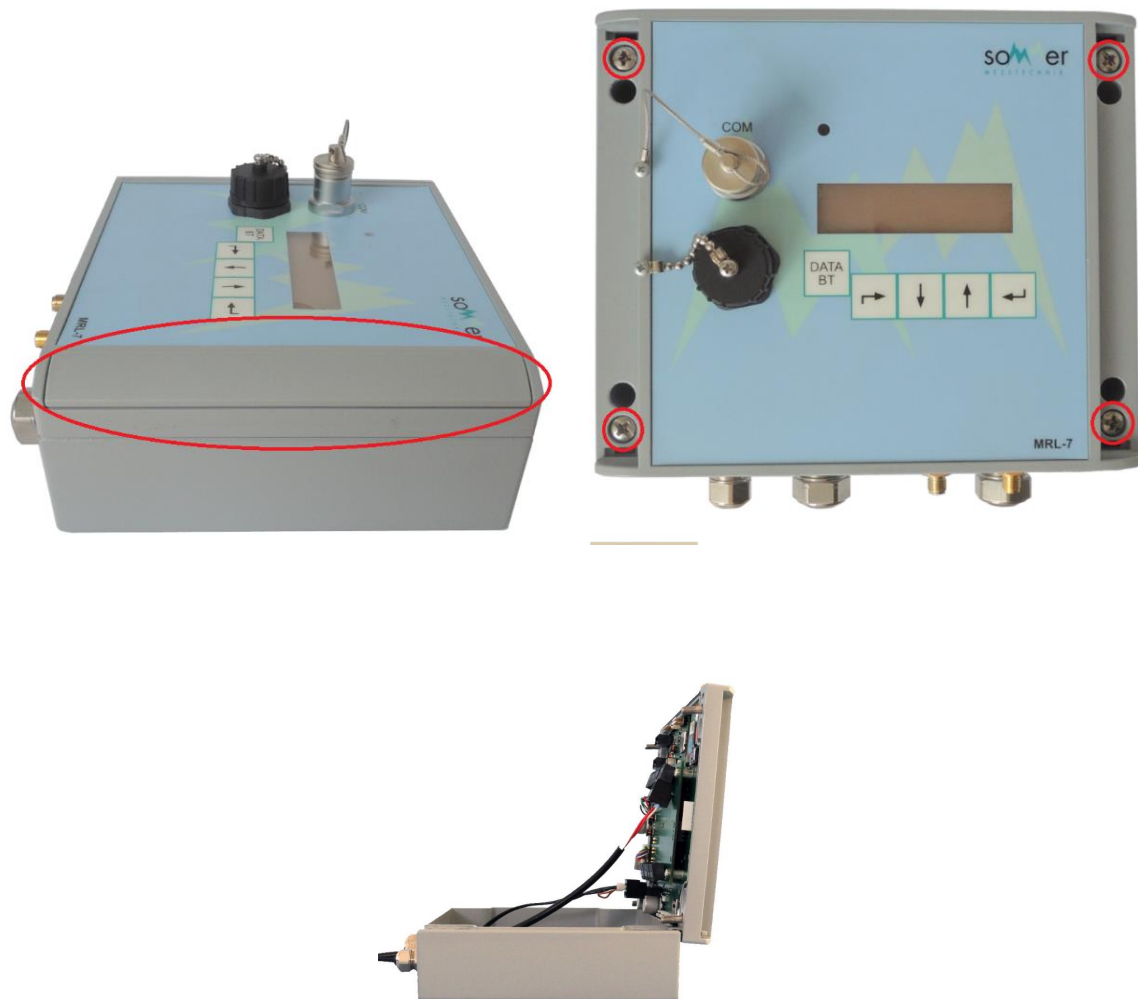

Figure 4 Open the MRL-IE housing



ATTENTION

Before closing the data logger make sure that the rubber seal is not broken and firmly sitting in its groove!

When closing, tighten diagonally positioned screws step by step!

9.3 How to use the spring clips

To connect a sensor to the MRL-IE, 2- or 4-pin spring clips as shown in [Figure 5](#) are used.

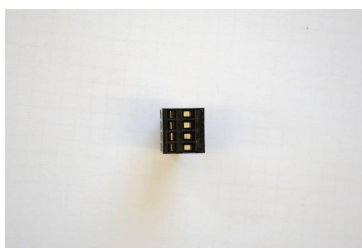
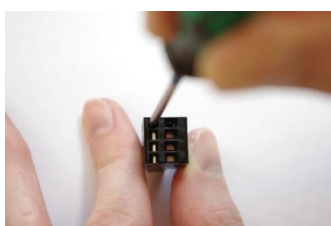
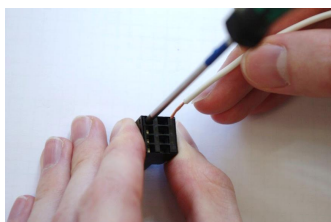

Figure 5 4-pin spring clip

After removing the spring clip from the data logger, the sensor wires are connected in the following way:



Push a 2-mm flat-head screwdriver into the spring slot to open the connection terminal.



Insert the wire into the connection terminal.

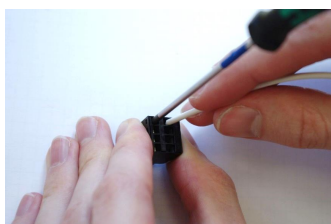

Make sure the wire is inserted down to the bottom of the connection terminal.

ATTENTION Make sure the spring clip connects on the bare wire and not on the wire insulation!

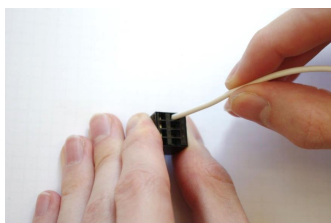

Pull out the screwdriver and verify that the wire is fixed firmly.

9.4 How to connect a sensor

To connect a sensor to the MRL-IE follow the steps described below:

1. Open the housing as describes in [How to open the data logger housing](#)
Feed the sensor cable through the cable gland.
2. Strip 10 ... 20 cm of the cable insulation. The insulated cable should protrude max. 1 cm into

the housing.

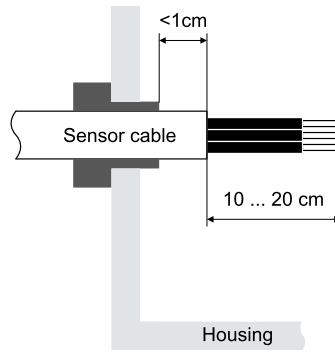

3. Connect the cable wires to the specified terminals (see [Terminals](#)). For handling the spring clips see [How to use the spring clips](#).
4. After closing the data logger, carefully tighten the cable glands.

9.5 How to wire analog outputs

Only applicable to MRL-IEa. The 4 ... 20 mA outputs can be wired to any data acquisition device that accepts current or voltage inputs. The latter may require a precision shunt resistor – 100 Ω is generally adequate – to convert the current into a voltage signal. The diagram below shows an example of the wiring between the MRL-IEa and a data logger. See [Analog outputs \(MRL-IEa only\)](#) for configuration of the analog outputs.

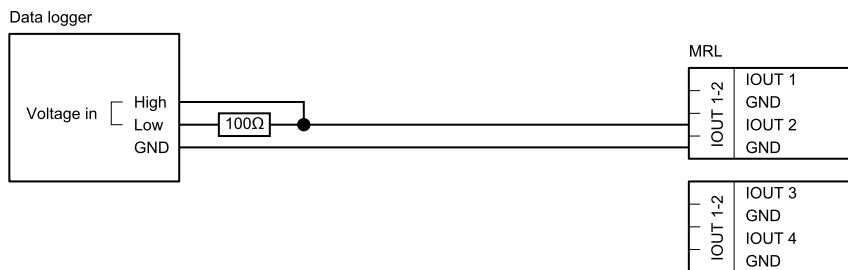

Figure 6 Wiring of an analog output to a data logger

9.6 How to wire digital outputs

Only applicable to MRL-IEa. The digital outputs can be wired to any data acquisition device that accepts voltage and/or counter inputs. The diagram below shows an example of the wiring between the MRL-IEa and a data logger. See [Digital output settings \(MRL-IEa only\)](#) for configuration of the digital outputs.



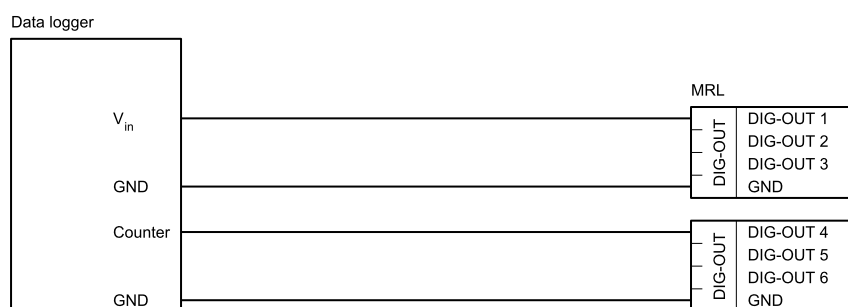

Figure 7 Wiring of a digital output to a data logger

9.7 How to set the clock

The time of the MRL-IE can also be synchronized manually by clicking [Set device time](#) in the Commander [Parameters \(F2\)](#) tab.



ATTENTION If the internal lithium button cell battery is replaced, the current device time is lost and needs to be re-synchronized!

9.8 How to replace the internal lithium battery

The 3V lithium button cell battery of type CR1225 supplies the internal clock if the MRL-IE is not powered. Perform the following steps to replace the battery:

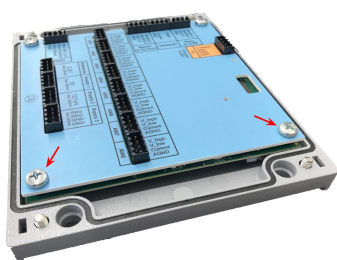

Unpower the device, open it and loosen the two bolts on the lithium battery side of the print.



Gently lift the label-sheet with your fingertips.

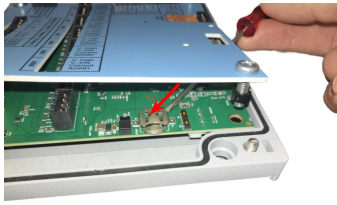

Push the lithium button cell battery with a small screwdriver out of its clip.

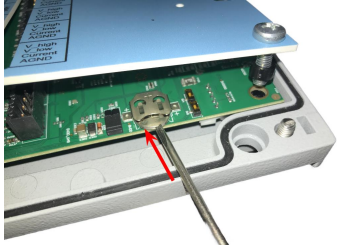

Insert the new battery, + is facing upwards, with your finger tips or a small screwdriver into its clip.
Gently tighten the bolts of the prints and close the device housing.

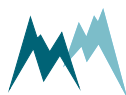

10 Maintenance

The MRL-IE does not require any special maintenance other than the occasional replacement of the supply battery of the MRL-IE. The lithium button cell battery lasts approx. 10 years if the MRL-IE is not powered, and generally does not require replacement with a powered device.

10.1 Calibration

Re-calibration of the AD-converters strongly depends on the handling of the data logger, its duty time and the demands on accuracy of the acquired measurements. Generally, re-calibration is required after approx. 10 years of operation. Please contact Sommer Messtechnik for this service.

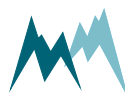

11 Support software Commander

11.1 Software features

The Commander is a multipurpose software tool to configure and operate any Sommer Messtechnik device. It offers the following functions:

- Communication with Sommer Messtechnik sensors and data loggers via serial connection, modem, socket, IP-call and Bluetooth®
- Management of connections and stations
- Configurations of sensors and data loggers
- Live data monitoring and storage
- Data management including download from data loggers and transmission to MDS (Measurement Data server)
- Terminal window to check data transfer and to access device settings directly

11.2 System requirements

The Commander software supports 32- and 64-bit versions of Windows 7 SP1, Windows 8, Windows 8.1, Windows 10 and Windows 11.

For correct operation Microsoft® .NET Framework 4.5 or later must be installed.

11.3 Installation of Commander

Follow the steps below to install the Commander software:

1. Plug the USB stick shipped with the device into your PC.
2. Double-click the `commander.msi` installer file on the USB drive.
3. Click **Next** on the pop-up window

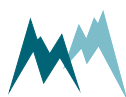



4. Read the instructions and click [Next](#)

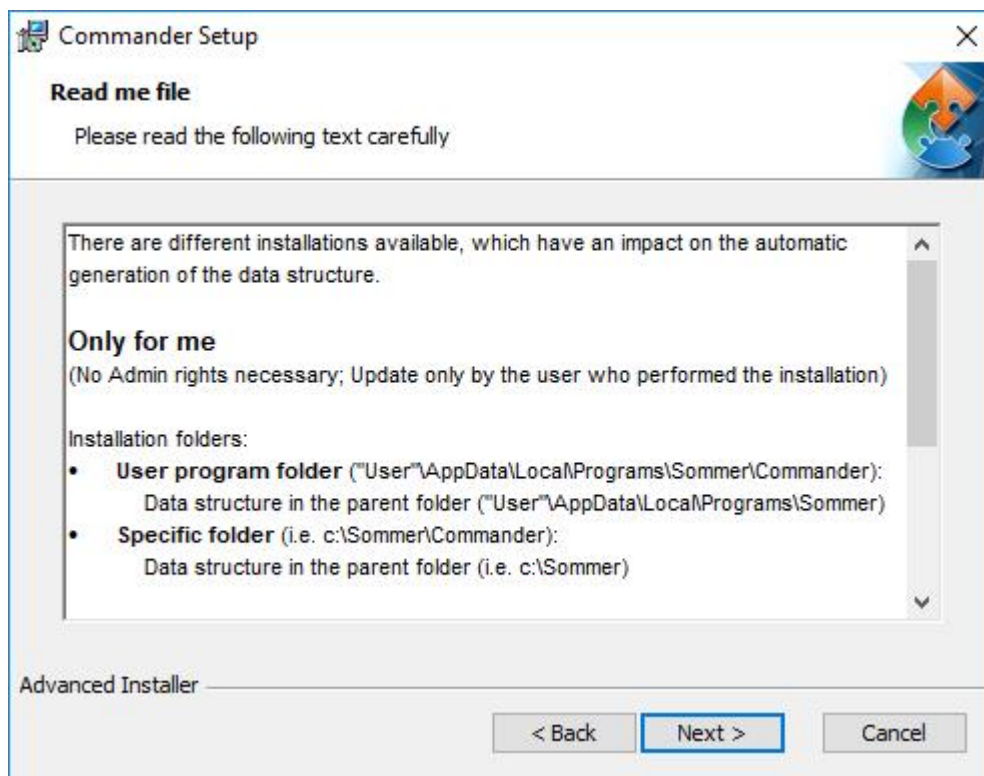

5. Select the installation type and click [Next](#)

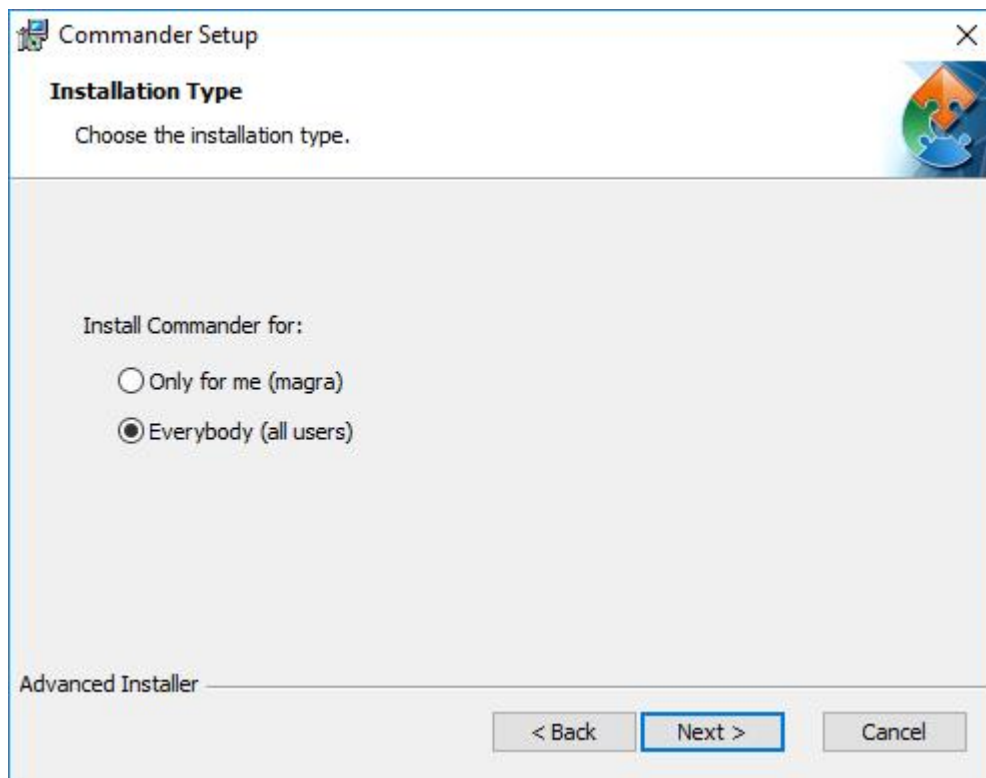

NOTE

Two installation types are available. Depending on the selection, the access rights and the folder structure differ:

Only for me

No admin rights are required. Updates are only available to the user who installed the software.

Installation folders:

- User program folder:
Users\User\AppData\Local\Programs\Sommer\Commander
- Data structure:
Users\User\AppData\Local\Programs\Sommer

- Specific folder (default):
C:\Sommer\Commander
- Data structure (default):
C:\Sommer

Everybody

Admin rights are required. Updates may only be performed by system administrators.

Installation folders:

- Standard program folder:
Program Files (x86)\Sommer\Commander

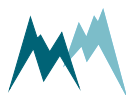

 Data structure:
 Users\Public\Public documents\Sommer

- Specific folder (default):
 C:\Sommer\Commander

Data structure (default):
 C:\Sommer

6. Select the installation directory and click **Next**.

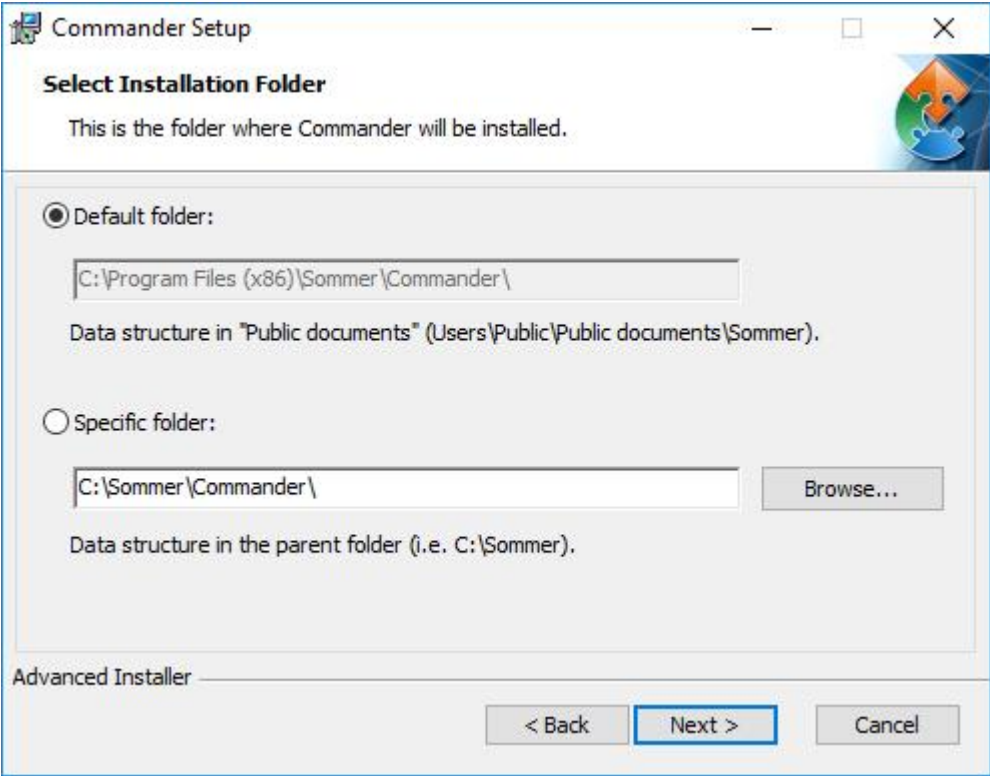

7. Select the features to be installed and click **Next**.

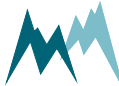

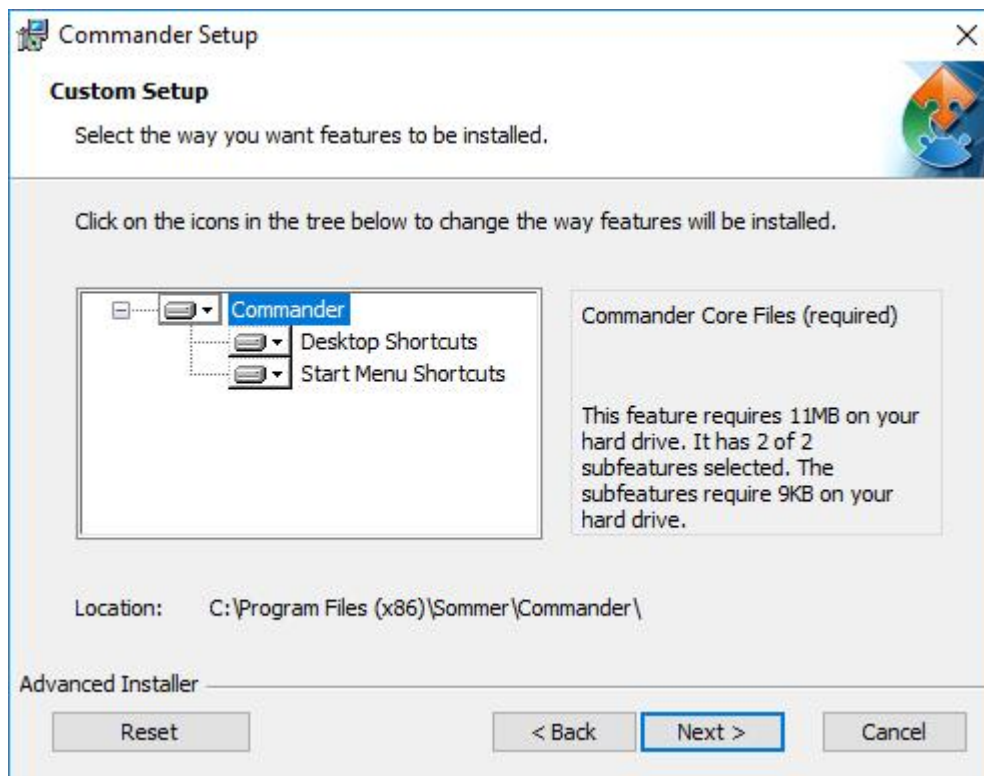

8. Click **Install** to start the installation.

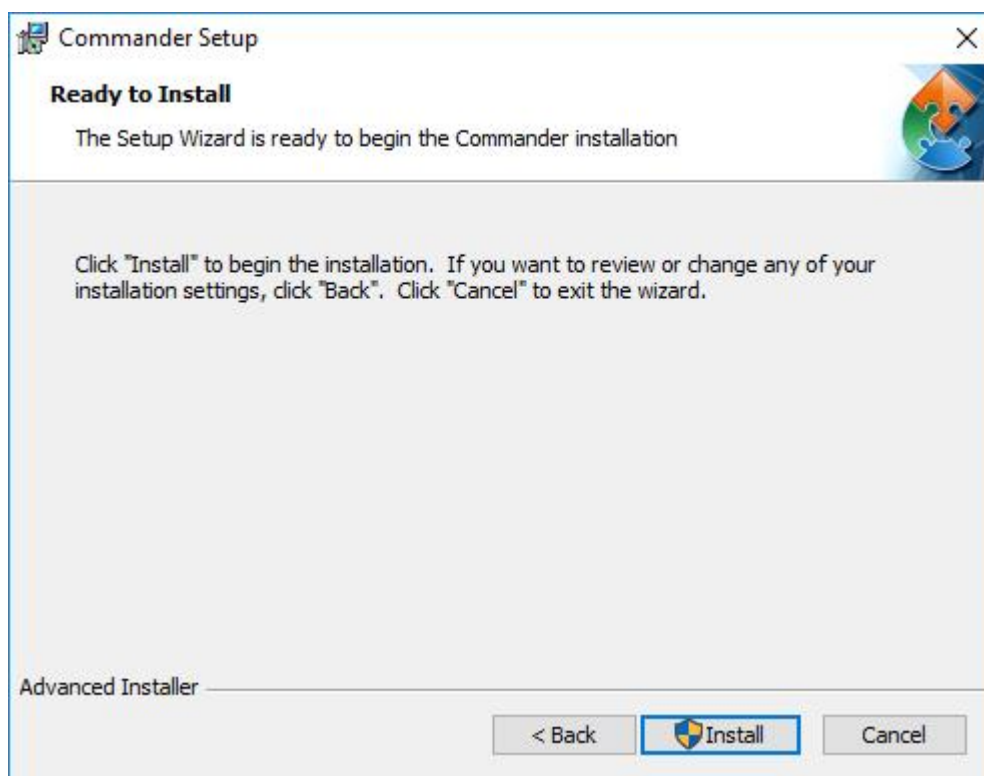

9. Click **Finish** to complete the installation.

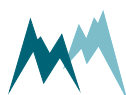

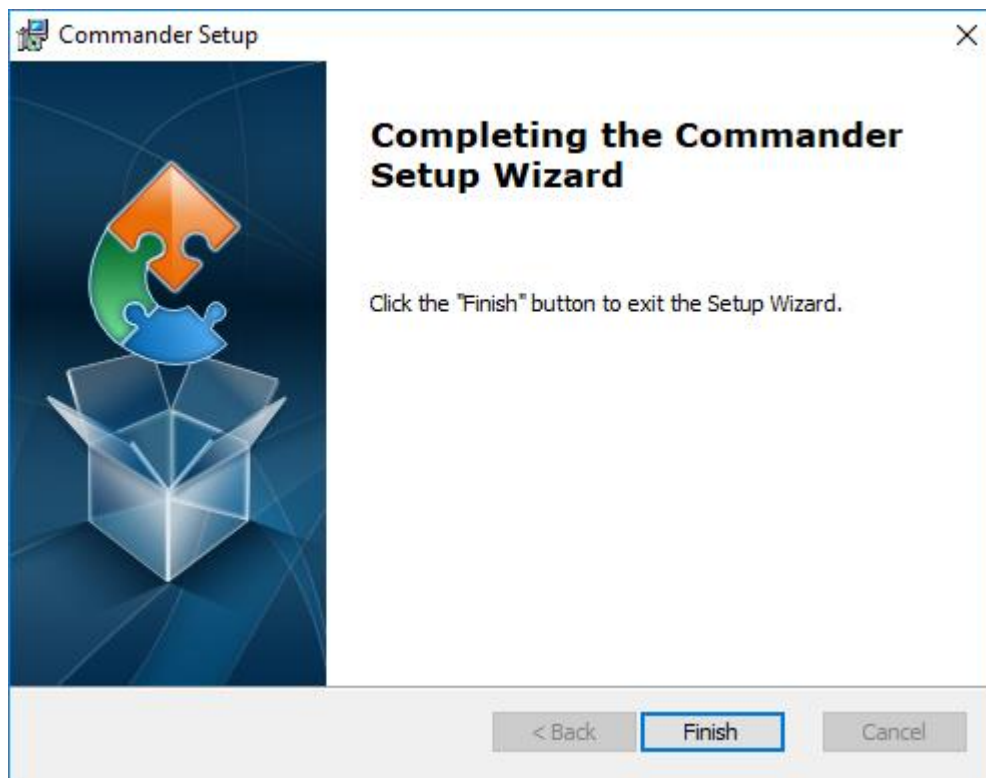

11.4 Change authorization

To prevent unintended changes of parameters in the **Technics** menu authorization is generally set to **Normal**. Parameter modifications in **Technics** are enabled by switching the authorization level to **Expert** as described below:

1. On the upper tab bar click on **Options** and select **Common**.
2. In the Options window select authorization **Expert** and click **OK**.

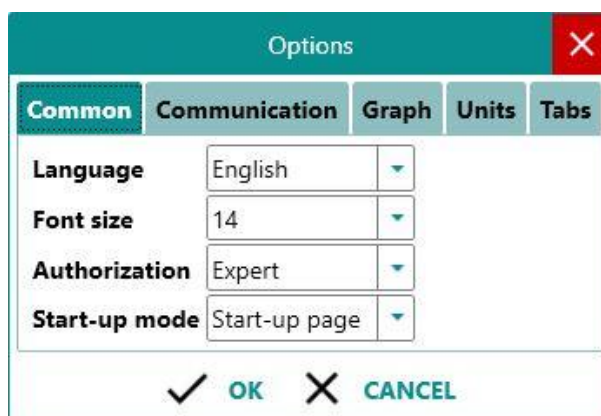

11.5 Working with connections

11.5.1 Establish a connection with the Communication assistant

1. Install the Commander support software as described in [Installation of Commander](#).
2. Connect the device to your PC.
3. Start the Commander software on your PC.
4. Click on [Communication assistant](#) on the right-hand side of the Commander window and follow the instructions. During this procedure the communication assistant will search for connected devices. Upon successful completion, the new connection is added to the connections list (tab [Connections \(F8\)](#)).
5. In the [Communication](#) section at the right-hand side of the Commander window select Mode [Connection](#) and the previously created connection from the drop-down list.
6. Click [Connect](#) to establish a connection with the MRL-IE. If the connection was successful a green icon is displayed at the top-right corner of the Commander window.

To view the settings of the connected device or to read the current measurements, follow the steps described in [Download setup](#) and [Record measurements](#).

11.5.2 Establish a connection manually

1. Install the Commander support software as described in [Installation of Commander](#).
2. Connect the device to your PC.
3. Start the Commander software on your PC.
4. Select the required connection in the [Connections](#) list of the [Connections \(F8\)](#) tab and click [Connect](#). If the connection was successful a green icon is displayed at the top-right corner of the Commander window.
If you don't have the required connection available in the [Connections](#) list, create a new connection as described in [Create a new connection](#).

To view the settings of the connected device or to read the current measurements, follow the steps described in [Download setup](#) and [Record measurements](#).

11.5.3 Create a new connection

1. Select the [Connections \(F8\)](#) tab in the Commander.
2. Click [New connection](#).
3. In the section [Connection settings](#) enter a name of the new connection, e.g. *Serial-com1-9600*, and the connection type, e.g. *Serial connection*.

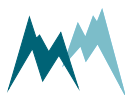

- Enter the required information for the selected connection type.
If your MRL-IE is wired to your PC with a RS-485 to USB converter cable, select the port where the device is connected and select a Baud rate of 9800.

11.6 Working with stations

11.6.1 Create a station with the Communication assistant

In order to manage several data loggers, to connect to a data logger via IP-call and to download data, stations can be created in the Commander software. To view a list of all stations select the tab [Stations \(F7\)](#).

Perform the following steps to create a new station with the [Communication assistant](#):

- Click on [Communication assistant](#) in the Commander-window

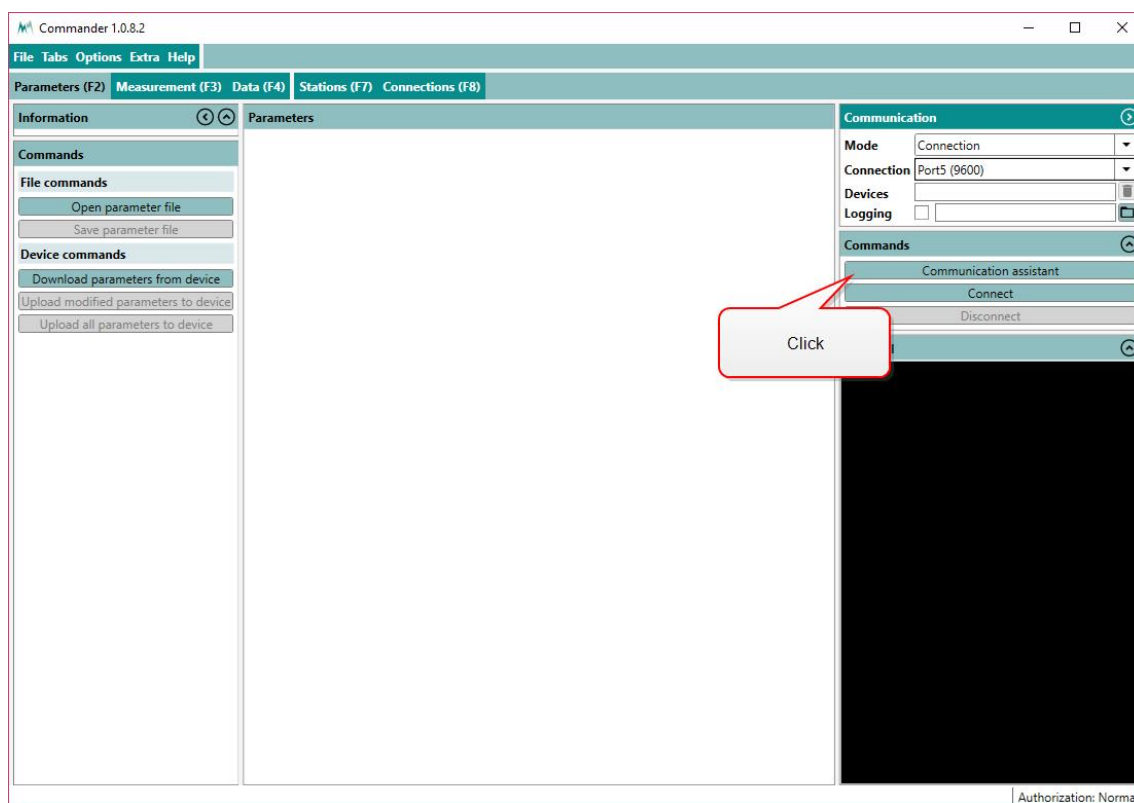

- In the pop-up window choose the required connection and click [Next](#).

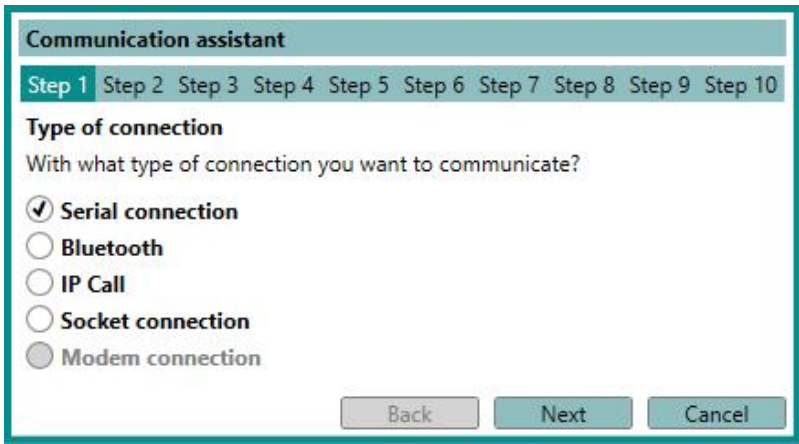

3. Verify that the MRL-IE is connected to your PC and a power supply. Click [Next](#).



4. Select [Logger \(115200 Bd\)](#) and click [Next](#).



5. Select [Scan ports](#) and click [Next](#).

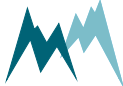

Communication assistant

Step 1 Step 2 Step 3 **Step 4** Step 5 Step 6 Step 7 Step 8 Step 9

Serial connection: Connection

Do you want to communicate with an existing or new connection?

Baud rate 115200

Existing connection

Connection Port9 (115200) ▼

New connection

Select port 09 ▼

Scan ports

Back Next Cancel

- The Commander now scans all available ports.

Communication assistant

Step 1 Step 2 Step 3 Step 4 **Step 5** Step 6 Step 7 Step 8 Step 9

Serial connection: Scan device

All available serial ports are sequentially scanned for a device.
When the first device is found, the procedure is stopped.

Scan ports

Port: 11

4/7

Back Next Cancel

- Adopt the *Name* provided by the communication assistant. Click **Next**.

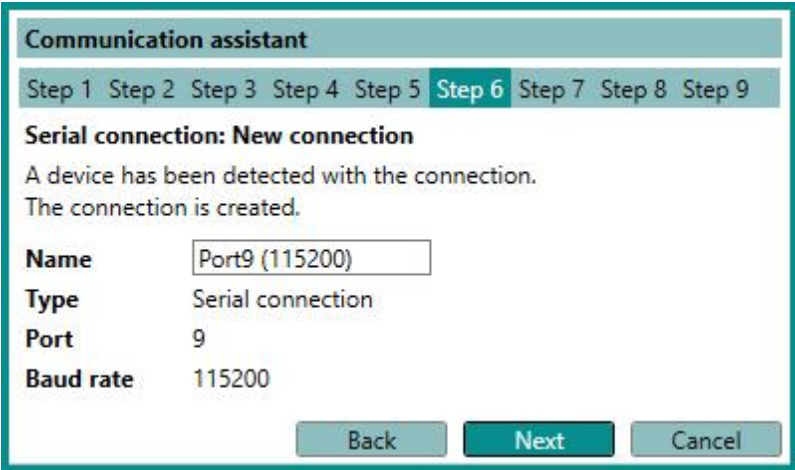

8. The Commander now scans the selected port for connected devices.

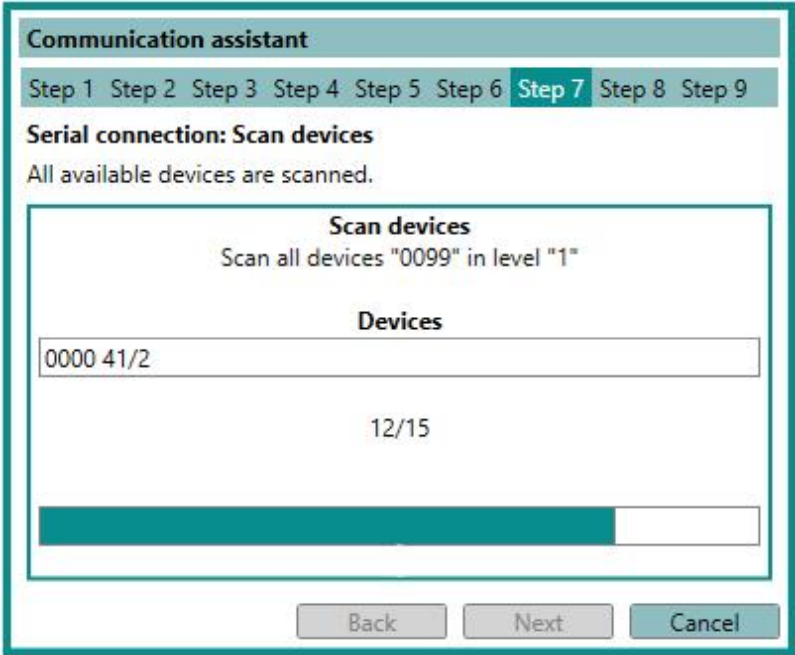

9. Adopt the *Name* of the new station or enter a new name. Click *Next*.



Communication assistant

Step 1 Step 2 Step 3 Step 4 Step 5 Step 6 Step 7 **Step 8** Step 9

New station

No matching station has been found.
Changes of the station number are performed on the device as well.

Station ID 05170012

Station number 05170012

Name RQ-ADMS

Devices ▾ 0000 MRL-7

Do you want to save the station?

Back Yes No

10. A new station has now been created. Click [Finish](#).

Communication assistant

Step 1 Step 2 Step 3 Step 4 Step 5 Step 6 Step 7 Step 8 **Step 9**

Station selected

The station has been selected and can now be used.

Back Next Finish

11. The newly created station can now be selected in the [Communication](#) section of the Commander. Click [Connect](#) to activate the connection to your device.

11.6.2 Create a station manually

In order to manage several data loggers, to connect to a data logger via IP-call and to download data, stations can be created in the Commander software. To view a list of all stations select the tab [Stations \(F7\)](#).

Perform the following steps to create a new station:

1. In the tab-menu [Stations \(F7\)](#) click [New station](#).
2. Under [Station settings](#) enter the [Station number](#) and [Sommer ID](#). By default both settings are set to the device's serial number (visible on the MRL-IE housing).
3. Select the [Connections](#) used for the station. Multiple selections are possible; the default connection can be selected by ticking the circular field.
4. Depending on the connection type, enter the additional information, e.g. [Address](#) for a Bluetooth connection or [IMSI number](#) for an IP call.

5. Enter the settings for **Data** management. When data are downloaded from a connected MRL-IE they are stored in an archive-file by default. Each archive-file contains the data of a year or month, as selected in **Archive type**. Selection **None** will save all data in one file. The default location for data files is C:\Users\Public\Documents\Sommer\Data\.
6. Save the newly created station with the button **Save station**.

11.7 Working with measurements

11.7.1 Poll continuous measurements

1. Establish a connection to your device as described in **Working with connections**.
2. Download the setup of your device as described in **Download setup**.
3. Select the **Measurement (F3)** tab.
4. In the **Commands** section click **Start polling measurement**.
5. Select the option **Polling with measurements**. Now, the Commander will trigger measurements of the MRL-IE without any delays between measurements. The results are displayed **Measurement values** and plotted in the **Measurement data graph**.
6. To finish polling mode click **Stop polling**.

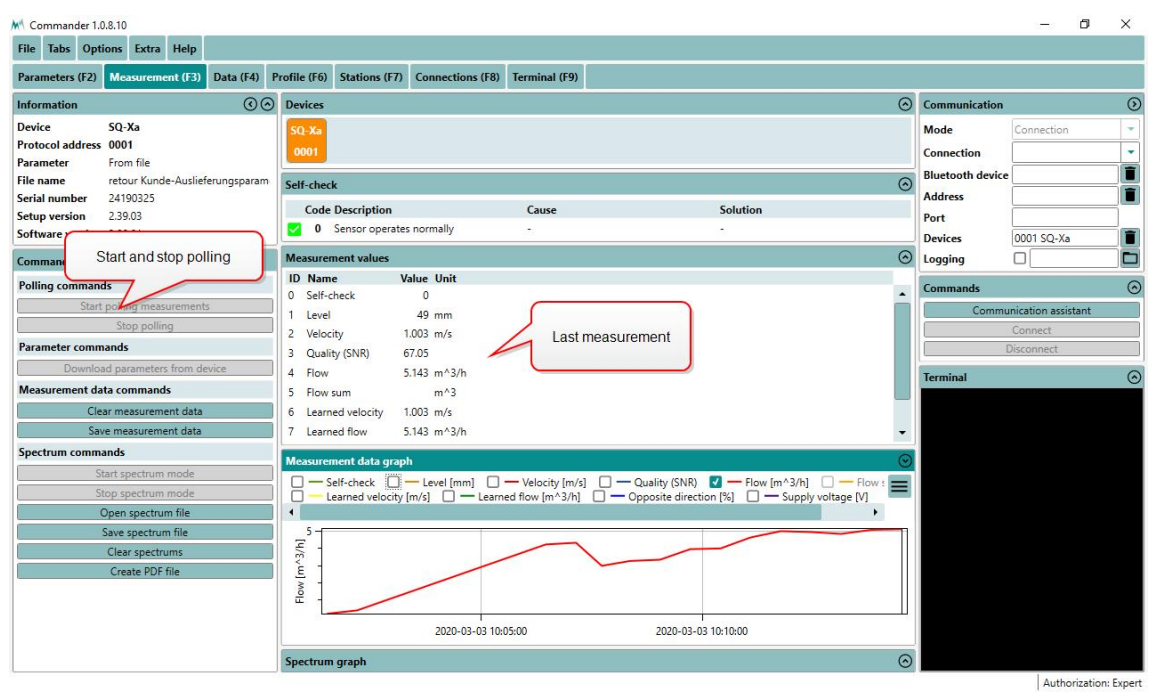

NOTE The polling mode stops automatically after 30 minutes.



11.7.2 Record measurements

1. Establish a connection to your device as described in [Working with connections](#).
2. Download the setup of your device as described in [Download setup](#).
3. Select the [Measurement \(F3\)](#) tab.
4. Make sure that [Measurement output](#) is set to *Measured values push* or *Storage values push*.
5. If the connection with your device is active, the data will now be displayed in the measurement table and updated at the interval specified in the setup. Also, the incoming data strings are displayed in the [Terminal](#).
6. Click [Save measurement data](#) in the [Commands](#) section to save the recorded measurements. The data are saved as a *.csv file in the SommerXF format.

11.8 Working with data

11.8.1 View live data

Follow the steps below to view live data acquired from your device:

1. Establish a direct or remote connection with the MRL-IE using the Commander. Use an existing Commander-connection or -station if available.
2. In the [Parameters \(F2\)](#) tab download the parameters of the MRL-IE.
3. Now, there are two options to view the measurement data:
 1. If [Measurement output](#) is set to *Measured values push* or *Storage values push*, data are displayed in the [Measurement \(F3\)](#) tab in the specified measurement interval.
 2. Open the [Measurement \(F3\)](#) tab and click [Start polling measurements](#). With this option measurements are triggered in the fastest possible sequence and the results are displayed instantly. This measurement mode can be stopped by clicking [Stop polling](#), or it is finished automatically after 30 minutes.

11.9 Working with setups

11.9.1 Download setup

1. Establish a connection to your device as described in [Working with connections](#).
2. Select the [Parameters \(F2\)](#) tab in the Commander software.
3. In the [Commands](#) section click [Download parameters from device](#).



The Commander now downloads the setup currently active on the MRL-IE. This may take some time if you are downloading the setup for the first time to your PC. Consecutive downloads of a setup with the same version number will be faster as the parameter structure is already available.

You can now save the setup file by clicking [Save parameter file](#), or edit the settings as described in [Edit setup](#).



TIP Save the setup on your PC before you make any changes!

11.9.2 Open a setup file

1. Start the Commander on your PC and connect to your MRL-IE either directly with the USB to RS485 isolated converter cable or, if available, the optional Bluetooth connection.
2. Open the [Parameters \(F2\)](#) tab and click [Open parameter file](#). Select the required file (extension .xml or .xmla).
3. Verify the new settings and click [Upload all parameters to device](#). After completion the new settings are active on your data logger.

11.9.3 Edit setup

1. Open the setup file as described in [Open a setup file](#) or download it from your device as described in [Download setup](#).
2. Adapt the values of the settings in question and press Enter after each. After you have changed a value, its text box will turn red.



NOTE If you have entered a value outside the data range of the setting, it will be forced to the next valid value! The valid range of each setting is listed in the [Parameter definitions](#).

3. After you have adapted all required settings save the setup file and/or upload the setup to your device by clicking [Upload modified parameters to device](#).
Once the setup has been saved or uploaded, the modified red text boxes will turn white again, indicating that the settings have been saved/applied.

11.9.4 Upload new setup file

1. Establish a connection to your device as described in [Working with connections](#).
2. Select the [Parameters \(F2\)](#) tab.

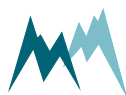

3. Download the setup currently on the MRL-IE as described in [Download setup](#) and save it by clicking [Save parameter file](#). This step is recommended to have the latest setup available for documentation.
4. Click [Open parameter file](#) and select the required setup file (*.xlm) on your PC.
5. Click [Upload all parameters to device](#). This transfers the current setup to the MRL-IE.
6. To verify the correct upload click [Download parameters from device](#). This will display the present setup of the MRL-IE.

11.10 Update firmware

1. Connect the MRL-IE to your PC with the USB to RS485 isolated converter cable.
2. Make sure no connection is active in the Commander (no green icon at the top-right corner).
3. Click on the menu item [Extra](#) and select [Start Programmer](#).
4. Select the firmware file (*.hex) provided by SOMMER Messtechnik. Make sure the file is stored on your PC and not on a USB or network drive.
5. Choose the COM-port the data logger is connected to and a Baud-rate of 57'600.
6. Perform the following three steps in short sequence:
 - Click [Program](#)
 - Unpower the data logger
 - Wait 3...5 seconds to enable full activation of the bootloader and a correct restart (capacitors must be discharged, and if the device had been in sleep mode, this can take some time)
 - Repower the data logger

The firmware currently present on the data logger is now erased and the new one copied to the data logger. During the update process the pop-up window may show the following messages:

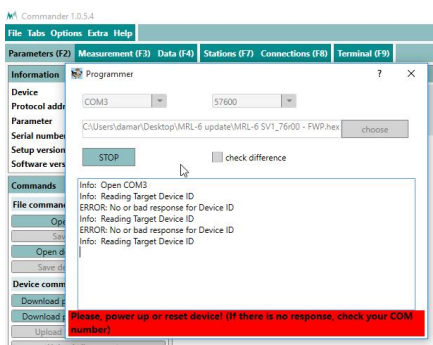

The programmer is not ready; power needs to be on.

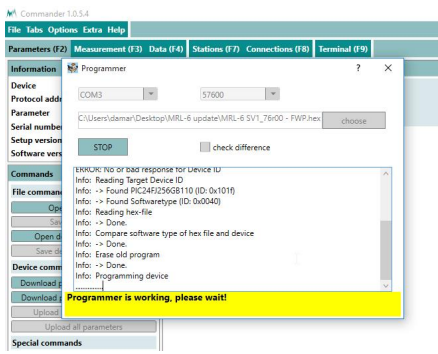

The programmer is active.

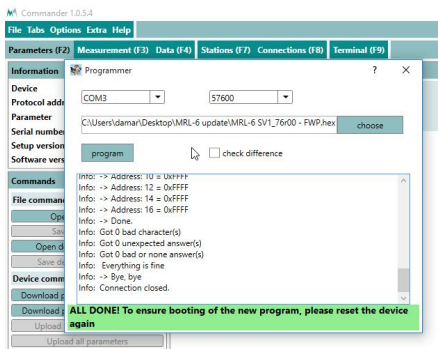

The firmware update has finished.

7. Close the programmer-window as soon as the firmware update has finished.
8. Switch off and repower the data logger again.
9. Open the **Parameters (F2)** tab.
10. Click **Download parameters from device**. The download of the new parameter list might take a few minutes as the parameter structure may need to be downloaded as well. After completion the new firmware and setup versions will be displayed in the **Information** section.

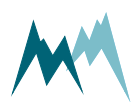

12 Configuration of the MRL-IE

The MRL-IE can be configured with one of the following tools:

- Configuration with Commander support software
- Configuration with a terminal program

12.1 Configuration with Commander support software

Follow the steps below to modify the configuration parameters of the MRL-IE:

1. Establish a connection between your PC and the MRL-IE.
2. Select the tab **Parameters (F2)** and click **Download parameters from device**. The complete parameter list is transferred from the sensor to your PC and displayed in the Parameter window.

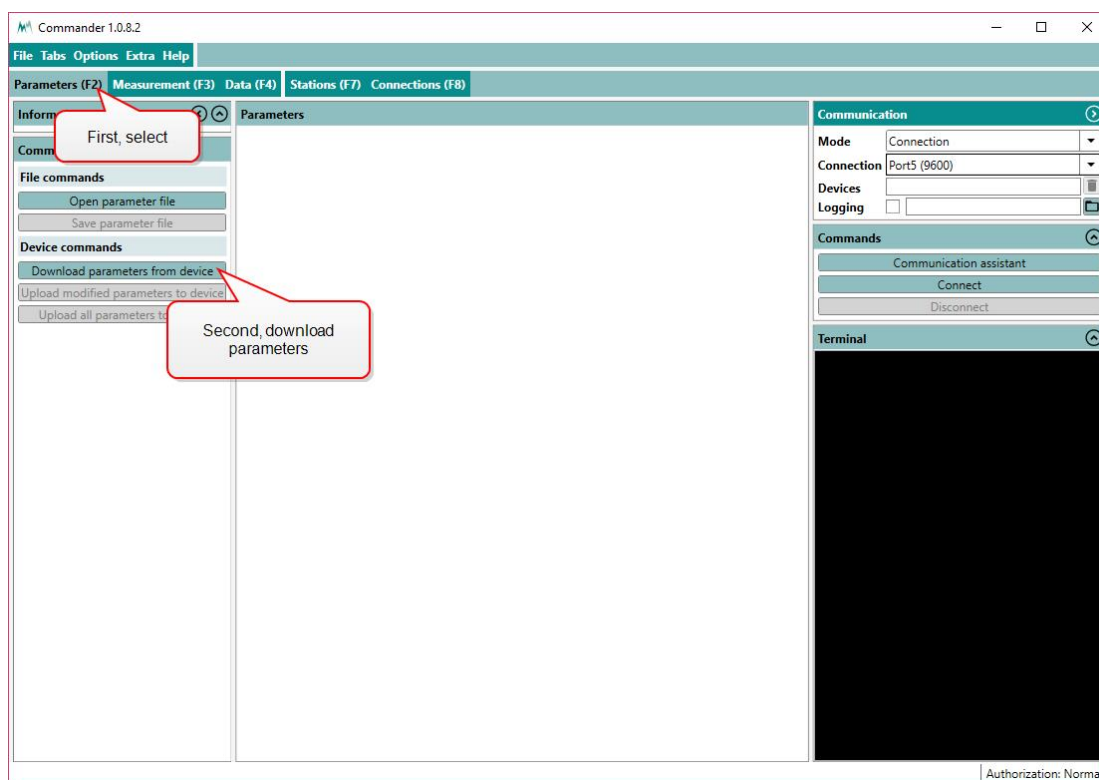

NOTE The first download of the parameter list may take a few minutes. After that the device is known to the PC and consecutive downloads are much faster.

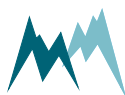

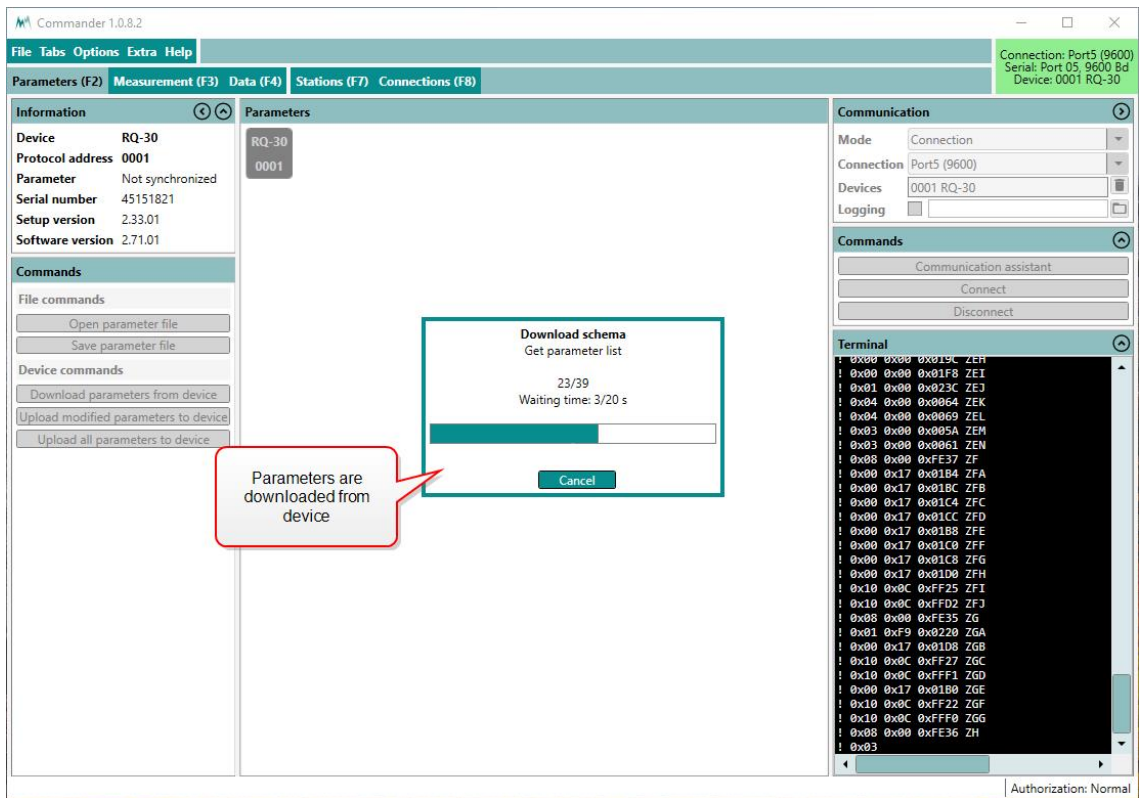

3. Save the parameter file to your PC by clicking **Save parameter file**. This step is recommended to track any configuration changes.

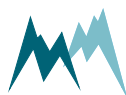
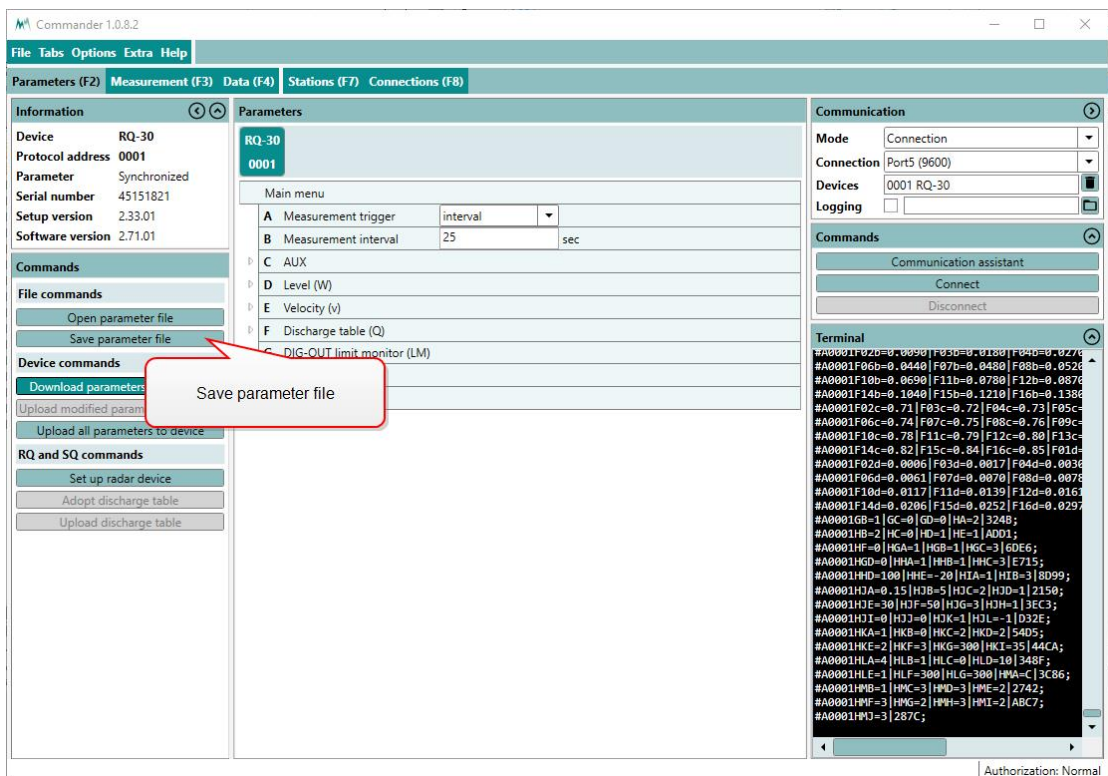

- Adapt the parameters required for your application. Changed values are displayed with a pink background.

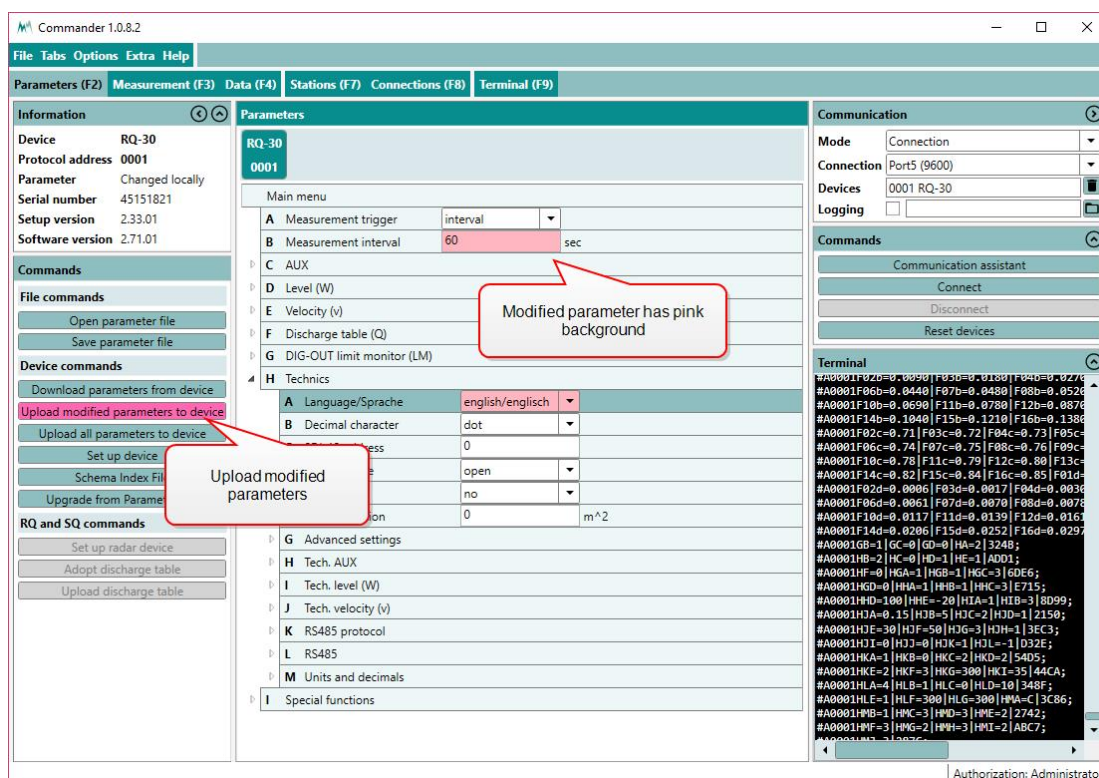

- Send the modifications to the MRL-IE by clicking **Upload modified parameters to device**. Upon successful upload the pink backgrounds disappear again.

12.2 Configuration with a terminal program

The Commander software ships with an integrated terminal program. However, communication with the MRL-IE can be performed with any terminal program.

Follow the steps below to modify the configuration parameters of the MRL-IE:

- Establish a connection between your PC and the MRL-IE.
- In the terminal window enter three question marks (???) in quick succession. The main parameter menu is displayed in response.

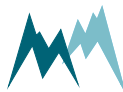

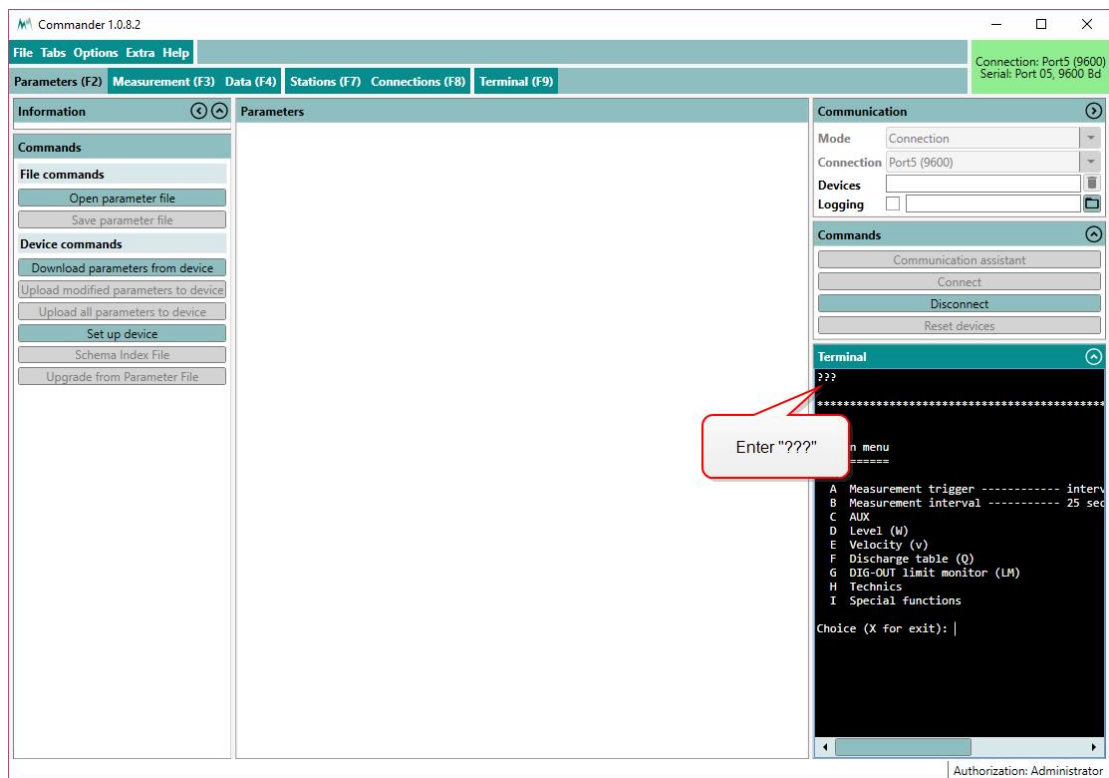

NOTE As an unwanted switching into the menu mode must be avoided the timing of the three question marks ??? is very restrictive and must never be finished with Return/Enter. This is especially important for command line tools, which automatically send a closing "Carriage return". Before and after sending ??? no communication must occur for 1 second.

3. Read or modify the required parameters: The menu items can be selected by entering the letter assigned to each item. Upon selection a submenu is opened or the selected parameter is displayed with its unit. Changes to values are confirmed with **Return/Enter** or discarded with **Esc**. Menus are closed with **X** or **Esc**. After closing the main menu with **X** the device performs an initialization.

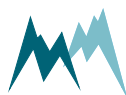

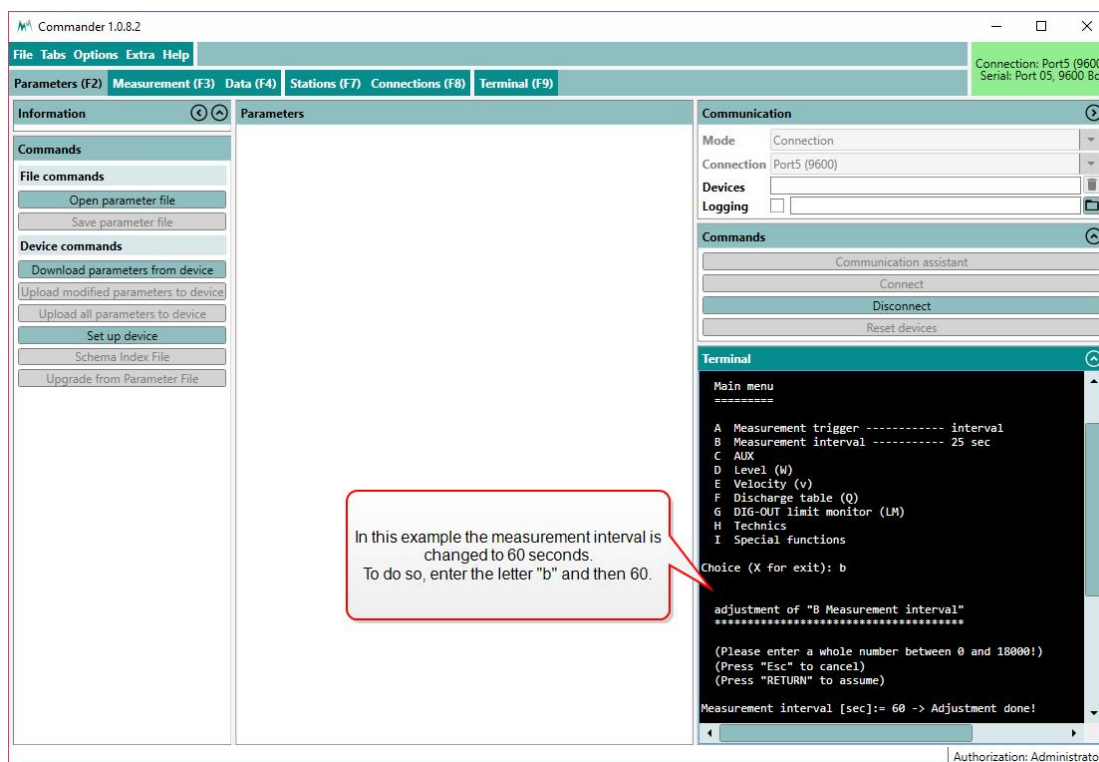

12.3 Configuration errors

12.3.1 Conflict messages

During configuration with the Commander software, the MRL-IE may return conflict messages after one or more parameters have been changed and uploaded to the device. An example is shown in [Figure 8](#).

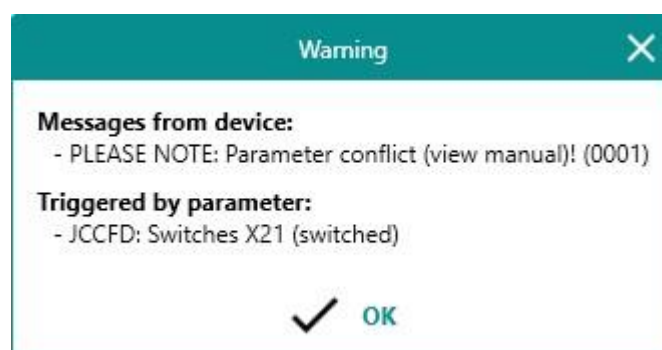

Figure 8 Example of a conflict message

The pop-up window lists the parameters and their indices which have triggered the warning. See [Parameter conflicts](#) for details.



ATTENTION If a conflict occurs, invalid settings are replaced automatically with valid values. Verify the values of the conflicting parameters and adapt them if needed!

12.3.2 Parameter conflicts

A parameter conflict message as listed below is returned if the value of a parameter conflicts with another parameter setting.

Changed parameter	Comment
Measurement channel nr. in Overview (MRL-IEa)	If the value of Measurement channel nr. is higher than Measurements, max. number , Measurement channel nr. is set to Measurements, max. number .
Measurement channel nr. in Digital outputs (MRL-IEa only)	If the value of Measurement channel nr. is higher than Measurements, max. number , Measurement channel nr. is set to Measurements, max. number .
Function in Measurement table	If Function in Measurement table is changed to an option other than <i>actual</i> and Measurement trigger is not <i>interval</i> , Measurement trigger is switched to <i>interval</i> .
Measurement trigger	If Function in Measurement table is not <i>actual</i> and Measurement trigger is changed to an option other than <i>interval</i> , Function is switched to <i>actual</i> .
Measurement output in menu RS485-1 (COM)	If Measurement output is changed to <i>statistic push</i> and Measurement trigger is not <i>interval</i> , Measurement output is switched to <i>measured values push</i> .
Measurement trigger	If Measurement output in menu RS485-1 (COM) is <i>statistic push</i> and Measurement trigger is changed to an option other than <i>interval</i> , Measurement output is switched to <i>measured values push</i> .



Changed parameter	Comment
Measurement output	If Measurement output is changed to <i>statistic push</i> and Measurement trigger is not <i>interval</i> , Measurement output is switched to <i>measured values push</i> .
Measurement trigger	Measurement output is <i>statistic push</i> and Measurement trigger is changed to an option other than <i>interval</i> , Measurement output in menu SBP sensor feedback is switched to <i>measured values push</i> .
Output in menu Digital outputs (MRL-IEa only)	If Output is changed to <i>statistic value</i> and Measurement trigger is not <i>interval</i> , Output is switched to <i>measurement value</i> .

Table 1 Parameter conflict messages

12.3.3 Setup conflicts

A setup conflict message as listed below is returned if a modified setup with conflicting parameters is loaded onto the MRL-IE.

Conflict code	Parameter	Comment
0001	Measurement Interval	If the interval is shorter than the sum of all individual measurement times, it is set to this sum. This internally calculated sum depends on the number and type of measurements, and the settings of Warm-up time, ADC - conv. Rate, ADC filter and others.
0002	Measurement output	If this parameter is set to <i>MODBUS</i> , Measurement output is set to <i>just per command</i> (Modbus can only poll data).

Table 2 Setup conflict messages

12.4 What do I need to configure?

When first setting-up a MRL-IE at a measurement site, the parameters described below may need to be adapted.

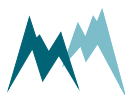

12.4.1 General settings

Language/Sprache

The menu language.

Decimal character

The character used as decimal separator in the values of the settings, in serial data strings and in .csv files.

Measurement Interval

The MRL-IE can perform analog, impulse counter and digital measurements at an interval between 2 s and 12 h.

Interval statistics function

Measurement data can be aggregated according to the **Function** specified in **Measurement table**. The time window for aggregation is set in **Interval statistics function** with a span between 10 s to 12 h.

12.4.2 Measurement table

The data acquired by the MRL-IE are configured in the measurement table. The screenshot below shows an example of a measurement table for an automatic weather station equipped with a combined temperature/humidity sensor, wind speed/direction sensor and a tipping bucket rain gauge.

	Function	Identifier	Unit	Decimals	Scale	Offset			S-TYP	S-NUM	S-MEA	S-ADD
01	Actual	Air temperature	°C	2	100	-40	Adjustment	Test	AIN		An1	
02	Actual	Rel. humidity	%	1	100	0	Adjustment	Test	AIN		An2	
03	Meanval	Wind speed	m/s	2	0,098	0	Adjustment	Test	WIND		Speed	
04	Maximum	Wind speed	m/s	2	0,098	0	Adjustment	Test	WIND		Speed	
05	Meanval	Wind direction	°	1	1,0	0	Adjustment	Test	WIND		Direct.	
06	Actual	Precipitation	mm/h	1	6,0	0	Adjustment	Test	COUNT		Counter 1	
07	Sum	Precip. daily	mm	1	1,0	0	Adjustment	Test	COUNT		Counter 1	SY
08	Actual	Battery voltage	V	1	1,0	0	Adjustment	Test	SYS	0	+Bat V	

Please refer to **Measurement table** for a detailed description of the fields and their options. The configuration of different sensor types is described in Section **Data acquisition examples**.



NOTE

Summed values

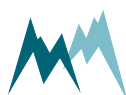



Summing up a measurement value eventually leads to data overflow. The table below shows the maximum of summed variables.

Summarized value	Digits	Max./min. value
Positive integer	7	9 999 999
Negative integer	7	-9 999 999
Positive floating point	7	999 999.9 / 99 999.99 / 9 999.999 / ...
Negative floating point	6	-99 999.9 / -9 999.99 / -999.999 / ...

12.4.3 Analog inputs

The signal type of up to eight analog input terminals can be set. The terminals are then referenced in **S-TYP** of the **Measurement table**. In the sub-menu **Sensor supply** the required supply voltages can be selected.

12.4.4 Analog output settings (MRL-IEa only)

Up to four variables listed in **Measurement table** can be allocated to the analog outputs by specifying their index in **Measurement channel nr.** of **Overview (MRL-IEa)**.

The value corresponding to 4 mA is set in **4 mA value** and the value range corresponding to 4 ... 20 mA is specified in **4-20 mA span**.



EXAMPLE A water level sensor with an SDI-12 output is connected to the MRL-IEa. It measures the level between 0 and 500 cm. This translates to a **4 mA value** of 0 and a **4-20 mA span** of 500 cm.

12.4.5 Digital output settings (MRL-IEa only)

Up to six variables listed in **Measurement table** can be allocated to the digital outputs by specifying their index in **Measurement channel nr.** of **Digital outputs (MRL-IEa only)**. Each output can be configured to either indicate the status of a variable, or return the value of the variable as pulses. The following examples illustrate these two options.

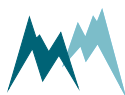

**EXAMPLE**

A water level sensor with an SDI-12 output is connected to the MRL-IEa. If the water level exceeds 3.5 m, it shall switch the digital output **DIG-OUT 3** to its high state to trigger an alarm.

For this task the **Output status** of **Digital outputs (MRL-IEa only)** is set to *Limit monitor*, **Limit type** to *above* and **Limit value** to *3.5*.

**EXAMPLE**

A digital flow meter that measures the discharge of a water irrigation channel is connected to the MRL-IEa. The total discharge shall be displayed by an analog water meter.

For this task the **Output status** of **Digital outputs (MRL-IEa only)** is set to *Impulse output* and **min. impulse width** to, e.g., *100 ms*.

The **min. impulse width** depends on the discharge volume and the response-speed of the water meter.

12.4.6 Totalizer reset options

Precipitation and discharge measurements, among others, require a totalizer function. For example, in water management it is common to report water discharge as daily totals.

To configure a summed variable with a daily reset, the **Function** field in the measurement table has to be set to *sum* and the **Sum, reset time** has to be set to the required time.

12.4.7 Device clock

The clock of the MRL-IE requires regular synchronization. After connection with the Commander software, the time can be set by clicking **Set device time** in the **Parameters (F2)** tab.

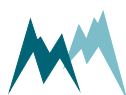

13 Communication

13.1 Communication protocols

The MRL-IE provides the following communication protocols:

- [RS-485](#) (Sommer bus protocol)
- [Modbus](#)
- [SDI-12](#)

13.2 Data output

The MRL-IE includes a RS-485 and a SDI-12 interface for communication and data output. The measurement values returned by one of these ports are arranged in a fixed sequence and are identified by the index in [Measurement table](#). By default the following variables are recorded by the MRL-IE:

13.2.1 Output values

The returned measurement data are indexed according to the entries in the [Measurement table](#). The output format is selected in [Protocol type](#).

Index	Measurement value
1	Variable 01 ^a
2	Variable 02 ^a
3	Variable 03 ^a
...	...
97	Variable 97 ^a
98	Variable 98 ^a
99	Variable 99 ^a

^aAccording to the acquired variables



NOTE The variables listed above can also be configured as auxiliary variables. These are configured in the same way as regular variables but are not stored in the loggers memory. See [Aux measurements, max. number](#) for details.

Table 3 Output values

13.2.2 Exception values

Measurement data may be returned with the following exception values:

Value	Description
99999998	Initial value: No measurement has been performed yet.
99999997	Conversion error: Caused by a technical problem.
99999999	Positive overflow
-99999999	Negative overflow

Table 4 Exception values

13.3 RS-485

13.3.1 What is RS-485?

RS-485 is a serial communication method for computers and devices. It is currently a widely used communication interface in data acquisition and control applications where multiple nodes communicate with each other.¹

13.3.2 What can I do with it?

RS-485 communication is primarily used to trigger measurements and read their results. It also permits to change parameters of the MRL-IE.

¹<https://www.lammertbies.nl/comm/info/RS-485.html>

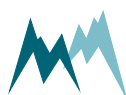

13.3.3 Configuration

The MRL-IE has serial RS-485 communication enabled by default. If the device is integrated into a data network or connected to a stand-alone data acquisition system, the parameters listed in [RS485-1 \(COM\)](#) may need to be adapted.

System key and device number

The system key and device number are used to identify a MRL-IE in a bus system. This is essential if multiple devices (MRL-IE and data loggers) are operated within the same system.

System key

The system key separates different conceptual bus systems. This may be necessary if the remote radio coverage of two measurement systems overlap. In wired setups, the system key should be set to *00*.

Device number

The device number is a unique number that identifies a device in a bus system.



ATTENTION Do not use a device number twice in your bus system! Otherwise communication will fail!

Measurement output

The serial data output can be triggered in the following ways:

ID	Option	Description
1	Just per command	The output is only requested by commands via the RS-485 or SDI-12 interface.
2	Measured values push	Data are returned automatically after each measurement. interval.
4	Statistic push	Statistically aggregated data are returned after each statistics interval.

Operation modes

The selected combination of measurement trigger and output time determines the following operation modes:

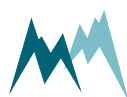

Parameter	Mode		
	Pushing	Polling	Apparent polling
Measurement trigger	internal	TRIG input SDI-12/RS485	TRIG input SDI-12/RS485
OP, measurement output	after measurement	just per command	after measurement

Waking-up a connected data logger

The MRL-IE supports wake-up of a connected data logger that is in standby mode. Generally, this feature is only used in pushing mode and can be set under [Wake-up sequence](#).

Sync sequence

The sync sequence is the string `UU~???` and is sent directly before a command. It is used to synchronize the receiving UART.

Prefix

The prefix is an arbitrary character; the MRL-IE uses a blank. This character is sent prior to any communication. Then the time of the [Prefix holdback](#) is waited and the command is sent afterwards. With this procedure the receiving device has time to wake-up.

Output protocols

For data output via RS-485 different protocols are available, which can be selected under [Protocol type](#).

13.3.4 Data output options

Data are returned in two different formats, selectable in [Protocol type](#):

- [Sommer bus protocol \(SBP\)](#)
- [Standard protocol](#)

13.3.5 Sommer bus protocol (SBP)

The data string of the Sommer protocol has the following format:

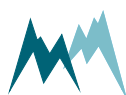



EXAMPLE #M0001G01se01 1461|02 1539|03 25.25|04
0|3883;

A data string contains max. 8 values and is max. 105 characters long.

Header

The header (#M0001G00se) identifies the data by system key, device number and string number.

Parameter	Format	Description
Start character	#	
Identifier	M	M identifies an output string
System key	dd	
Device number	dd	
Command ID	G	G defines an output string with string number
String number	dd	01 Output values dd increments until all values are returned
Command	se	se identifies automatically sent values

Table 5 Header of the Sommer protocol

Measurement value

A measurement value (02 1539|) has a length of 8 digits and is returned together with its index. If the measurement value is a floating point number, one digit is reserved for the decimal character. Values are returned right-aligned, so blanks may occur between index and value.

Parameter	Format	Description
Index	dd	2 numbers
Value	xxxxxxxx	8 character right-aligned
Separator		

Table 6 Values in Sommer protocol

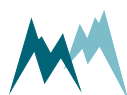

End sequence

The data string is terminated with a CRC-16 in hex format (3883) followed by an end character and <CR><LF>. The CRC-16 is described in [Sommer CRC-16](#).

Parameter	Format	Description
CRC-16	Hhhh	4-digit hex number
End character	;	
Control characters	<CR><LF>	Carriage return and Line feed

Table 7 End sequence of the Sommer protocol

Example Sommer protocol

Output values

The acquired data are returned as in the following example:

EXAMPLE #M0001G 01se01 1461|02 1539|03
 25.25|04 0|3883;

#M0001G01se	Header with system key 00, device number 01 and string number 01
01 1461	Level
02 1539	Distance
03 25.25	Temperature
04 0	Status
3883;	Closing sequence

Table 8 Output values in Sommer protocol



13.3.6 Standard protocol

The data string of the Standard protocol has the following format:

 **EXAMPLE** M_0001 1461 1359 25.38 0

Header

The header (M_0001) identifies the data by system key and device number.

Parameter	Format	Description
Identifier	X_	M_ Measurement values
System key	Dd	
Device number	Dd	

Table 9 Header of the Standard protocol

Measurement values

Measurement values are returned in sequence and are separated by a blank. A measurement value has a length of 8 digits. If the measurement value is a decimal number, one digit is reserved for the decimal character. Values are returned right-aligned, so additional blanks may be returned between values.

Parameter	Format	Description
Separator	[blank]	blank
Value	xxxxxxxx	8 character right-aligned

Table 10 Values in Standard protocol



NOTE With the standard protocol the data strings can be very long. In contrast, the strings of the Sommer protocol are max. 105 characters long.

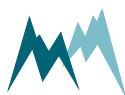

End sequence

The data string is terminated with <CR><LF>.

Example Standard protocol

Output values

The acquired data are returned as in the following example:



 EXAMPLE M_0001 1461 1359 25.38 0	
M_0001	Header with identifier for measurement values
1461	Level
1359	Distance
25.38	Temperature
0	Status

Table 11 Output values in Standard protocol

13.3.7 Sommer old protocol

The data string of the Sommer old protocol has the following format:

 EXAMPLE #M0001G00se00 -17.4 01 0.535 02 0.000 03 -1.89 04 0.0 05 0 B11D;

This protocol is identical with the Sommer protocol except that the index of the measurement values starts at 0 instead of 1.

This protocol has been implemented for compatibility reasons: When a Sommer device with firmware < 2.0 is updated to version 2.x the protocol is automatically set to Sommer old. Thus, the setup of a connected data logger does not have to be adjusted.

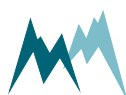

13.3.8 Serial commands

Command structure

The structure of serial commands and answers is described in the following table:

Parameter	Format	Description
Start character	#	
Identifier	X	<p>W Write: MRL-IE returns a confirmation on receipt. This command type demands a closing sequence with a valid CRC-16.</p> <p>S Silent: MRL-IE does not acknowledge the receipt of the command. This command type demands no closing sequence and therefore no CRC-16.</p> <p>R Read: MRL-IE returns the requested measurement value or parameter. This command type demands a closing sequence with a valid CRC-16.</p> <p>T Temporary: Write a volatile, temporary setting and receive a confirmation.</p> <p>A Answer: Answer of device to read or write command.</p>
System key	dd	
Device number	dd	
Command	xxx	See table in section Commands .
Separator		
CRC-16	hhhh	4-digit hex number
End character	;	

Table 12 Structure of Sommer bus commands and answers

Commands

The following commands can be used with the MRL-IE:

Command	Description
\$mt	Trigger a measurement
\$pt	Return measurement values
XX	Read a parameter with identifier XX
XX=xxxx	Write a parameter with identifier XX and the value xxx

Table 13 List of Sommer bus commands

Trigger a measurement

The command \$mt triggers a complete measurement sequence as in the following example:

 **EXAMPLE** #W0001\$mt|BE85; Answer: #A0001ok\$mt|4FA9;

Read a parameter value

Read measurement interval (in the example below the menu item B):

 **EXAMPLE** #R0001B|228E; Answer: #A0001B=300|F8B3;

Request a complete data string

The command \$pt requests a data string as in the following example:

 **EXAMPLE**

Option 1
#W0001\$pt|7D19; Answer: #A0001ok\$pt|8C35;

Option 2
#S0001\$pt| Answer: none

The measurement data string is returned as soon as the MRL-IE has processed the command.

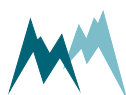



NOTE If **Measurement output** is set to *Measured values push*, the data strings are returned automatically after the measurements have been completed.

Request a single measurement value

The reading command `R` together with the index of the requested measurement returns a single measurement value. In the following example the measurement value with index 01 (in this example a water level) is requested:



EXAMPLE

```
#R0001_010cv|EA62;
```

```
Answer: #A0001ok_010cv1461 |07EB;
```

13.3.9 Sommer CRC-16

The CRC-16 (cyclic redundancy check) used in data transmission of Sommer devices is based on the ZMODEM protocol. When data are exchanged between two devices the receiving device calculates the CRC-value. This value is compared to the CRC value sent by the other device to check if the data were transmitted correctly. Please refer to technical literature or contact Sommer for calculation of CRC-16 values.

You can [here](#) calculate the CRC of a command online .

If you need to compute CRCs automatically, you can implement the following procedure in your data logger or controller software.

The CRC-16 is calculated character by character. The start value for the initial CRC-16 calculation is always 0.

The following procedure returns the CRC-16 of a single character:

```
byte1 = CRC-16 right shift by 8 bits           upper byte disappears  
uint1 = c                                     new character, upper byte = 0  
uint2 = CRC-16 left shift by 8 bits           lower byte = 0  
uint3 = crc16tab[byte1]                       Table value from the CRC-16 table  
Crc16 = uint3 (excl. or) uint2 (excl. or) uint1
```



Computation CRC-16 in C/C++

```
1 | crc16 = crc16tab[(unsigned char)(crc16>>8)] ^ (crc16<<8) ^ (unsigned int)(c);
```

The `crc16tab` array is listed in [CRC-16 array](#).



EXAMPLE

Command to request measurement data `#W0001$pt|7D19;`

The first character is `#`, the last `|`. The CRC-16 of the command is `7D19` and its end character is `;`.

The CRC-16 is calculated sequentially with the start value `0` for the initial CRC-16 calculation:

Position	String	CRC-16
Start		0000
0	#	0023
1	#W	2357
2	#W0	4331
3	#W00	4997
4	#W000	4EDD
5	#W0001	743B
6	#W0001\$	0537
7	#W0001\$p	67D5
8	#W0001\$pt	C935
9	#W0001\$pt	7D19

13.4 SDI-12

13.4.1 What is SDI-12?

SDI-12 (Serial Data Interface at 1200 Baud) is a serial data communication standard for interfacing multiple sensors with a single data recorder. For a detailed description on SDI-12 communication please refer to www.sdi-12.org.

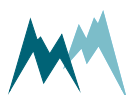

13.4.2 What can I do with it?

The MRL-IE listens to standard SDI-12 commands as listed in the SDI-12 specifications of version 1.3, e.g., to trigger a measurement or retrieve measurement results. Additionally, a set of extended SDI-12 commands is implemented in all SOMMER sensors for instrument configuration.

The MRL-IE can be used as an SDI-12 master, sending commands to devices connected to the SDI-12-2 port. See [Data acquisition examples](#) for more details and examples.

13.4.3 Configuration

The MRL-IE has SDI-12 communication enabled by default. When setting up a SDI-12 network take the following considerations into account:

- Each device in the SDI-12 network must have a unique address, e.g. data logger address *0*, MRL-IE address *1*.
- If the MRL-IE operates in polling mode ([Measurement trigger](#) set to *SDI-12/RS-485*), measurements are triggered by *M!* commands and data are retrieved by *D!* commands.
- If the MRL-IE operates in pushing mode ([Measurement trigger](#) set to *interval*), data are retrieved by the *R!* commands.
- When multiple sensors are connected to the same network, data acquisition should be done in sequence, i.e., data should have been received from the first sensor before triggering the measurement of the second sensor.
- Most data loggers control the timing of messages (marking and spacing) automatically. If this is not the case, please refer to www.sdi-12.org.

13.4.4 Data structure

The answer from the SDI-12 device is a string containing the sensor address, the requested data and a terminating carriage return/line feed.

In a string containing measurement data, the measurements are returned in the same order as listed by the index in [Data output](#).



EXAMPLE

```
0+2591+706+25.53+62<CR><LF>
```

Value	Content
0	Sensor address
2591	Measurement with index 01

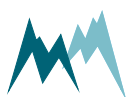



Value	Content
706	Measurement with index 02
25.53	Measurement with index 03
62	Measurement with index 04

If a device returns more than 9 measurement values, or if the values are returned in groups (see also [Request results](#)) the measurement index increments in the next group.

**EXAMPLE**

0D0! Answer: 0+2591+706+25.53+62<CR><LF>

0D0! Answer: 0+56.2+125+12.32<CR><LF>

Value	Content
0	Sensor address
2591	Measurement with index 01
706	Measurement with index 02
25.53	Measurement with index 03
62	Measurement with index 04
0	Sensor address
56.2	Measurement with index 05
125	Measurement with index 06
12.32	Measurement with index 07

13.4.5 SDI-12 commands

The following tasks can be performed with standard and extended SDI-12 commands.

Extended SDI-12 commands are non-standard commands implemented by SOMMER to enable device configuration via SDI-12.



NOTE After any changes, the settings have to be adopted with the command `aXW_ts|!`, with `a` the sensor address.

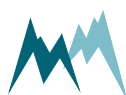

Command structure

A standard SDI-12 command starts with the sensor address and ends with an exclamation mark, e.g., 0M! to trigger a measurement.

Configuration commands contain additional information; see the sections below for details.

Identify device

The identification of a SDI-12 device is requested with the command aI!, with a the sensor address.

 **EXAMPLE**

0I! Answer 013Sommer USH 140r90 USH-9 <CR><LF>

The answer contains the following information:

0	SDI-12 address
1	SDI-12 version prior to the point
3	SDI-12 version after the point
Sommer	Description of the company (6 characters and 2 blanks)
USH	Description of the firmware (5 characters and 2 blanks)
140r90	Firmware version (6 characters and 2 blanks)
MRL-IE	Device designation (max. 13 characters)

Acquire measurements

To acquire a measurement from a sensor, two individual SDI-12 commands – trigger a measurement and request measurement values – need to be sent.

 **EXAMPLE**

0M! Answer: 00084<CR><LF> and 0<CR><LF> after 8 seconds

0D0! Answer: 0+2591+706+25.53+0<CR><LF>

The first values in the response to the aDn! command is the sensor address.



Trigger measurement

The command `aM!` with sensor address `a` triggers a measurement as in the example below.

The response states the measurement duration and the number of measurement values (see example below). After completion of the measurement, the device will return an additional `a<CR><LF>`, with `a` the sensor address.



EXAMPLE

`0M!` Answer: `00084<CR><LF>` and `0<CR><LF>` after 8 seconds

The answer contains the following information:

<code>0</code>	SDI-12 address
<code>008</code>	Duration of the measurement in seconds
<code>4</code>	Number of measurement values

Request results

After each measurement, results are requested with the command `aDn!`, with `a` the sensor address and `n` the index of the returned data string.



EXAMPLE `0D0!` Answer: `0+2591+706+25.53+0<CR><LF>`

The leading `0` of the response is the sensor address.

Generally, the command `aD0!` is sufficient to request up to 9 measurement values. If more than 9 values need to be read, or if the values are returned in groups, the commands `aD1!`, `aD2!`, ... may need to be issued after `aD0!`. For example, if a measurement returns 8 values in two groups of 4, the commands `aD0!` and `aD1!` need to be issued to receive all values.

Acquire continuous measurements

If the SDI-12 device is operating in continuous measurement mode (not polled by SDI-12), the command `aR0!` will request and return the current reading of the sensor. The values within the data string follow the order listed in the measurement table. The first values in the response to the `aRn!` command is the sensor address.



**EXAMPLE**

0R0! Answer: 0+2591+706+25.53+0<CR><LF>

If more than 9 values need to be read, or if the values are returned in groups, the commands aR1!, aR2!,... may need to be issued after aR0!. For example, if a measurement returns 8 values in two groups of 4, the commands aR0! and aR1! need to be issued to receive all values.

Configure parameter

The configuration parameters of a SOMMER sensor are read with the command aXRpp! and written with the command aXWpp=vvv!, with a the sensor address, pp the parameter identifier and vvv the value of the parameter.

Read and write a parameter**EXAMPLE**

Reading of measurement interval (in this example menu item B)

0XRB|! Answer: 0B=300|<CR><LF>

Setting of measurement interval to 60 s (in this example menu item B)

0XWB=60|! Answer: 0B=60|<CR><LF>

Read and write a selector-parameter

Changing the measurement trigger (in the following example menu item A) from *interval* to *SDI-12/RS485*:

**EXAMPLE**

0XRA|! Answer: 0A=1|<CR><LF>

0XWA=3|! Answer: 0A=3|<CR><LF>

Read and write a parameters of a table

Some SOMMER sensors are equipped with multiple transducers and their settings are listed in a table (see example below). A value within such a table is addressed by its row-index (01, 02 ...) and column-

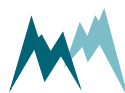

index (A, B ...). A corresponding SDI-command has the following format:



EXAMPLE

In this example of a snow scale the value in row 01 and column B of the parameter D-D-E is changed to -1.4.

0XWDDE01B=-1.4|!

Answer: 0DDE01b=-1.4|<CR><LF>

	Identifier	offset zero kg	gain	zero default kg	gain default
01	Load Cell 1	-1.4	0,997787	0,000	0,997787
02	Load Cell 2	0,000	0,997787	0,000	0,997787
03	Load Cell 3	0,000	0,997787	0,000	0,997787
04	Load Cell 4	0,000	0,997787	0,000	0,997787

Adopt settings

Some settings need to be adopted with the command `aXW_ts|!`, with `a` the sensor address. It is recommended to issue `aXW_ts|!` after each configuration change.

13.5 Modbus

13.5.1 What is Modbus?

Modbus is a serial communication protocol used for transmitting information over serial lines between electronic devices. The device requesting the information is called the Modbus Master and the devices supplying information are Modbus Slaves. In a standard Modbus network, there is one Master and up to 247 Slaves, each with a unique Slave Address from 1 to 247. The Master can also write information to Slaves.

Modbus has become a standard communication protocol in industry, and is now the most commonly available means of connecting industrial electronic devices. It is often used to connect a supervisory computer with a remote terminal unit (RTU) in supervisory control and data acquisition (SCADA) systems. Versions of the Modbus protocol exist for serial lines (Modbus RTU and Modbus ASCII) and for Ethernet (Modbus TCP).¹

¹<http://www.simplymodbus.ca/FAQ.htm>

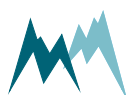

13.5.2 What can I do with it?

Modbus-communication with MRL-IE allows reading of measurement values and device information by a Modbus master. Additionally, the basic RS-485 port settings can be written to the MRL-IE.

13.5.3 Wiring

For Modbus communication the MRL-IE is wired according to the table below.

Modbus	Connector MAIN	Connection wire	Description
Common	Pin 1	White	GND
D1 - B/B	Pin 4	Yellow	RS-485 A
D0 - A/A	Pin 5	Grey	RS-485 B

Table 14 Modbus wiring



NOTE

Please note that different signal notations are in use for RS-485 connections:

TX+/RX+ or D+ or D1 as alternative for B

TX-/RX- or D- or D0 as alternative for A



NOTE If the MRL-IE is operated with multiple Modbus devices within the same network, termination resistors may be required. Please contact Sommer Messtechnik for details.

13.5.4 Modbus configuration

Follow the instructions below to change the communication of a Sommer-device (in this example a RG-30) to Modbus:

1. Connect the USB to RS-485 converter to the data cable of the Sommer-device and a USB port on your PC.
2. Connect the sensor to a power supply with the specified rating.
3. Start the Commander software on your PC.
4. Establish a connection to the Sommer-device.

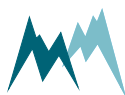

- Download the sensor's parameters in the **Parameters (F2)** tab and save the parameter list on your PC.

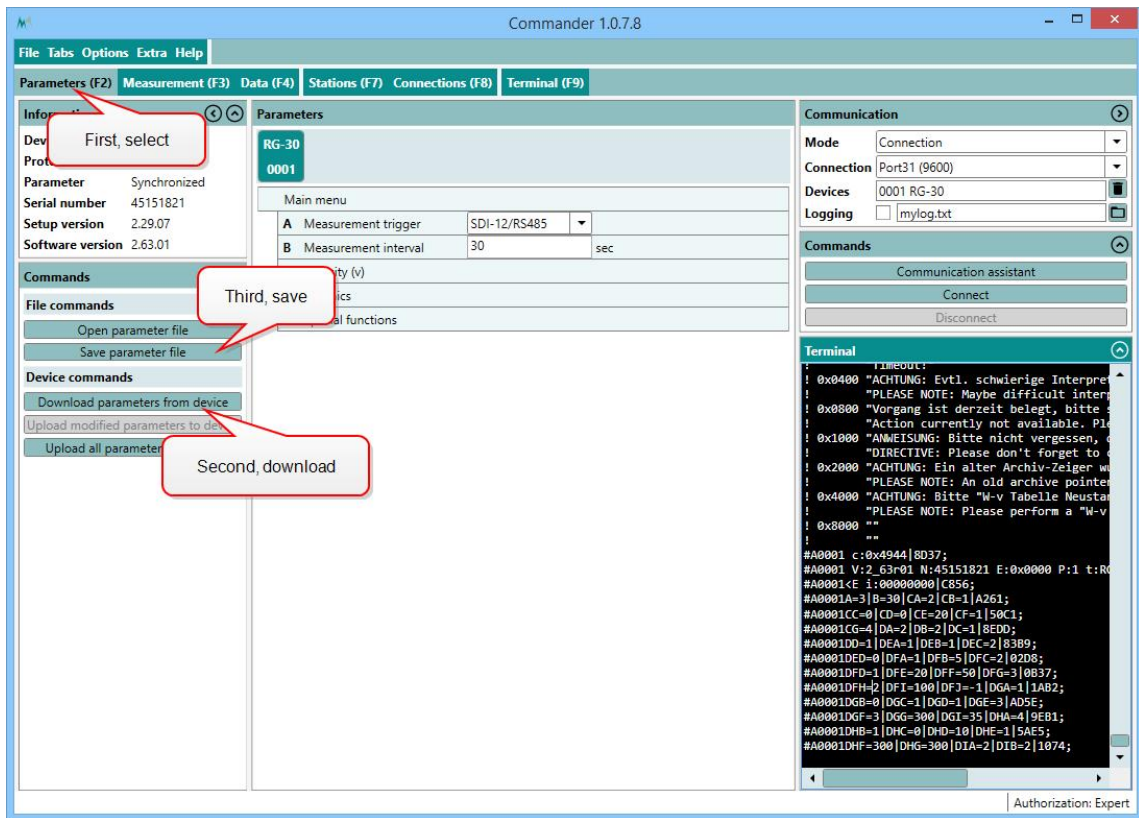

- In the parameter list navigate to Technics and open the menus **RS-485 protocol** and **RS485** and take a screenshot of the associated parameters. This and the previous step are helpful if you need to switch back to the standard communication mode at a later time.

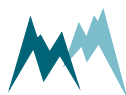

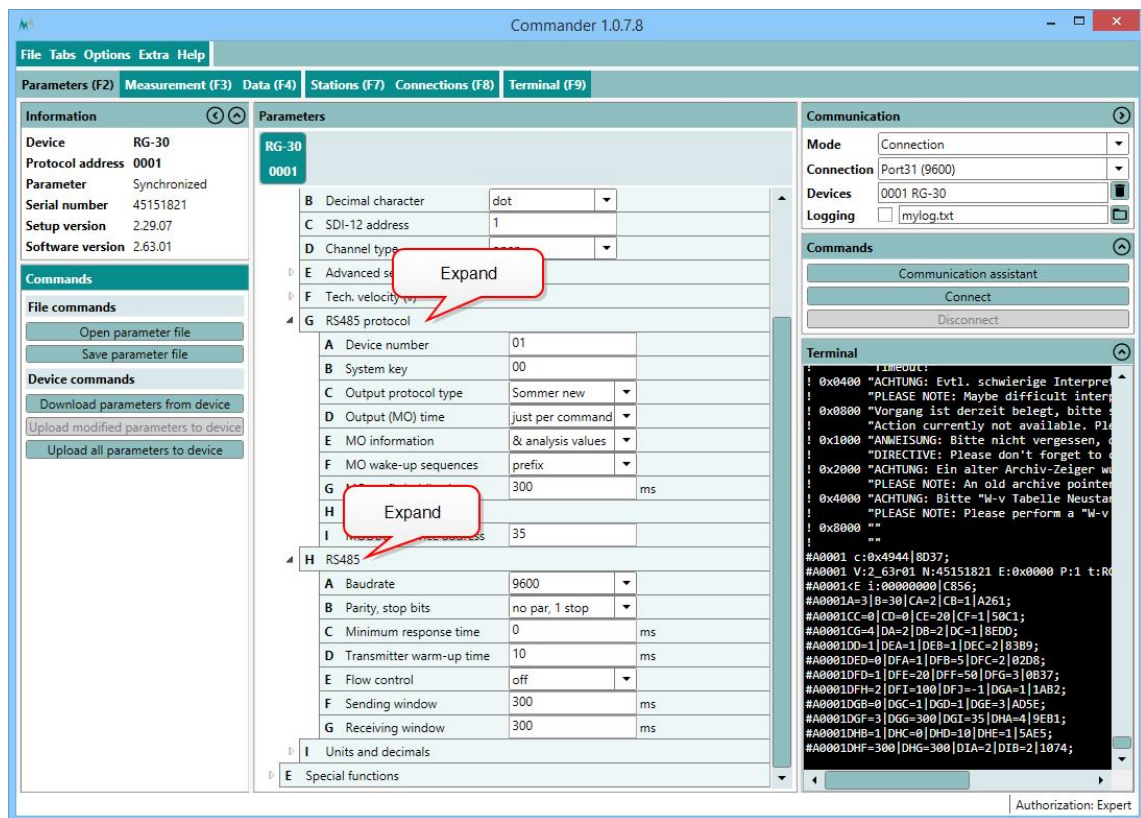

7. Set **Measurement trigger** to one of the following options:
 - A. *Interval*, if measurements are triggered internally by the device.
 - B. *SDI-12/RS-485*, if measurements are triggered by SDI-12.
 - C. *TRIG input*, if measurements are triggered by a trigger input.
 - D. *all allowed*, if measurements are triggered by one of the previous options.



NOTE Modbus cannot trigger measurements! Make sure to use the trigger option suitable for your application!

8. Verify that the connection to the Sommer-device is active and click into the Terminal window. Type `???` to enter the sensor-menu.

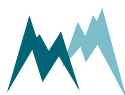

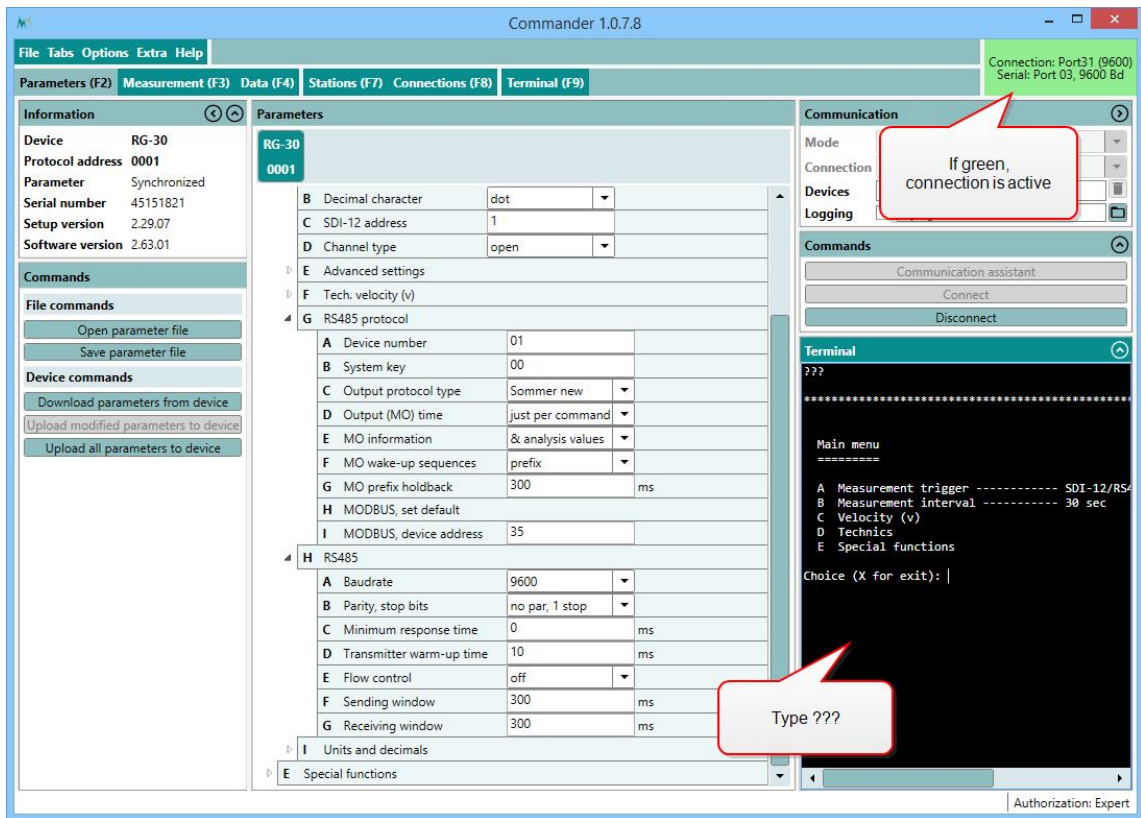

9. Navigate to *RS485 protocol* and select *MODBUS, set default...* Please note, that the index-letters might be different for your Sommer-device!

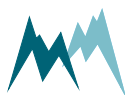

```

Terminal

Main menu
=====

A Measurement trigger ----- SDI-12/RS485
B Measurement interval ----- 30 sec
C Velocity (v)
D Technics
E Special functions

Choice (X for exit): d

Technics
=====

A Language/Sprache ----- english/englisch
B Decimal character ----- dot
C SDI-12 address ----- 1
D Channel type ----- open
E Advanced settings
F Tech. velocity (v)
G RS485 protocol
H RS485
I Units and decimals

Choice (X for exit): g

RS485 protocol
=====

A Device number
B System key --
C Output protocol
D Output (MO) t
E MO information
F MO wake-up se
G MO prefix holdback ----- 100 ms
H MODBUS, set default...
I MODBUS, device address ----- 35

Choice (X for exit): |

```

Enter the letter of 'MODBUS, set default ...'

10. Acknowledge the safety-note.

```

Start up testmode: 0x09

MODBUS, set default
AAAAAAAAAAAAAAAAAAAA

PLEASE NOTE: This process changes to 19200 baud, even parity, ...
DIRECTIVE: Please don't forget to change the serial counterpart too!

Are you sure?

(Press "RETURN" to assume)
(Press "Esc" to cancel)

```

Press Enter

11. After completion the following message will be displayed:

```

=> Testmode finished!
=> DIRECTIVE: Please don't forget to change the serial counterpart too!

```

12. Enter X until you get back to the main menu. The Sommer-device is now restarted and available for Modbus-communication. As the connection-parameters have been changed to Modbus, the connection to the sensor is lost. Press Disconnect for completion.

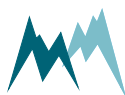

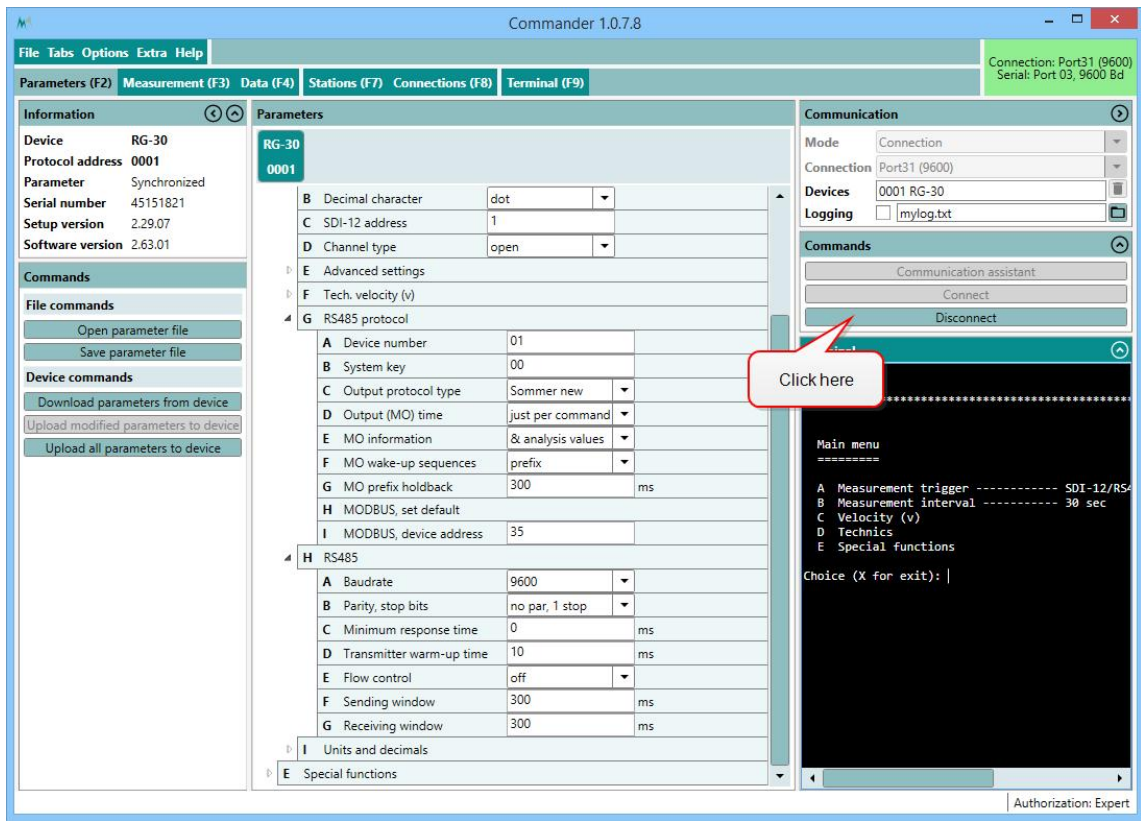

NOTE

By switching communication to Modbus with **MODBUS, set default** the following parameters are changed:

Parameter	Modbus setting
OP, measurement output	just per command
Output protocol (OP)	Modbus
MODBUS, device address	35
Sleep mode	Modbus, slow
Parity, stop bits	even par, 1 stop
Baud rate	19200
Flow control	off
Transmitter warm-up time	10 ms
Minimum response time	30 ms



TIP To change a parameter in the **Technics** menu you need to change your Commander-authorization to Expert. See [Change authorization](#) for instructions.

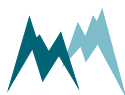

13.5.5 Modbus commands and registers

Read input registers

Input registers contain measurement values. The content of these registers is updated after each measurement.

	Index	Register address	Variable	Unit / value	Bytes	Format
Test value		0	Hardcoded test value	2.7519...	4	float
Main values	01	2	Variable 01 ^a	a	4	float
	02	4	Variable 02 ^a	a		
	03	6	Variable 03 ^a	a		
 ^a	... ^a		
	78	156	Variable 78 ^a	a		
	79	158	Variable 79 ^a	a		
	80	160	Variable 80 ^a	a		
Device info	-	65533	Device type and configuration	3701	2	unsigned int
	-	65534	Software version	XYYZZ	2	
	-	65535	Modbus version	10100	2	

^aAccording to entries in [Measurement table](#)

Table 15 Input registers



NOTE The 4-byte float values have the format *ABCD*, big-endian (*A* is the most significant byte).

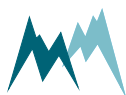

Read and write holding registers

Holding registers are mainly used to configure the Modbus adapter communication. Configuration settings are read with function 03 (read holding registers) and written with function 06 (write single registers).



NOTE Restart the Modbus adapter after changing the configuration!

	Register address	Variable	Range	Bytes	Format
Config values	0	Modbus default ¹	0 - 1...read 1...write	2	unsigned int
	1	Modbus device address	1 to 247		
	2	RS-485 baud rate	1...1200 baud 2...2400 baud 3...4800 baud 4...9600 baud 5...19200 baud 6...38400 baud 7...57600 baud 8...115200 baud		
	3	RS-485 parity/ stop bits	1...no parity, 1 stop bit 2...no parity, 2 stop bits 3...even parity, 1 stop bit 4...odd parity, 1 stop bit		

Function 06 and Function 03 to read and write configuration values

Table 16 Holding registers

Report slave ID

The Modbus function 17 (report slave ID, read only) can be used to read basic information of the MRL-IE. The following example shows the response of function 17 of a RG-30 sensor, which is received in hex-format:

¹Writing "1" sets the Modbus default settings.

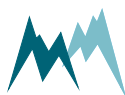



EXAMPLE 23 11 26 53 FF 27 74 20 53 6F 6D 6D 65 72 20
 20 52 47 2D 33 30 20 20 20 32 5F 37 31 72 30 31 20 34
 35 31 35 31 38 32 31 00 BB D4

			Example	
	Content	Length (Bytes)	HEX-value	Decimal, ASCII
PDU ¹ response	Slave address	1	23	35
	Function code	1	11	17
	Number of bytes (excl. slave-address, function code, NUL and CRC)	1	26	38
	Slave ID	1	53	"S"
	Run status (0=inactive; FF=active)	1	FF	255
	Modbus implementation version	2	27 74	10100
	Separator	1	20	" "
	Vendor string	7	53 6F 6D 6D 65 72 20	"Sommer "
	Separator	1	20	" "
	Device configuration	7	52 47 2D 33 30 20 20	"RG-30 "
	Separator	1	20	" "
	Software version	7	32 5F 37 31 72 30 31	2_71r01
	Separator	1	20	" "
	Serial number	8	34 35 31 35 31 38 32 31	45151821
	NUL	1	00	
	CRC	2	BB D4	

Function 17 to report slave ID

¹Protocol Data Unit

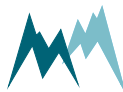

13.5.6 Reactivate Sommer protocol

Follow the instructions below to change the data output back to Sommer-protocol:

1. Open the **Connections (F8)** tab and click **New connection**.

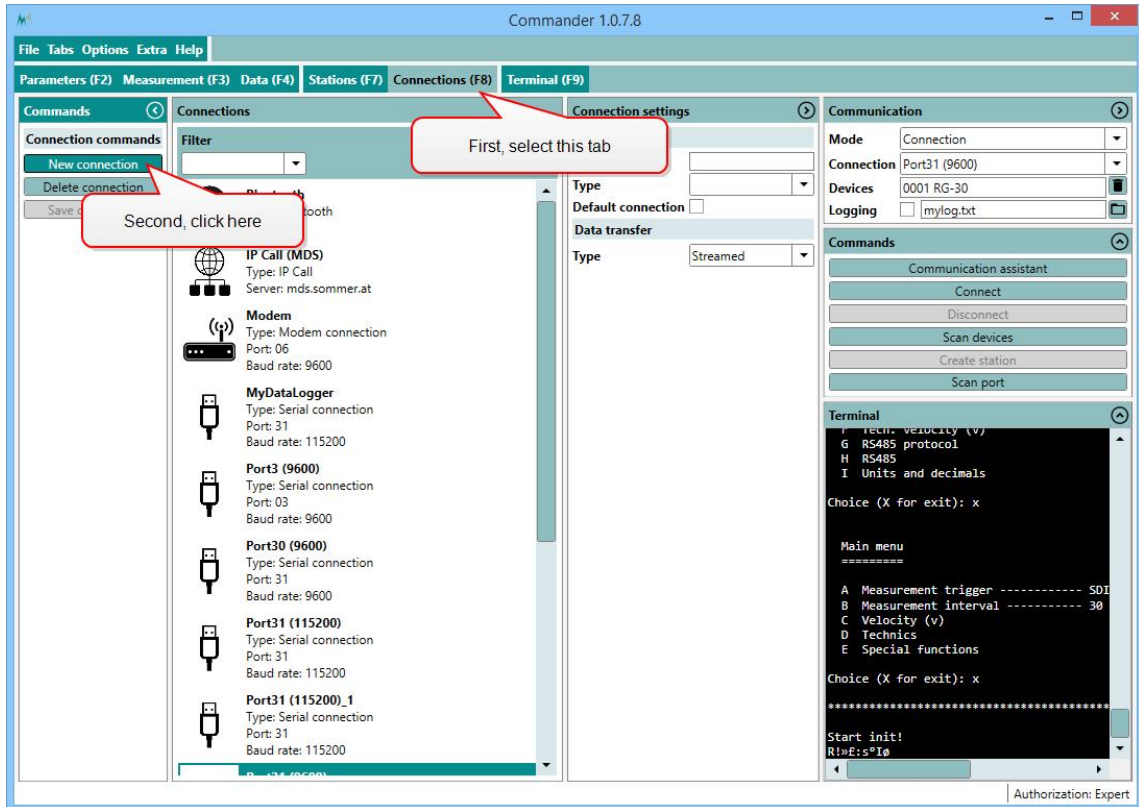

2. Enter the **Name** of the new connection. We recommend to use a meaningful name for later recognition, e.g. Modbus31 (19200) to indicate port 31 and Baud-rate 19200. Select the **Type** **Serial connection** and choose the **Port** your sensor is connected to, set the **Baud-rate** to **19200** and the **Parity/stop bits** to **Even par., 1 stop bit**.

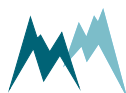

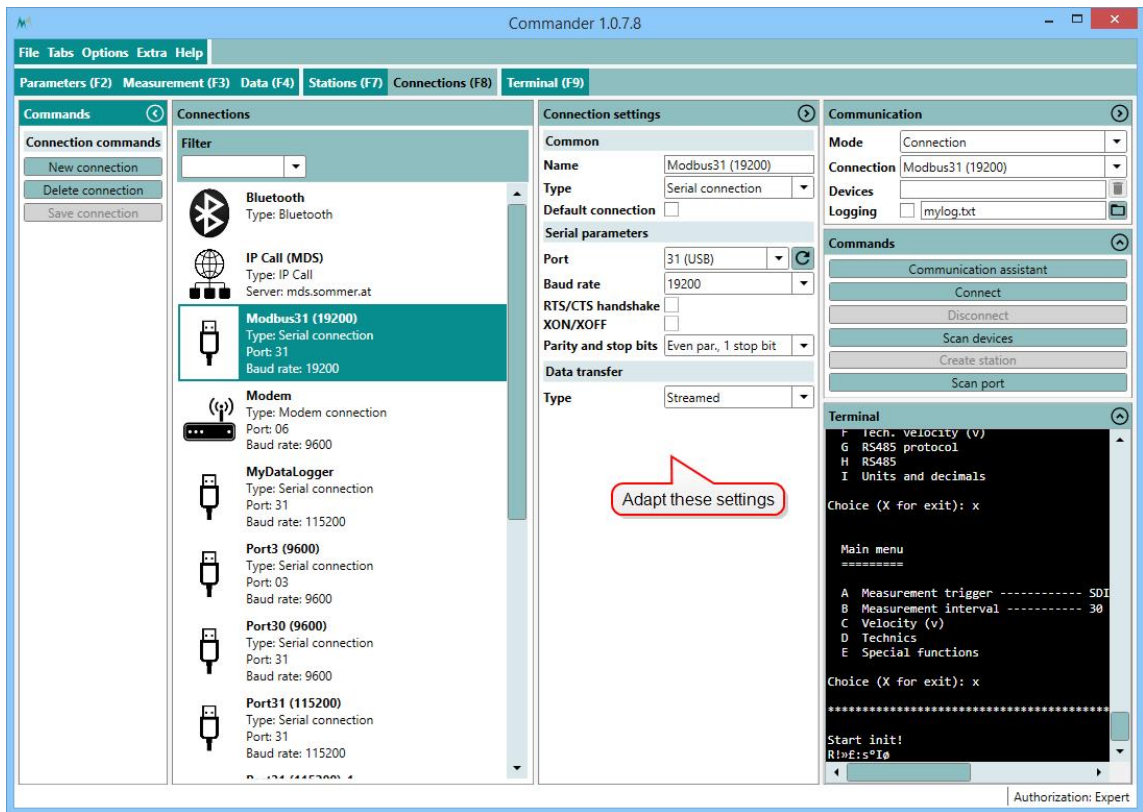

3. Click **Save connection**.
4. In the **Communication** window select **Mode Connection** and choose the **Connection** you have created. Then click **Connect**.

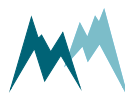

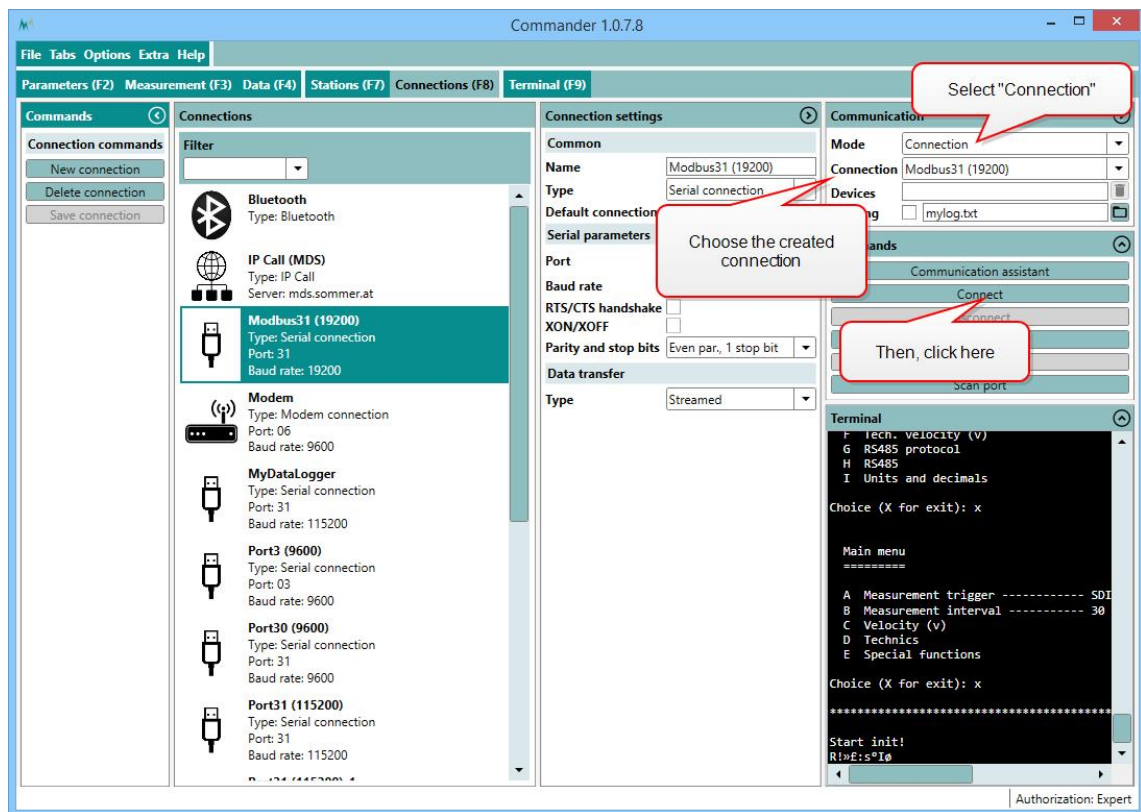

5. Download the parameters and save the parameter file as described in [Modbus configuration](#).



TIP Save the parameter file for future use and to document configuration changes!

6. Now, two options are available to revert communication back to the Sommer-protocol:
 - A. If a parameter file is available that has the Sommer-protocol enabled, the file can be loaded by clicking [Open parameter file](#), selecting the respective file and uploading the parameters to the device by clicking [Upload all parameters to device](#).

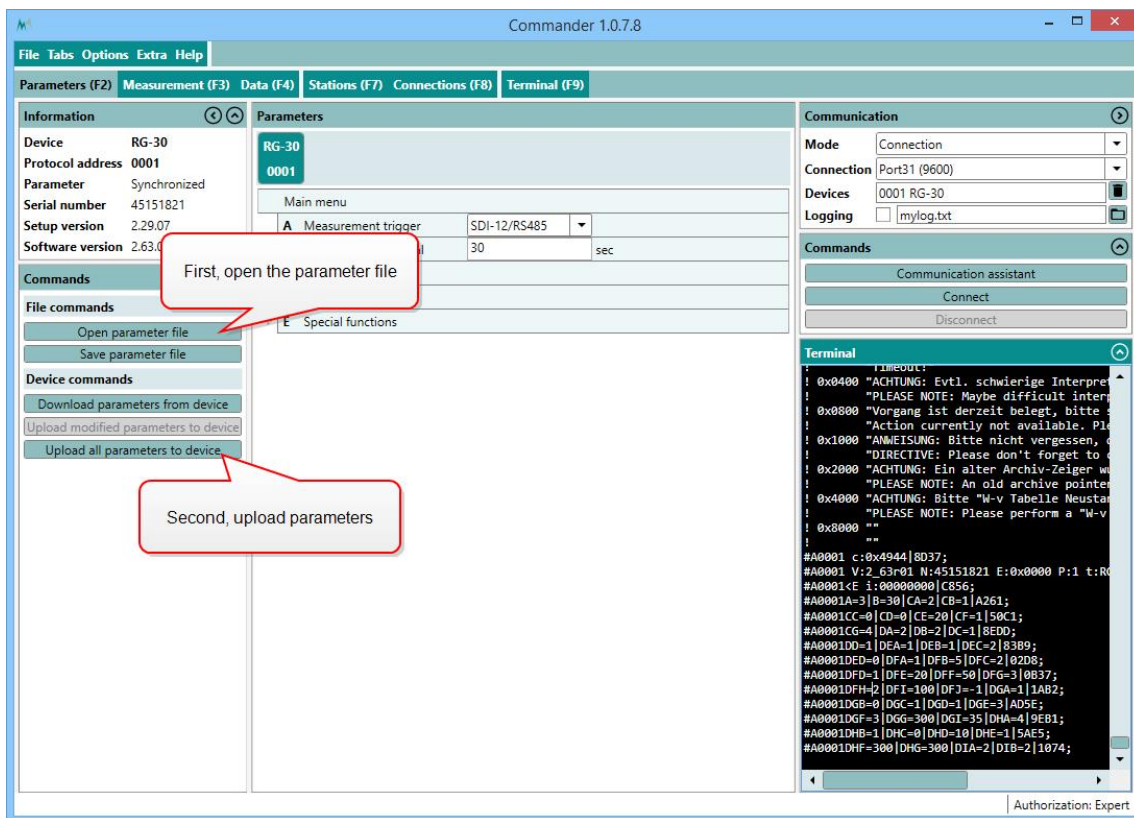

B. If no parameter file is available, the device has to be reset to its default configuration:

1. Click into the **Terminal** window and type ??? to enter the sensor-menu.

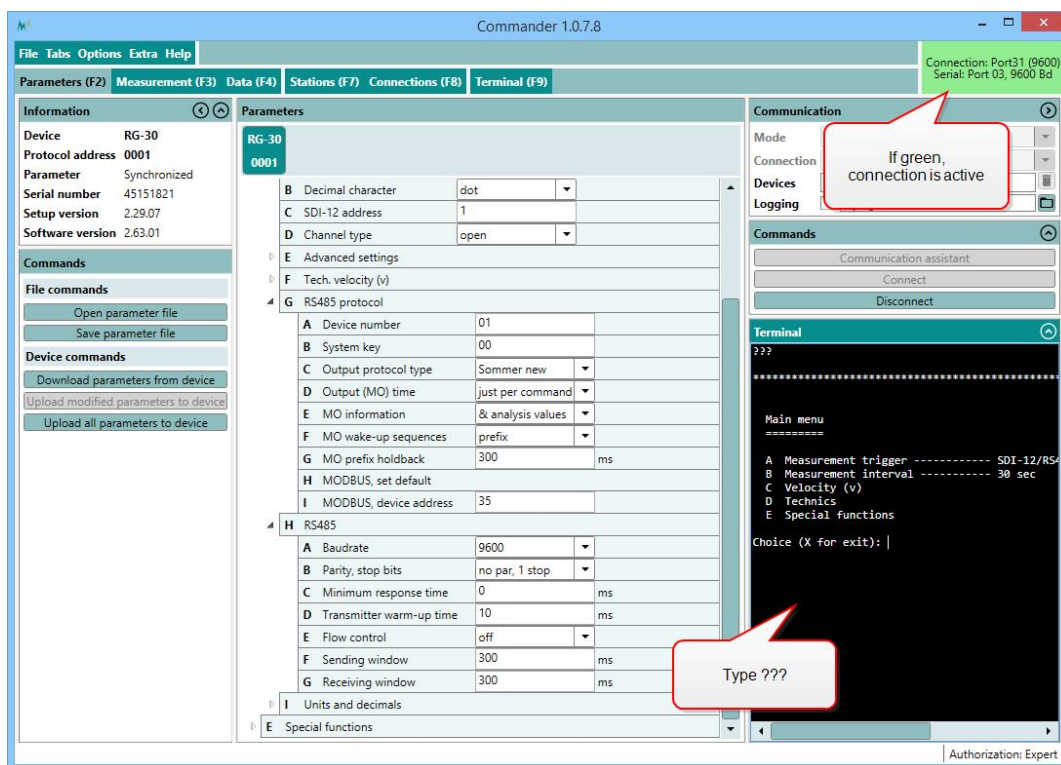

2. Navigate to **Special functions** and select **Set factory default...**

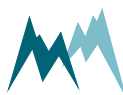

- Acknowledge the safety-note.

```

Start up testmode: 0x07

Set factory default
^^^^^^^^^^^^^^^^^^^^

PLEASE NOTE: Please save all parameters before!
PLEASE NOTE: All user settings will be lost!
Are you sure?

(Press "RETURN" to assume)
(Press "Esc" to cancel)

=> Testmode finished!

```

- Enter `X` until you get back to the main menu. The Sommer-sensor is now restarted and available in its initial configuration. As the connection-parameters have been changed to the default settings, the connection to the sensor is lost. Press **Disconnect** for completion.
- Establish the original connection to the Sommer-sensor as described in [Modbus configuration](#).
- Download the sensor's parameters in the **Parameters (F2)** tab, adapt the required parameters, or upload your originally saved parameter file to the MRL-IE.

13.5.7 PLC integration

The MRL-IE can be integrated into a PLC system as a slave device. It supports the PROFIBUS, PROFINET, EtherCAT and CANopen protocols. This requires an additional serial converter, e.g. Anybus Communicator.

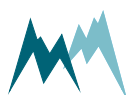

14 Data acquisition examples

As listed in [What can I do with it?](#) the MRL-IE accepts a wide range of sensor inputs. In this section the data acquisition of the most common sensor types is described.



TIP See [Sensor connections](#) for a complete list of sensor connections.

14.1 Power considerations

The MRL-IE provides analog sensor supplies of 500 mA at 5 V, 12/14 V and at SW2 each, totaling 1.5 A at 12 V supply voltage.



NOTE Some digital sensors may require a supply current >500 mA. If such sensors are connected to the MRL-IE, they need to be powered by an external power supply with a sufficient source current.

14.2 Analog measurements

With the MRL-IE the following signal types can be measured:

ID	Setting	Description
1	Voltage 2.5 V	Single ended voltage input 0 ... 2.5 V
2	Diff volt. 2.5 V	Differential voltage input 0 ... 2.5 V
3	Diff volt. 1.25 V	Differential voltage input 0 ... 1.25 V
4	Diff volt. 0.311 V	Differential voltage input 0 ... 0.311 V
5	Diff volt. 0.032 V	Differential voltage input 0 ... 0.032 V
6	R meas < 100k	Measures a resistance <100 k Ω
7	R meas < 3k	Measures a resistance <3 k Ω
8	R meas < 300	Measures a resistance <300 Ω
9	4...20 mA	Current input 4 ... 20 mA
10	PT1000	Measures the temperature of a PT1000 temperature sensor

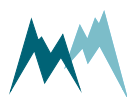

ID	Setting	Description
11	NTC (2k2)	Measures the temperature of a 2k2 NTC-thermistor
12	AD592	Measures the temperature of an AD592 temperature sensor
13	PT100	Measures the temperature of a PT100 temperature sensor

The signals received from a sensor are wired in the MRL-IE as illustrated in Figure 9.

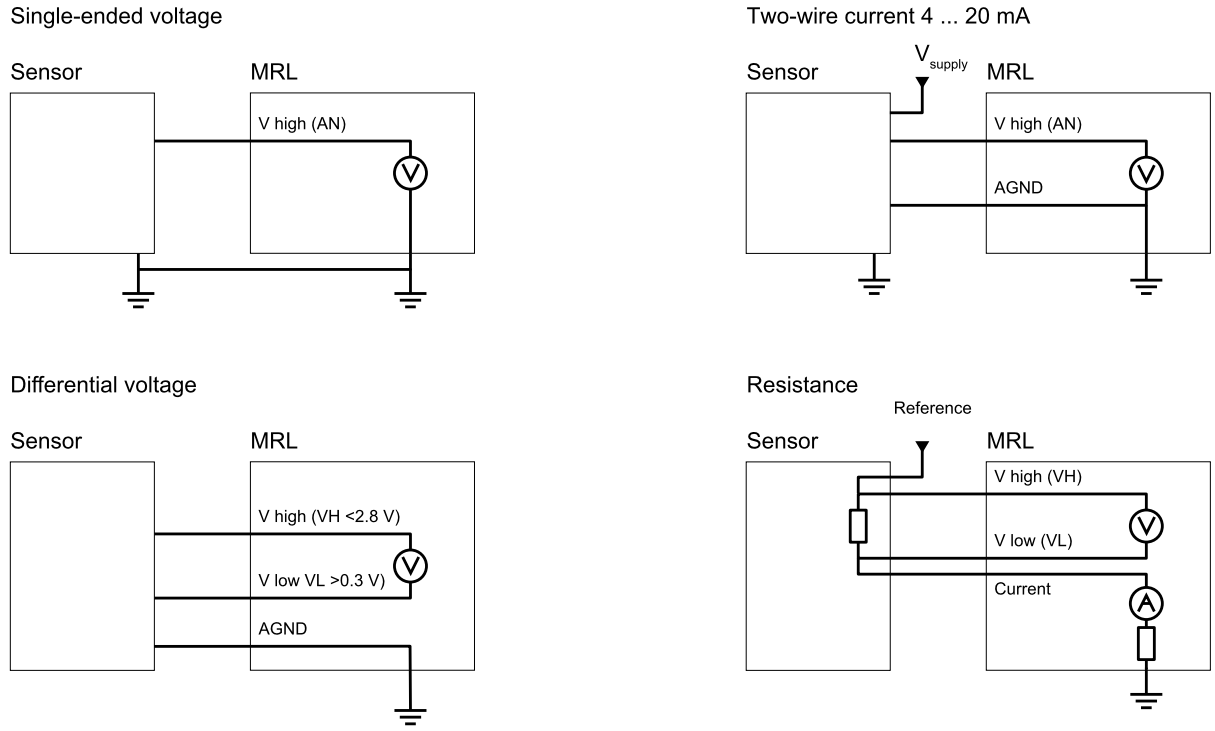

Figure 9 Internal wiring of analog MRL-IE inputs

14.2.1 Principals

The illustration below shows a sequence of two measurement cycles of three analog inputs (AN1, AN2 and AN3) and switched power supply.

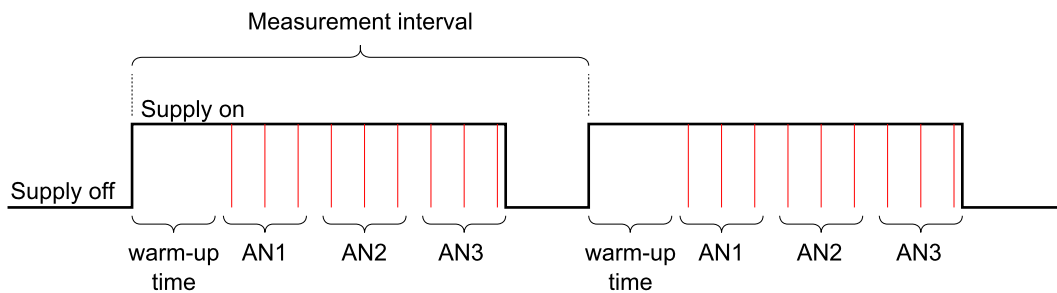

Figure 10 Principal of analog measurements

At the start of each measurement interval the sensor power supply is switched on. After the specified **Warm-up time** each of the three analog inputs is measured sequentially 3x at the sampling rate defined in **ADC - conv. Rate**. After each measurement has been completed, the sensor power supply is switched off.

The speed of the analog measurements can be set in **ADC - conv. Rate**. If **ADC filter** is activ the input is measured 3x and the data logger returns the statistic specified in **ADC filter**.

The measurement interval of all sensors is specified in **Measurement Interval**.

14.2.2 Single ended voltage measurement

A total of eight single ended voltages can be measured with the MRL-IE. **Figure 11** illustrates the wiring of a temperature and relative humidity sensor for single ended measurements with two analog inputs.

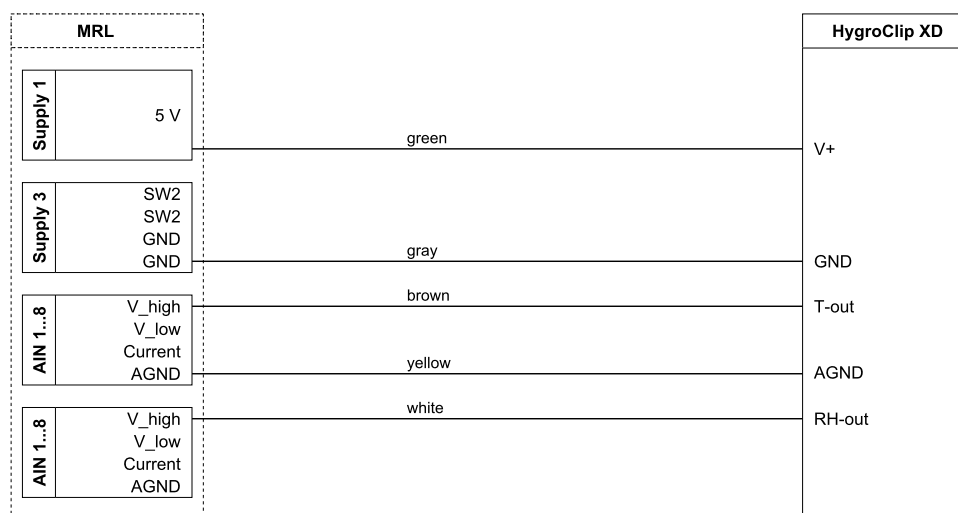
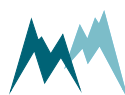

Figure 11 Wiring of a single ended voltage measurement (T/rH-sensor)

In this example, the **AIN 1 signal type** in the **Analog inputs** menu has to be set to Voltage 2.5 V.

The T/rH-sensor in this example can be configured in **Measurement table** as follows:

	Function	Identifier	Unit	Decimals	Scale	Offset		S-TYP	S-NUM	S-MEA	S-ADD
01	actual	Air Temperature	°C	2	100	-40	Adjustment Test	AIN		AIN 1	
02	actual	Humidity	%	1	100	0	Adjustment Test	AIN		AIN 2	



14.2.3 Differential voltage measurement

All analog inputs AIN1 ... AIN8 can also be configured as differential voltage inputs. The wiring of a pyranometer with a 0...100 mV output is illustrated in Figure 12.

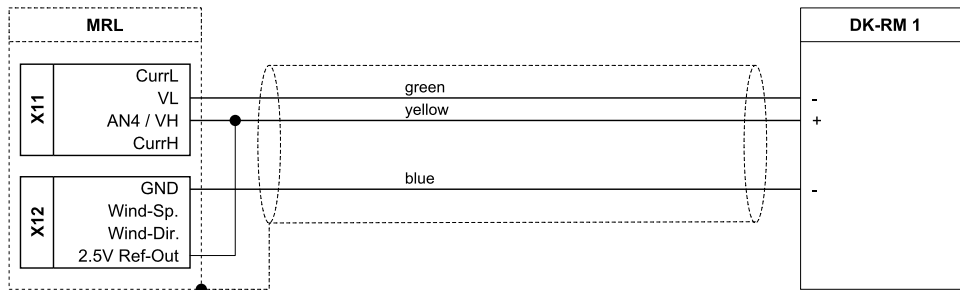

Figure 12 Wiring of differential voltage measurement (pyranometer)

In this example, the AIN 1 signal type in the Analog inputs menu has to be set to Diff volt. 0.311 V.

The pyranometer in this example is configured in Measurement table as follows:

Function	Identifier	Unit	Decimals	Scale	Offset	S-TYP	S-NUM	S-MEA	S-ADD	
01	actual	Global radiation	W/m ²	2	125000	0	Adjustment	Test	AIN	AIN 1

14.2.4 Current measurement

All analog inputs AIN1 ... AIN8 can also be configured as current inputs. As an example, the wiring of a infrared temperature sensor with an output of 4...20 mA and a measurement range of -50...50 °C is illustrated in Figure 13.

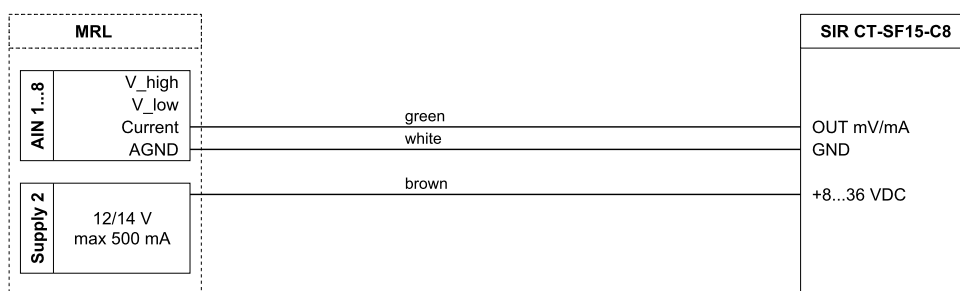
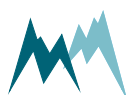

Figure 13 Wiring of sensor with current output (infrared temperature sensor)

In this example, the AIN 1 signal type in the Analog inputs menu has to be set to 4...20 mA.

The infrared temperature sensor in this example is configured in Measurement table as follows:



	Function	Identifier	Unit	Decimals	Scale	Offset		S-TYP	S-NUM	S-MEA	S-ADD
01	actual	Temperature	°C	2	6,25	-75	Adjustment	Test	AIN	AIN 1	

The given [Scale](#) and [Offset](#) values result from the 4...20 mA sensor output, the measurement range of the sensor and the chosen 100 Ω shunt resistor.

14.2.5 Resistance measurement

All analog inputs AIN1 to AIN8 can be used to measure resistances. As an example, the wiring of a 4-wire PT1000 temperature sensor is illustrated in [Figure 14](#).

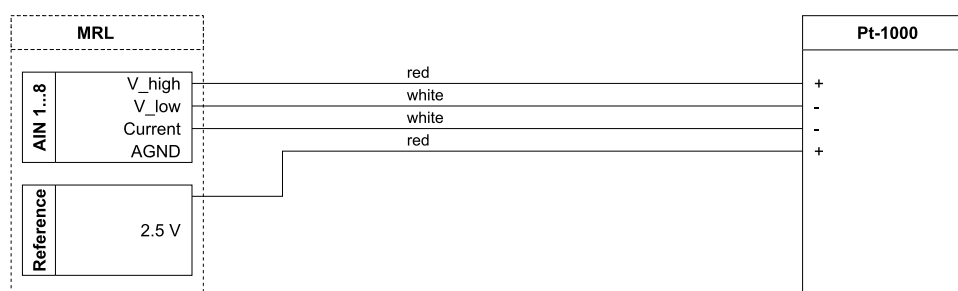

Figure 14 Wiring of resistance measurement (4-wire PT1000)

In this example, the [AIN 1 signal type](#) in the [Analog inputs](#) menu has to be set to PT1000.

The PT1000 in this example is configured in [Measurement table](#) as follows:

	Function	Identifier	Unit	Decimals	Scale	Offset		S-TYP	S-NUM	S-MEA	S-ADD
01	actual	Temperature	°C	2	1	0	Adjustment	Test	AIN	AIN 1	

As a Pt1000 sensor is already linearized, [Scale](#) and [Offset](#) need not to be changed.

14.3 Counter & frequency measurements

The MRL-IE is equipped with one universal counter input and one counter input dedicated to wind speed measurements with an anemometer.

14.3.1 Counting events

The counter input can be used to record counts of different devices.

As an example, the wiring of a tipping bucket rain gauge is illustrated in [Figure 15](#).

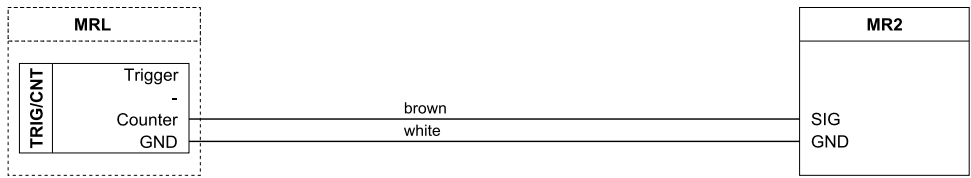

Figure 15 Wiring of a counter input (tipping bucket rain gauge)

The rain gauge in this example is configured in [Measurement table](#) as follows:

	Function	Identifier	Unit	Decimals	Scale	Offset		S-TYP	S-NUM	S-MEA	S-ADD
01	intens.	Precipitation	mm	2	0,2	0	Adjustment	Test	COUNT		



NOTE The acquired counter value is stored in the [Interval statistics function](#).

14.3.2 Frequency measurement

The wind speed input of the MRL-IE – generally used for wind speed measurements – measures the frequency of an incoming signal. [Figure 16](#) illustrates the wiring of a combined wind speed/direction sensor.

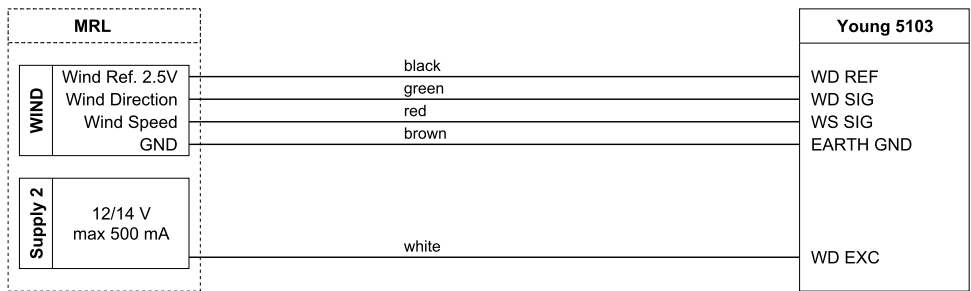
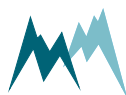

Figure 16 Wiring of a frequency input (combined wind speed/direction sensor)

The wind sensor in this example is configured in [Measurement table](#) as follows:

03	meanval	Wind Speed	m/s	2	0.098	0	Adjustment	Test	WIND	speed	
04	maximum	Wind Speed	m/s	2	0.098	0	Adjustment	Test	WIND	speed	
05	meanval	Wind Direction	°	1	1.44	0	Adjustment	Test	WIND	direct.	



14.4 RS-485

The MRL-IE is equipped with a RS-485 port to acquire sensor measurements.

14.4.1 Principles

The example below illustrates the acquisition of measurement values from three digital sensors with the same measurement duration.

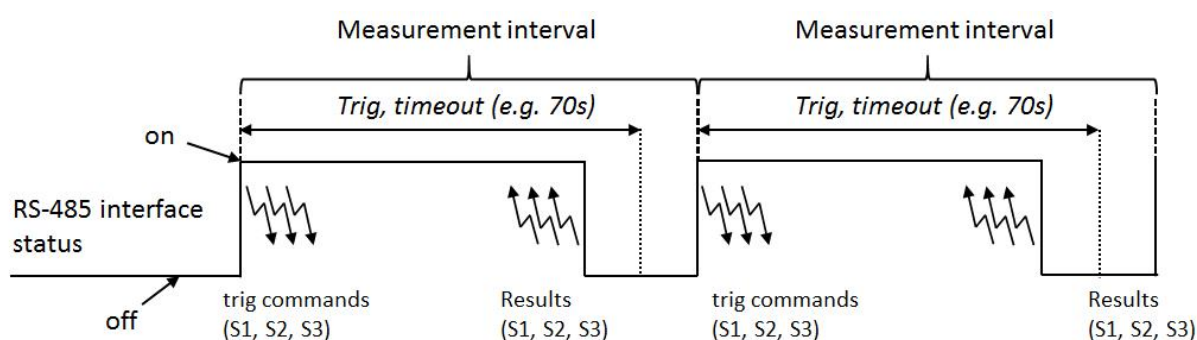

Figure 17 Principal of data acquisition by RS-485

In polling mode the MRL-IE activates the RS-485 interface at the beginning of each measurement interval and sends a measurement command to the addressed sensors. If this command is not confirmed by a sensor it is re-sent a 2nd or 3rd time. As soon as all measurements have been completed and the requested results have been received within **Timeout**, the RS-485 interface is switched off automatically and remains idle until the next measurement interval.



NOTE

If multiple sensors are connected to a MRL-IE, the measurement values must be polled in sequence to avoid data transmission conflicts. To do so, set **Polling delay** to a few seconds. As a result, the MRL-IE waits for the duration of **Polling delay** before it requests the data of the next sensor.

The **Polling delay** and the measurement duration of every sensor must match the duration of **Timeout**. If **Timeout** is too short, the MRL-IE may not receive all measurement values.

For example, sensor one has a measurement duration of 10 seconds, sensor two has a measurement duration of 30 seconds and **Polling delay** is 2 seconds, **Timeout** should be at least $10 + 2 + 30 = 42$ seconds, plus a few seconds for processing delays.

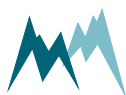

14.4.2 Multiple RS-485 devices

Multiple Sommer-sensors can be connected to the RS-485 port of the MRL-IE, provided each digital sensor has a unique address.



ATTENTION If multiple Sommer-sensors need to be connected, assign a unique address to each device! To do so, connect each sensor individually and set its address.

14.4.3 Find RS-485 devices with Commander

The Commander can be used to connect and manage Sommer RS-485 devices connected to the MRL-IE data logger. Follow the steps below to do this:

1. Connect your RS-485 devices to the +RS485A/-RS485B ports of the MRL-IE and make sure all devices are powered.
2. Establish a connection with the MRL-IE as explained in [Connect the MRL-IE to a PC](#).
3. Define a station as describes in [Create a station manually](#).
4. In the [Parameters \(F2\)](#) tab download the parameters of the MRL-IE.
5. Set [Enable network scan](#) to *on*.
6. Make sure the connection to the MRL-IE is not active (no green icon in the top-right corner). In the [Stations \(F7\)](#) tab click [Scan devices](#). The Commander will now search for all RS-485 devices connected to the data logger and will add them to the station information.

Now, the parameter lists of all devices can be downloaded and the configurations be adapted.

14.4.4 Reading data from a Sommer RS-485 device

Various sensing devices perform measurements autonomously and send out the results on request. The SOMMER IDS-20 Ice detection system is an example of such a device. It detects icing of a surface with a capacitive transducer and is used, for example, in the wind industry and in aviation to detect ice loads and icing events.

The IDS-20 performs measurements autonomously at an interval of 60 seconds. The acquired data can be read with the MRL-IE by wiring the data logger according to [Figure 18](#).



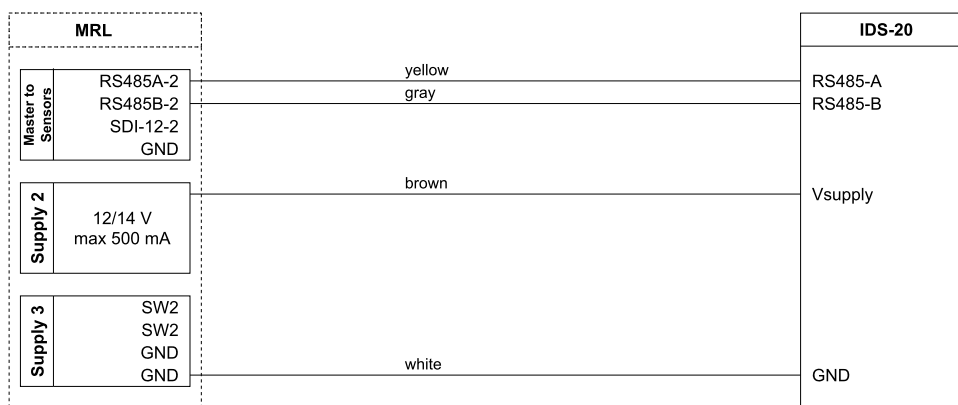

Figure 18 Wiring of IDS-20 ice detection sensor with RS-485 interface

The IDS-20 in this example is configured in **Measurement table** as follows:

	Function	Identifier	Unit	Decimals	Scale	Offset	S-TYP	S-NUM	S-MEA	S-ADD
01	actual	Ice	mm	as S		0	Adjustment Test SBP	1	7	TD
02	actual	Ice rate	mm/h	as S		0	Adjustment Test SBP	1	9	
03	actual	Dep point	°C	as S		0	Adjustment Test SBP	1	3	

To poll the data of the sensor, **Polling** must be *Off*. Also, note the command TD (trigger data) in the **S-ADD** field: this command requests the data from the IDS-20 device and needs to be set in the first variable acquired from the sensor.

To match this setup, the **Measurement trigger** of the sensor must be set to *Interval* (if this settings is available), and the output time (in sub-menu **RS485 protocol**) to *Just per command*.

Note that in this example only three variables of the IDS-20 are recorded. The device provides an extended list of variables that can be polled by the data logger.



ATTENTION The measurement time of different digital sensors varies considerably. Please consult the sensor manual and adjust **Timeout** accordingly! See also Note in **RS-485** above.

14.4.5 Reading data in MIO-format

Some older Sommer sensors like the USH-8 send data in the MIO-format (multi-in-out) which is structured as in the following example:

```
I04124874-011350148960519;
```



	Format	Description
Identifier	I	I identifies an output string
Device number	04	
System key	12	
Measurement value 1	4874	Level in mm (4 digits)
...	...	Measurement values 2...4 (4 digits each)
Checksum	0519	
End character	;	

To read data strings in MIO-format [Measurement table](#) has to be configured as follows:

Function	Identifier	Unit	Decimals	Scale	Offset	S-TYP	S-NUM	S-MEA	S-ADD		
01	actual	Level	mm	as S	0	Adjustment	Test	MIO	4	1	

In this example the first measurement value (level) is read from the sensor with device number 04.



ATTENTION The system keys of the sensor and the MRL-IE must be the same! In the example above the system key is 12. Set [System key](#) of the MRL-IE to 12 as well, or adapt the key of the sensor.

14.4.6 Trigger measurements of a Sommer RS-485 device

In many applications it is preferred that the MRL-IE triggers the sensor measurements. As an example, the SOMMER SQ-U water discharge sensor can be set into triggered mode. Once it has received the trigger command, the sensor performs the measurement and returns the acquired data to the MRL-IE. The wiring for this example is shown in [Figure 19](#).

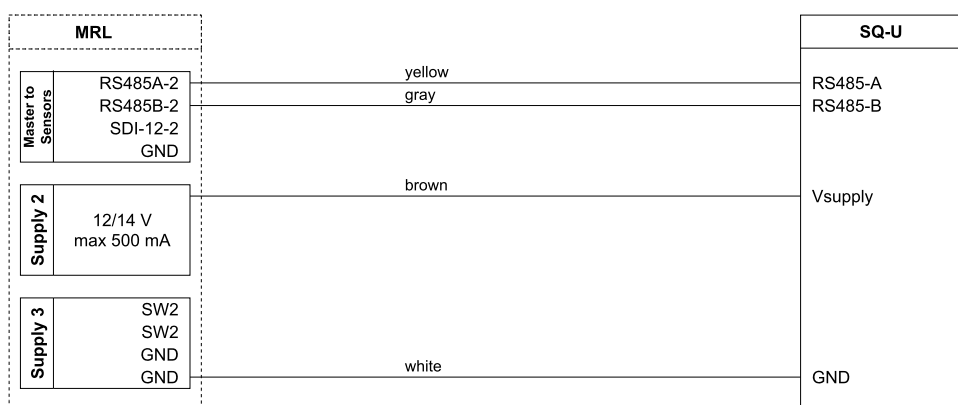

Figure 19 Wiring of SQ-X water discharge sensor with RS-485 interface

The SQ-U in this example is configured in [Measurement table](#) as follows:

	Function	Identifier	Unit	Decimals	Scale	Offset		S-TYP	S-NUM	S-MEA	S-ADD
01	actual	Water level	m	as S		0	Adjustment Test	SBP	1	2	
02	actual	Velocity	m/s	as S		0	Adjustment Test	SBP	1	3	
03	actual	Discharge	m ³ /s	as S		0	Adjustment Test	SBP	1	5	

Additionally, [Polling](#) must be set to *On*!

To match this setup, the [Measurement trigger](#) of the sensor must be set to *SDI-12/RS485*, and the output time (in sub-menu [RS485 protocol](#)) to *After measurement*.

Note that in this example only three variables of the SQ-U are recorded. The device provides an extended list of variables that can be read by the data logger.



NOTE Alternatively, the SQ-U can be set to acquire measurements in its own interval. See [Reading data from a Sommer RS-485 device](#) for configuration.

14.5 SDI-12

SDI-12 (Serial Data Interface at 1200 Baud) is a serial data communication standard for interfacing multiple sensors with a single data recorder. The MRL-IE complies with SDI-12 Version 1.3.

The MRL-IE is equipped with two SDI-12 ports. The port on terminal [Masters to Sensors](#) operates as an SDI-12 master, and the port on terminal [Slave to COM](#) as an SDI-12 slave.

The functions in the parameter menu [SDI-12 Master](#) offers some helpful functions to query SDI-12 sensor addresses, to test communication and to handle extended SDI-12 commands..



14.5.1 Principles

The example below illustrates how the MRL-IE triggers the measurements and requests the results from three SDI-12 sensors.

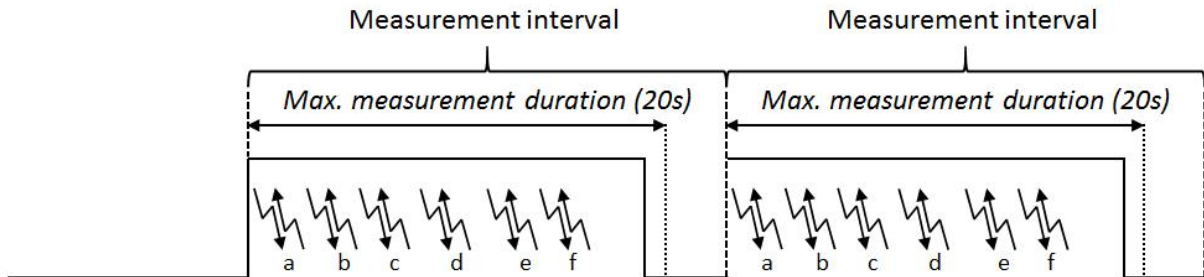

The commands and the received responses are as follows:

1. 0M! Response: 00013<CR><LF> 3 values are available in 1 second
2. 0D0! Response: 0+1.1+2.2+3.3>><CR><LF> 3 values: 1.1, 2.2, 3.3
3. 1M! Response: 10022<CR><LF> 2 values are available in 2 seconds
4. 1D0! Response: 1+4.4+5.5<CR><LF> 2 values: 4.4, 5.5
5. 2M! Response: 20031<CR><LF> 1 value is available in 3 seconds
6. 2D0! Response: 2+6.6<CR><LF> 1 value: 6.6

At the beginning of each measurement interval the MRL-IE sends an M! command to the first sensor. The sensor answers by returning the number of available measurements and the measurement duration. After the required measurement time the MRL-IE sends a D! command to request the measurement results. This sequence is repeated for the other two sensors before the next measurement interval starts.

The MRL-IE supports all standard SDI-12 commands. See S-ADD in [Measurement table](#) for a full list of these commands. For a detailed description on SDI-12 communication please refer to www.sdi-12.org.



TIP If you need to know more about how to program multiple M! and D! commands please see the example in [Send multiple SDI-12 requests](#).

14.5.2 Measurements with an SDI-12 sensor

An SDI-12 sensor is wired to the MRL-IE as shown in [Figure 20](#).

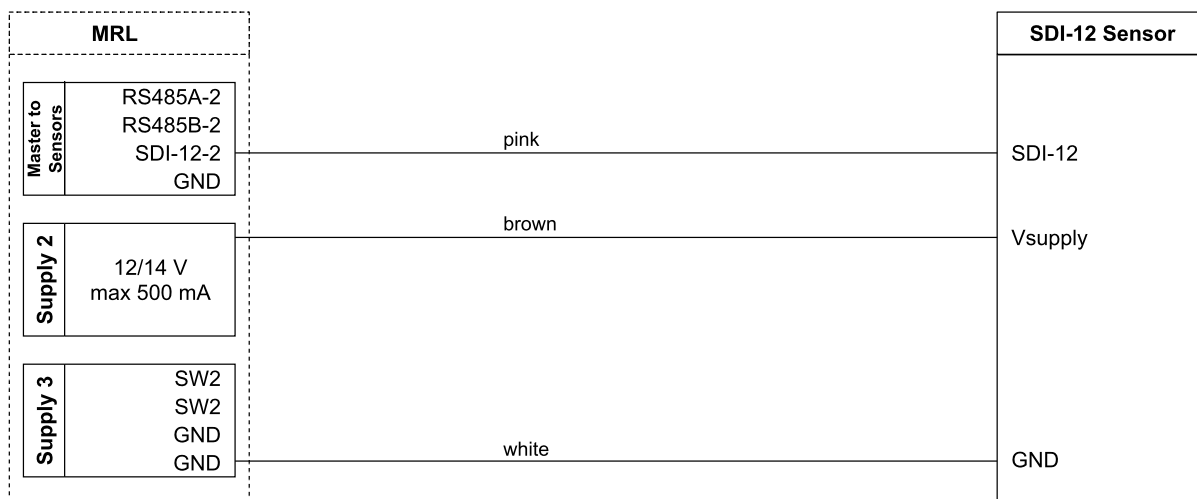

Figure 20 Wiring of a SDI-12 sensor

An SDI-12 sensor is configured in [Measurement table](#) as in the following example:

	Function	Identifier	Unit	Decimals	Scale	Offset		S-TYP	S-NUM	S-MEA	S-ADD
01	actual	Water Level	m	as S		0	Adjustment Test	SDI12	1	2	
02	actual	Velocity	m/s	as S		0	Adjustment Test	SDI12	1	3	
03	actual	Discharge	m ³ /s	as S		0	Adjustment Test	SDI12	1	5	

To enable data acquisition via SDI-12, **S-TYP** has to be set to *SDI12*, **S-NUM** to the SDI-12 address of the sensor and **S-MEA** to the position of the required measurement value in the data string.

To check the correct wiring between the MRL-IE and SDI-12 sensors, and to request the addresses of these sensors click on [Sensor search](#) in the [SDI-12 Master](#) menu. This function then searches for any connected SDI-12 sensors and lists their addresses and identifications. To change a sensor address click [Change sensor address](#).



NOTE

Please consider that SDI-12 measurements of multiple sensors are performed sequentially. To determine the total measurement time, add the measurement times of all sensors!

Make sure [Max. measurement duration](#) is long enough to capture the SDI-12 measurements. Be aware that some sensors need long warm-up times, which requires adequate [Max. measurement duration](#) and an appropriate [Measurement Interval](#).

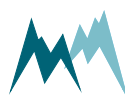



NOTE The parameter **Max. measurement duration** is important to allow the MRL-IE to switch into power saving mode in case a sensor has a failure.

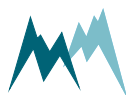

15 Signal output examples

As listed in [What can I do with it?](#) the MRL-IEa provides multiple signal output options. The most common are described in this section.

15.1 Current output

In this example the measurement values of a temperature and humidity sensor is applied to the 4 ... 20 mA outputs of the MRL-IEa. The settings of [Measurement table](#) and [Overview \(MRL-IEa\)](#) are shown below.

	Function	Identifier	Unit	Decimals	Scale	Offset		S-TYP	S-NUM	S-MEA	S-ADD
01	actual	Air Temperature	°C	2	100	-40	Adjustment	Test	AIN	AIN 1	
02	actual	Humidity	%	1	100	0	Adjustment	Test	AIN	AIN 2	

	Identifier	Output status	Channel allocation	4 mA value	4-20 mA span
01	IOUT 1	always on	1	-30	90
02	IOUT 2	always on	2	0	100
03	IOUT 3	off			
04	IOUT 4	off			



NOTE The range of the 4 ... 20 mA output is specified in **4-20 mA span**. In the example above, the current output ranges from -30 to +60 °C, which corresponds to a span of 90°C.

15.2 Pulse output

In this example the water flow of a canal is recorded with a SOMMER SQ-U discharge sensor. To display the total volume with an analog meter the MRL-IEa converts the flow value to a corresponding number of pulses that are applied to the digital output.

	Function	Identifier	Unit	Decimals	Scale	Offset		S-TYP	S-NUM	S-MEA	S-ADD
01	actual	Water level	m	as S		0.0	Adjustment	Test	SBP	1	2
02	actual	Velocity	m/s	as S		0.0	Adjustment	Test	SBP	1	3
03	actual	Flow rate	m ³ /s	as S		0.0	Adjustment	Test	SBP	1	5
04	actual	Flow	m ³	as S		0.0	Adjustment	Test	RECYC	3	PS

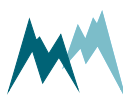

Identifier	Output status	Measurement channel nr.	Limit type	Limit value	Hysteresis	Quantity per impuls	min. impulse width	Output	
01	DIG-OUT 1	Impulse output		4		1 */imp	30 ms	measurement value	Test
02	DIG-OUT 2	off							Test
03	DIG-OUT 3	off							Test
04	DIG-OUT 4	off							Test
05	DIG-OUT 5	off							Test
06	DIG-OUT 6	off							Test

The water volume that passes the discharge sensor in one measurement interval is specified in the measurement table with index *4* and has the unit m^3 (the command *PS* in *S-ADD* returns the number of seconds of one measurement interval).

After each measurement interval the flow is returned on DIG-OUT 1 with $1 \text{ m}^3/\text{impulse}$. For example, a flow of 12.3 m^3 generates 12 impulses. The remaining volume of 0.3 m^3 is added to the next interval.

If *Quantity per impulse* would be set to 10 */imp , only one impulse would be generated and the remaining 2.3 m^3 would be added to the next interval.

15.2.1 How to simulate pulse output

Each entry in *Digital outputs (MRL-IEa only)* has a *Test* button to simulate the specified pulse output. This allows testing of a connected display or data acquisition system.

By clicking *Test*, a window opens and the maximum number of pulses the MRL-IEa can return with the present settings are displayed.



EXAMPLE

In this example the *Measurement Interval* is set to *1* minute and the *min. impulse width* in *Digital outputs (MRL-IEa only)* to *500 ms*. As each impulse of high voltage is followed by a low-voltage lapse of the same length, $60 \text{ s}\cdot\text{min}^{-1} / (2 \times 0.500 \text{ s}) = 60$ pulses can be applied to the digital output every minute.

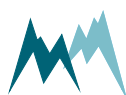

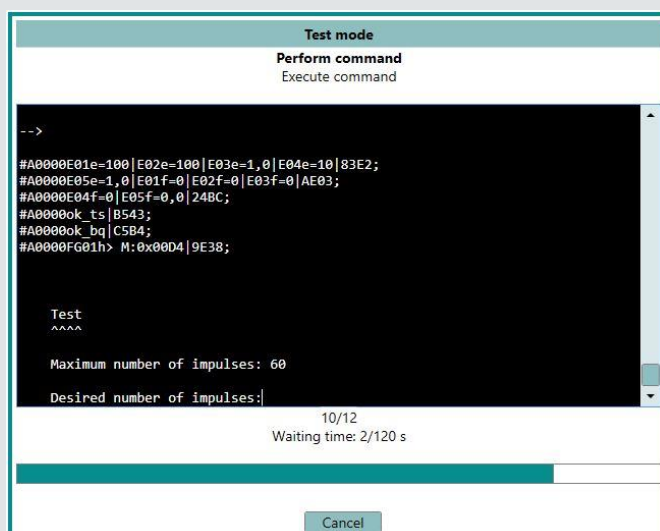

In the pop-up window you can now enter the desired number of pulses that are applied to the digital output.



EXAMPLE

Following the example above, by entering a desired number of 20 impulses the digital output of the MRL-IEa is activated and the pulses are applied. After all pulses have been sent `Simulation done!` is displayed.

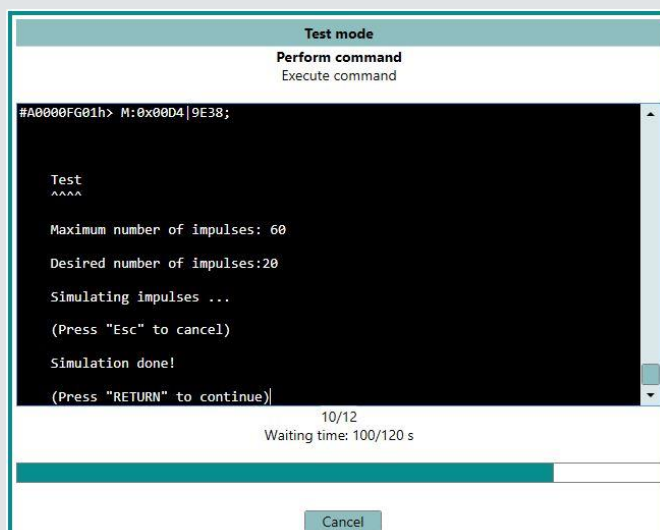

15.3 Limit monitoring

The MRL-IEa can be used to monitor a variable with respect to a limit value. In this example the discharge of a river is monitored with a Sommer SQ-U water discharge sensor. The MRL-IEa shall return a high-voltage signal as soon as the discharge exceeds $9 \text{ m}^3/\text{s}$.

To implement this task, the **Limit value** in **Digital outputs (MRL-IEa only)** is set to **9** and **Hysteresis** to **0.5**. As soon as the water discharge exceeds $9 \text{ m}^3/\text{s}$ the digital output **DIG-OUT 1** is set to *high*. This status remains until the water discharge drops below $9.0 \text{ m}^3/\text{s} - 0.5 \text{ m}^3/\text{s} = 8.5 \text{ m}^3/\text{s}$ again.

	Function	Identifier	Unit	Decimals	Scale	Offset		S-TYP	S-NUM	S-MEA	S-ADD
01	actual	Water level	m	as S		0	Adjustment Test	SBP	1	2	
02	actual	Velocity	m/s	as S		0	Adjustment Test	SBP	1	2	
03	actual	Discharge	m^3/s	as S		0	Adjustment Test	SBP	1	5	

	Identifier	Output status	Channel allocation	Limit type	Limit value	Hysteresis	min. impulse width	
01	DIG-OUT 1	Limit monitor	3	Limit overrun	9	0,5		Test
02	DIG-OUT 2	off						
03	DIG-OUT 3	off						
04	DIG-OUT 4	off						
05	DIG-OUT 5	off						
06	DIG-OUT 6	off						

The hysteresis prevents frequent switching of the digital output when the monitored variable fluctuates around the limit value. The graph below illustrates this situation.

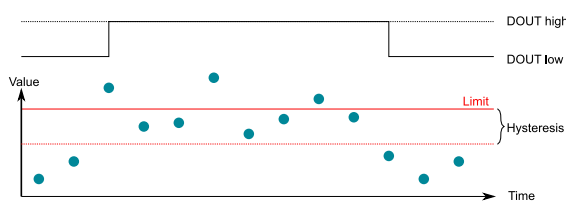

16 Parameter definitions

A	Measurement trigger	113
B	Measurement Interval	113
C	Interval statistics function	114
D	Measurements, max. number	114
E	Aux measurements, max. number	114
F	Measurement table	115
G	Technics	121
H	Region format	144
I	Special functions	145

A Measurement trigger

`generic-measurement-trigger`

Measurements are initiated by one of the options listed in the table below.

The commands to trigger measurements via RS-485 and SDI-12 are described in [Communication](#).

Measured data are either returned directly after the measurement or can be requested by commands via the RS-485 or SDI-12 interface. The format of the returned data can be configured in the sub-menu [Protocol type](#).

ID	Option	Description
1	Interval (default)	Measurements are initiated in a specified interval.
2	TRIG input	Measurements are triggered by the positive edge of a DC-voltage signal applied to the TRIG input (low: 0 ... 0.6 V, high: 2.2 ... 28 V, pulse duration must be ≥ 500 ms, delay between pulses must be ≥ 500 ms)
3	SDI-12/RS-485	Measurements are externally triggered by commands via RS-485 or SDI-12 from ,e.g. a data logger.
4	all allowed	Measurement is triggered by all options mentioned above.

B Measurement Interval

`generic-measurement-interval`

An internal measurement interval can be set for the MRL-IE. If selected in menu item [Measurement trigger](#), measurements are performed in the defined interval. However, a measurement is always completed before a new one is initiated.

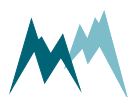

Value range	Default	Units
00:00:02 ... 12:00:00	00:05:00	-

C Interval statistics function

mrl-interval-statistics-function

The time-window for which the statistic selected in **Function** of **Measurement table** is calculated.

Value range	Default	Units
00:00:10 ... 12:00:00	00:01:00	sec

D Measurements, max. number

mrl-measurements-max-number

The number of variables the MRL-IE records. If the MRL-IE is shipped with additional instruments, SOMMER Messtechnik pre-configures the required variables. The variables are configured in **Measurement table** and their number can be increased to 99 (including **Aux measurements, max. number**)

Value range	Default	Unit
0 ... 99	4	-

E Aux measurements, max. number

mrl-aux-measurements-max-number

The number of auxiliary variables the MRL-IE records. Auxiliary variables are configured like regular variables, except that they are not stored in memory and are only visible in the Commander **Measurement** tab, the terminal window or the logger display. In **Measurement table** they are numbered downwards from 99.

Auxiliary variables may be used to monitor limit violations, trigger messages or to display a variable with a second, different unit or a different offset. They are also used to combine different variables to a new one.

Value range	Default	Units
1 ... 99	0	-

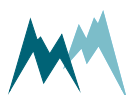

F Measurement table

`generic-measurement-table`

In the measurement table the recorded variables are selected. By default, the measurement table contains the following variables:

Index	Measurement value
1	Variable 01 ^a
2	Variable 02 ^a
3	Variable 03 ^a
...	...
97	Variable 97 ^a
98	Variable 98 ^a
99	Variable 99 ^a

^aAccording to the acquired variables

Each entry of the measurement table is configured by the parameters described below:

Identifier

`generic-measurement-table-identifier`

User defined variable name. Max. 17 characters long.

Unit

`generic-measurement-table-unit`

The unit of the selected variable. Max. 7 characters long.

Decimals

`generic-measurement-table-decimals`

The number of decimal places assigned to the selected variable. The following options are available:

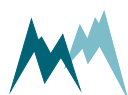

ID	Decimals	Description								
1...5	1...5	number of decimal places assigned to the selected variable								
6	none	no decimal places								
7	as S	<p>For a connected serial sensor the number of decimal places of the sensor output is adopted.</p> <p>For a connected analog sensor the following rules apply:</p> <table border="1"> <thead> <tr> <th>Input type</th> <th>Decimal places</th> </tr> </thead> <tbody> <tr> <td>Voltage, resistance</td> <td>4</td> </tr> <tr> <td>Frequency of wind sensor</td> <td>1</td> </tr> <tr> <td>Direction of wind sensor</td> <td>1</td> </tr> </tbody> </table>	Input type	Decimal places	Voltage, resistance	4	Frequency of wind sensor	1	Direction of wind sensor	1
Input type	Decimal places									
Voltage, resistance	4									
Frequency of wind sensor	1									
Direction of wind sensor	1									

Scale

`generic-measurement-table-scale`

The slope applied to the selected variable. Only available if **Decimals** is set to 1...5 or none. If **Decimals** is set as S (as source), no scaling is applied.

Offset

`generic-measurement-table-offset`

The offset applied to the selected variable.

Adjustment

`generic-measurement-table-adjustment`

A measurement of the selected variable is triggered and the result displayed in a terminal window. If the measured value deviates from the correct value, the correct value can be entered. This adjusts the value in **Offset**. The factor in **Scale** is not affected by this correction.

Test

`generic-measurement-table-test`

A measurement of the selected variable is triggered and the result displayed in a terminal window.

S-TYP

`generic-measurement-table-s-typ`

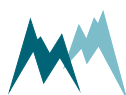

One of the following sensor (or source) types:

S-TYP	Description and S-MEA options
AIN	Analog input The input port is set in S-MEA with the following options: AN 1 . . . AN 8 Analog input 1 ... 8
WIND	Wind sensor The input is set in S-MEA with the following options: Speed Wind speed Direct. Wind direction
COUNT	Counter input See Counter & frequency measurements for details.
SDI12	SDI-12 input The sensor address is set in S-NUM , and the position of the measurement value within the output string is assigned in S-MEA . See SDI-12 for details.
SBP	SOMMER sensor that supports the SBP-protocol (via RS-485) The sensor address is set in S-NUM , and the position of the measurement value within the output string is assigned in S-MEA . See RS-485 for details.
MIO	SOMMER sensor that supports the MIO-protocol (via RS-485) The sensor address is set in S-NUM , and the position of the measurement value within the output string is assigned in S-MEA . See Reading data in MIO-format for details.
SYS	System variable The variable is set in S-MEA with the following options: Status A Number of triggers received on the TRIG- input within the Measurement Interval Status B not assigned Exep. A Diagnostic variable Exep. B Diagnostic variable HB Heartbeat (diagnostic variable) +Sup V Supply voltage 12V 14V Voltage of internal 12V / 14V power supply 5V Voltage of internal 5V power supply 2.5V Voltage of internal 2.5V power supply
RECYC	Performs an operation on the variable referenced in S-NUM and returns its result. See S-ADD for available operations.
RECYCM	Performs a mathematical operation between two variables referenced in S-NUM and S-MES , and returns its result. See S-ADD for available functions.

S-NUM

generic-measurement-table-s-num

Depends on the setting of **S-TYP**. For example 3 if **S-TYP** is set to **SPA-S**.

S-MEA

generic-measurement-table-s-mea

This setting depends on the selection of **S-TYP**. For example, if **S-TYP** is set to **SDI12**, **S-MEA** sets the position of the measurement variable within the SDI-12 string. See **S-TYP** for all available options.

S-TYP	S-NUM	S-MEA	Usage
SBP	Sensor address (0...99)	Position of variable in received data string (0...99).	Read value of digital sensor using SBP protocol.
MIO	Sensor address (0...99)	Position of variable in received data string (0...99).	Read value of digital sensor using MIO protocol.
SDI12	Sensor address (0...62)	Position of variable in received data string (0...99).	Read value of SDI-12 sensor.
RECYC	Measurement ID (0...99)	-	See table in S-ADD .
RECYCM	Measurement ID (0...99)	Measurement ID (0...99)	See table in S-ADD .

S-ADD

generic-measurement-table-s-add

Contains additional commands which are sent with a standard request to a sensor (or source), or which provide additional options for controlling measurements and handling results. The available commands depend on the settings of **Function**, **S-TYP** and **S-ADD**.

Function	S-TYP	S-ADD	Description
SUM	all	NR	No reset of summed variables at defined reset event.
SUM	all	MRx	Monthly reset of summed variables at day x, e.g MR1 for reset at 1st of month.
SUM	all	DD	Double data for summed variables at reset event; old and new values are stored.
all	SDI12	_Cn	Concurrent measurement command for measurements n (_C1 ... _C9).

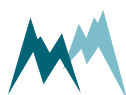

Function	S-TYP	S-ADD	Description
all	SDI12	CCn	Concurrent measurement command with CRC for measurements n (_CC1 ... _CC9).
all	SDI12	_Mn	Measurement command for measurements n, (_M1 ... _M9).
all	SDI12	MCn	Measurement command with CRC for measurements n, (_MC1 ... _MC9).
all	SDI12	_Rn	Read command for measurements n, (_R0 ... _R9).
all	SDI12	RCn	Read command with CRC for data n, (_RC0 ... _RC9).
all	SDI12	RD	Rain disdrometer data of Sommer Messtechnik RHD sensor.
all	SDI12	HD	Hail disdrometer data of Sommer Messtechnik HDI sensor.
all	SBP, MIO	SCx	Sub-channel x for MDL compatibility.
all	SBP, MIO	TD	Trigger data of a SBP or MIO device.
all	MIO	TF	Trigger fake. In MIO protocol ID's are often only string ID's and not real device ID's. TF marks the real device ID's.
all	all	SY	Synchronous storage: variable that is normally stored asynchronously is stored in the main storage interval, e.g. a counter input.
all	all	PV	<p>Values are returned on serial port RS-485-2 immediately after measurement. This may be used to send measurement values to another serial sensor as input.</p> <div style="display: flex; align-items: center;">  <div style="margin-left: 10px;"> <p>ATTENTION Make sure to use proper timing if data are also received over the RS-485-2 port.</p> </div> </div>
all	all	MAxx	<p>Moving average of xx values, where xx is 5, 12, 24, 48, 96.</p> <p>Note: Each command can only be applied once, i.e. one MA5, one MA12, ...!</p>

Function	S-TYP	S-ADD	Description
all	all	PS	Converts the measurement interval into seconds (PS), minutes (PM), hours (PH) and days (PD) and multiplies the it with the value of the variable.
all	all	PM	Generally used to calculate differences and intensities.
all	all	PH	For example, a sensor returns a flow rate with the unit m ³ /s. To return the total flow, set Function to Sum , the Unit to m ³ and S-ADD to PS . Here, the measurement interval is converted into seconds, multiplied with the measurement value and added to the flow.
all	all	PD	ATTENTION: Select the time unit that matches the unit of the variable!
all	RECYC	GS	Returns the limit status of the variable referenced in S-NUM . If a limit has been violated 1 is returned.
all	RECYC	VA	Applies look-up table A to variable referenced in S-NUM and returns the result.
all	RECYC	VB	Applies look-up table B to variable referenced in S-NUM and returns the result.
all	RECYCM	D+	Adds variables referenced in S-NUM and S-MEA .
all	RECYCM	D-	Subtracts variable referenced in S-MEA from S-NUM .
all	RECYCM	D*	Multiplies variables referenced in S-NUM and S-MEA .
all	RECYCM	D/	Divides variable referenced in S-NUM by S-MEA .
all	RECYCM	EX	Returns exponential of variable referenced in S-NUM (power to basis e).
all	RECYCM	PT _{y . y}	Returns potential of variable referenced in S-NUM to the power of y . y , e.g. a value of 2 with function PT3 . 0 returns 2³ = 8 .
all	RECYCM	DM	Returns the value of the variable referenced in S-MEA at the maximum or minimum of the variable referenced in S-NUM . Generally used to record the wind directions of wind gusts (direction maximum).

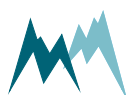



TIP Multiple commands can be entered by separating them with a space, e.g. D+ SY.

G Technics

G-A	SBP device addressing	121
G-B	RS485-1 (COM)	122
G-C	SDI-12 Slave	127
G-D	Additional settings	128
G-E	Inputs	130
G-F	Analog outputs (MRL-IEa only)	141
G-G	Digital outputs (MRL-IEa only)	142

G-A SBP device addressing

G-A-A	Device number	121
G-A-B	System key	121
G-A-C	Enable network scan	122

G-A-A Device number

`generic-rs-485-protocol-device-number`

The device number is used for the unique identification of the device in a bus system.

Value range	Default	Units
0...98	1 (default)	-

G-A-B System key

`generic-rs-485-protocol-system-key`

The system key defines the bus system of the device. Thus, different conceptual bus systems can be separated. Interfering bus systems occur if the remote radio coverage of two measurement systems overlap. In general, the system key should be set to 00.

Value range	Default	Units
0...99	0	-

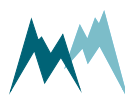

G-A-C Enable network scan

`generic-rs-485-port-network-scan-extension`

Optional detection of connected SOMMER sensors with the Commander software.

ID	Setting	Description
1	No	Detection of SOMMER devices connected to RS485-2 is deactivated.
2	Yes (default)	Detection of SOMMER devices connected to RS485-2 is activated.

G-B RS485-1 (COM)

G-B-A	Output protocol	122
G-B-B	Port	125

G-B-A Output protocol

G-B-A-A	Protocol type	122
G-B-A-B	Measurement output	123
G-B-A-C	Information	123
G-B-A-D	Wake-up sequence	123
G-B-A-E	Prefix holdback	124
G-B-A-F	MODBUS, set default	124
G-B-A-G	MODBUS, device address	124

G-B-A-A Protocol type

`generic-rs-485-protocol-output-protocol`

The type of the serial output protocol. The following options are available:

ID	Option	Description
1	Sommer (SBP) (default)	Sommer protocol; data values are returned with an index starting at 1. Multiple strings may be returned.
2	Standard	Standard protocol; data values are returned without an index in one string.
3	MODBUS	Modbus protocol

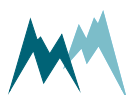



NOTE For MODBUS applications run `MODBUS, set default` to get the appropriate communication settings.

G-B-A-B Measurement output

`generic-rs-485-protocol-measurement-output`

Specifies the timing of the serial data output.

ID	Option	Description
1	Just per command	The output is only requested by commands via the RS-485 or SDI-12 interface.
2	Measured values push	Data are returned automatically after each measurement. interval.
4	Statistic push	Statistically aggregated data are returned after each statistics interval.

G-B-A-C Information

`generic-rs-485-protocol-information`

The main measurement values are always included in the data output string. Additionally, the auxiliary values can be included.

ID	Option	Description
1	Main values	Only the main values are returned.
2	& Aux values	Main values and auxiliary values are returned.

G-B-A-D Wake-up sequence

`generic-rs-485-protocol-wake-up-sequence`

Serial data can be transmitted to a recording device automatically without a request. However, many devices demand a wake-up sequence before they can receive and process data. The MRL-IE has the option to send a sync sequence and a prefix before data are transmitted. The following options are available:

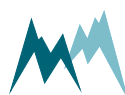

ID	Option	Description
1	Off	No wake-up sequence
2	Sync	The sync sequence UU~?~? is sent before the output string.
3	Prefix (default)	A blank with a time delay is sent before the output string.
4	Prefix & Sync	A blank with a time delay and the sync sequence UU~?~? is sent before the output string.

G-B-A-E Prefix holdback

`generic-rs-485-protocol-prefix-holdback`

The hold-back time defines the time delay between the prefix and the data string.

Value range	Default	Units
0...5'000	300	ms

G-B-A-F MODBUS, set default

`generic-rs-485-protocol-modbus-set-default`

Sets all parameters required for Modbus communication automatically. The following settings are adapted:

Parameter	Modbus setting
OP, measurement output	just per command
Output protocol (OP)	Modbus
MODBUS, device address	35
Sleep mode	Modbus, slow
Parity, stop bits	even par, 1 stop
Baud rate	19200
Flow control	off
Transmitter warm-up time	10 ms
Minimum response time	30 ms

G-B-A-G MODBUS, device address

`generic-rs-485-protocol-modbus-device-address`

Unique device address for the Modbus protocol.

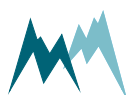

Value range	Default	Units
1...247	35	-

G-B-B Port

G-B-B-A	Baud rate	125
G-B-B-B	Parity, stop bits	125
G-B-B-C	Minimum response time	126
G-B-B-D	Transmitter warm-up time	126
G-B-B-E	Flow control	126

G-B-B-A Baud rate

`generic-rs-485-port-baud-rate`

The following transmission rates in bps (baud) can be selected:

ID	Option	Description
1	1'200	-
2	2'400	-
3	4'800	-
4	9'600 (default for sensors and data logger inputs)	-
5	19'200 (default if used with radio communication)	-
6	38'400	-
7	57'600	-
8	115'200 (default for data loggers)	-

G-B-B-B Parity, stop bits

`generic-rs-485-port-parity-stop-bits`

The following combinations of parity and stop bits can be selected:

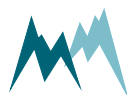

ID	Option	Description
1	No par, 1 stop (default)	No parity and 1 stop bit
2	No par, 2 stop	No parity and 2 stop bits
3	Even par, 1 stop	Even parity and 1 stop bit
4	Odd par, 1 stop	Odd parity and 1 stop bit

G-B-B-C Minimum response time

`generic-rs-485-port-minimum-response-time`

This setting avoids failures of half-duplex interfaces. For this purpose the response to a command is delayed by the selected time. Additionally, the response is also kept temporally compact.

Value range	Default	Units
0...2'000	10	ms

G-B-B-D Transmitter warm-up time

`generic-rs-485-port-transmitter-warm-up-time`

The transmitter warm-up time defines the time before data is sent.

Value range	Default	Units
0...2'000	10	ms

G-B-B-E Flow control

`generic-rs-485-port-flow-control`

Flow control for the defined application.

ID	Option	Description
1	Off	no flow control
2	XOFF-XON blocking (default)	XOFF-XON flow control, especially adapted for half-duplex systems
4	DFM-RC	Flowcontrol for Sommer Messtechnik DFM point-to-point radios.
5	DFM-TM	Flowcontrol for Sommer Messtechnik DFM tiny-mesh radios.

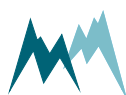

G-C SDI-12 Slave

G-C-A	SDI-12 address	127
G-C-B	SDI12 'M'-response	127

G-C-A SDI-12 address

`generic-sdi-12-address`

The address is a unique identifier of the sensor within a SDI-12 bus system.

Value range	Default	Units
0...9, a...z, A...Z	0	-

G-C-B SDI12 'M'-response

`generic-sdi-12-m-response`

Defines how an SDI-12 M-command received by the MRL-IE is answered if the requested number of measurement values exceeds 9. The following options are available:

ID	Parameter	Description
1	expand address	This option should only be used with SDI-12 standard V1.0. The measurement values can be requested with the commands <code>aD0!</code> , <code>aD1!</code> , ..., with a the sensor address. Max. 9 values are returned for each command.
2	just expand output	The M-request received by the MRL-IE is answered according to SDI-12 standard V1.3, which supports transmitting more than 9 measurement values per answer.
3	as at 'C' request	The M-request received by the MRL-IE is answered as if several C-requests were sent.
4	M1, M2, M3 split (default)	The M-request received by the MRL-IE is answered as if several <code>M_k</code> -commands were sent, with <code>k</code> depending on the number of measurement values to be transmitted (<code>M1</code> returns the first 9 measurement values, <code>M2</code> the second nine values, etc).

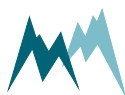

G-D Additional settings

G-D-A	Sommer ID	128
G-D-B	Sleep mode	128
G-D-C	Block size, data load	128
G-D-D	Internal low volt. disconnect	129
G-D-E	SommerXF starts with BOM	129

G-D-A Sommer ID

`generic-sommer-id`

The Sommer ID is used to define stations within the Commander software. The ID is preset in the device and corresponds to its serial number. SOMMER suggests to change the ID only, if a MRL-IE device is replaced. In such a case it can be practical to change the ID of the new device to the ID of the replaced device to guarantee data consistency. It is important that two devices that have the same combination of Sommer ID and Station ID, do NOT access the IP-Call server or MDS!

G-D-B Sleep mode

`generic-sleep-mode`

Defines the behavior of the MRL-IE between two measurements, provided the measurement interval is longer than the time of the measurement itself. The following options are available:

ID	Option	Description
1	MODBUS, fast	For MODBUS applications. The MRL-IE stays in normal mode. This option permits high data transmission rates, but increases power consumption.
2	MODBUS, slow	For MODBUS applications. The MRL-IE goes into idle mode and can be woken up by a command via the RS-485 interface with a low baud rate. This option reduces power consumption at lower data transmission rates.
3	Standard (default)	The MRL-IE goes into sleep mode and can be woken up by a command via the RS-485 interface only with a time delay. Option with the lowest power consumption.

G-D-C Block size, data load

`mrl-block-size-data-load`

The maximum amount of data transferred with one communication block requested by a data acquisition software.

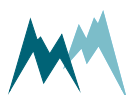

Value range	Default	Units
50...250	250	-

G-D-D Internal low volt. disconnect

mrl-internal-low-volt-disconnect

To prevent deep discharge of the MRL-IE batteries, the device switches off if the battery voltage drops below the specified limit. It then checks every hour if the battery has recuperated again and eventually switches back to normal measurement mode. The limit depends on the battery and the duration the battery has to supply the station without any recharge; consult the battery datasheet for more information.

Value range	Default	Unit
0...11	11	V



NOTE If set to *0*, deep discharge is not monitored! This may be applied when using an external charger with an external battery (no battery is connected to terminal X1).



ATTENTION Inappropriate setting of the voltage limit can seriously impair the continuous operation of the MRL-IE or even lead to a complete failure of the station! Once the battery voltage drops to **Internal low volt. Disconnect**, all power outputs of the MRL-IE incl. X20 are switched off.

G-D-E SommerXF starts with BOM

mrl-sommerxf-starts-with-bom

The BOM (Byte Order Mark) labels the downloaded data file to indicate that special characters within the file are coded.

ID	Setting	Description
1	On (default)	BOM is included in the data file.
2	Off	BOM is not included in the data file.

G-E Inputs

G-E-A	RS485-2	130
G-E-B	SDI-12 Master	135
G-E-C	Analog inputs	137
G-E-D	Additional meas. settings	140

G-E-A RS485-2

G-E-A-A	Sensor supply (always on)	130
G-E-A-B	SBP sensor feedback	130
G-E-A-C	Port	132
G-E-A-D	Trigger	134

G-E-A-A Sensor supply (always on)

mrl-12v-sensor-supply-always-on

Sets the 12V sensor supply.

ID	Setting	Description
1	Off (default)	The sensor supplies 12V / 14V and SW2 are off.
2	SW2	The sensor supply SW2 is active.
3	12V / 14V	The sensor supply 12V / 14V is active.
4	12V / 14V & SW2	Both sensor supplies 12V / 14V and SW2 are active.



NOTE If one of the listed sensor supplies has been selected, it also remains active during the sleep mode of the MRL-IE.

G-E-A-B SBP sensor feedback

The parameters in this menu define the transmission of measurement data to serial RS-485 sensors operating with the Sommer bus protocol (SBP).

G-E-A-B-A Measurement output

generic-rs-485-protocol-measurement-output

Specifies the timing of the serial data output.

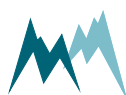

ID	Option	Description
1	Just per command	The output is only requested by commands via the RS-485 or SDI-12 interface.
2	Measured values push	Data are returned automatically after each measurement. interval.
4	Statistic push	Statistically aggregated data are returned after each statistics interval.

G-E-A-B-B Information

`generic-rs-485-protocol-information`

The main measurement values are always included in the data output string. Additionally, the auxiliary values can be included.

ID	Option	Description
1	Main values	Only the main values are returned.
2	& Aux values	Main values and auxiliary values are returned.

G-E-A-B-C Wake-up sequence

`generic-rs-485-protocol-wake-up-sequence`

Serial data can be transmitted to a recording device automatically without a request. However, many devices demand a wake-up sequence before they can receive and process data. The MRL-IE has the option to send a sync sequence and a prefix before data are transmitted. The following options are available:

ID	Option	Description
1	Off	No wake-up sequence
2	Sync	The sync sequence UU~?~? is sent before the output string.
3	Prefix (default)	A blank with a time delay is sent before the output string.
4	Prefix & Sync	A blank with a time delay and the sync sequence UU~?~? is sent before the output string.

G-E-A-B-D Prefix holdback

`generic-rs-485-protocol-prefix-holdback`

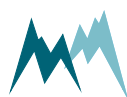

The hold-back time defines the time delay between the prefix and the data string.

Value range	Default	Units
0...5'000	300	ms

G-E-A-C Port

G-E-A-C-A Baud rate

`generic-rs-485-port-baud-rate`

The following transmission rates in bps (baud) can be selected:

ID	Option	Description
1	1'200	-
2	2'400	-
3	4'800	-
4	9'600 (default for sensors and data logger inputs)	-
5	19'200 (default if used with radio communication)	-
6	38'400	-
7	57'600	-
8	115'200 (default for data loggers)	-

G-E-A-C-B Parity, stop bits

`generic-rs-485-port-parity-stop-bits`

The following combinations of parity and stop bits can be selected:

ID	Option	Description
1	No par, 1 stop (default)	No parity and 1 stop bit
2	No par, 2 stop	No parity and 2 stop bits
3	Even par, 1 stop	Even parity and 1 stop bit
4	Odd par, 1 stop	Odd parity and 1 stop bit

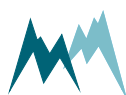

G-E-A-C-C Minimum response time`generic-rs-485-port-minimum-response-time`

This setting avoids failures of half-duplex interfaces. For this purpose the response to a command is delayed by the selected time. Additionally, the response is also kept temporally compact.

Value range	Default	Units
0...2'000	10	ms

G-E-A-C-D Transmitter warm-up time`generic-rs-485-port-transmitter-warm-up-time`

The transmitter warm-up time defines the time before data is sent.

Value range	Default	Units
0...2'000	10	ms

G-E-A-C-E Flow control`generic-rs-485-port-flow-control`

Flow control for the defined application.

ID	Option	Description
1	Off	no flow control
2	XOFF-XON blocking (default)	XOFF-XON flow control, especially adapted for half-duplex systems
4	DFM-RC	Flowcontrol for Sommer Messtechnik DFM point-to-point radios.
5	DFM-TM	Flowcontrol for Sommer Messtechnik DFM tiny-mesh radios.

G-E-A-C-F Sending window`generic-rs-485-port-sending-window`

If XON-XOFF flow control is activated data are transmitted in blocks with the defined length.

Value range	Default	Units
200...5'000	300	ms



G-E-A-C-G Receiving window

`generic-rs-485-port-receiving-window`

If XON-XOFF flow control is activated transmission of blocks is delayed by the specified time.

Value range	Default	Units
200...5'000	300	ms

G-E-A-C-H Transparency to RS485 A/B

`generic-rs-485-port-transparency-rs-485-2`

Only required in terminal mode. After activation, direct communication with a connected sensor is enabled, i.e. commands and their answers are exchanged over the RS485-2 interface of the MRL-IE. With this mode the settings of a connected digital sensor can be read or changed.

The transparency mode has some restrictions:

- Data logger polling is inactive.
- You can only access a connected sensor with ??? if no other sensor is connected to the RS-485 bus.
- If a sensor in the RS-485 bus pushes data, it will interfere with any parametrization effort unless it is switched off.

G-E-A-D Trigger

G-E-A-D-A Polling

`generic-rs-485-port-trig-polling`

Sets the polling of connected digital sensors.

ID	Setting	Description
1	Off (default)	Regular polling is inactive.
2	On	Regular polling is active. This settings allows the interface to switch into sleep mode between pollings.

G-E-A-D-B Timeout

`generic-rs-485-port-trig-timeout`

The time the MRL-IE is waiting until expected commands/answers are received via the RS485-2 interface.

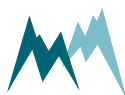

Value range	Default	Units
3 ... 250	60	s

G-E-A-D-C Sleep while timeout

`generic-rs-485-port-trig-sleep-timeout`

To reduce power consumption the MRL-IE can switch to a sleep mode between measurements.

ID	Setting	Description
1	Off (default)	MRL-IE remains activated between measurements, i.e. during Timeout
2	On	MRL-IE is inactive between initialization of measurement and reception of measurement data. The connected sensor must send a Prefix command to wake up the MRL-IE for data transmission.

G-E-A-D-D Polling delay

`generic-rs-485-polling-delay`

Time by which polling of multiple digital sensors is delayed. Used to poll sensors in sequence to avoid communication conflicts during subsequent measurement data transmission.

Value range	Default	Unit
0 ... 20	2	sec

G-E-B SDI-12 Master

G-E-B-A	Max. measurement duration	135
G-E-B-B	Sensor supply (always on)	136
G-E-B-C	Sensor search	136
G-E-B-D	Change sensor address	136
G-E-B-E	SDI-12 address	136
G-E-B-F	Transparency to SDI-12	136

G-E-B-A Max. measurement duration

`generic-sdi-12-max-measurement-duration`

The timeout for commands sent to SDI-12 devices connected to the MRL-IE. After the MRL-IE has received a response, it goes back into sleep mode. If a SDI-12 device does not respond within this time the MRL-IE returns a measurement error.

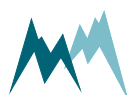

Value range	Default	Units
0...255	20	sec

G-E-B-B Sensor supply (always on)

`mrl-12v-sensor-supply-always-on`

Sets the 12V sensor supply.

ID	Setting	Description
1	Off (default)	The sensor supplies 12V / 14V and SW2 are off.
2	SW2	The sensor supply SW2 is active.
3	12V / 14V	The sensor supply 12V / 14V is active.
4	12V / 14V & SW2	Both sensor supplies 12V / 14V and SW2 are active.



NOTE If one of the listed sensor supplies has been selected, it also remains active during the sleep mode of the MRL-IE.

G-E-B-C Sensor search

`generic-sdi-12-sensor-search`

Searches for connected SDI-12 sensors and lists their identification and sensor address in the terminal window.

G-E-B-D Change sensor address

`generic-sdi-12-change-sensor-address`

Changes the SDI-12 address of a connected sensor.

G-E-B-E SDI-12 address

`generic-sdi-12-address`

The address is a unique identifier of the sensor within a SDI-12 bus system.

Value range	Default	Units
0...9, a...z, A...Z	0	-

G-E-B-F Transparency to SDI-12

`mrl-sdi-12-transparency`

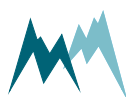

Enables direct communication with a connected device, i.e. commands and their answers are exchanged over the SDI-12 interface of the MRL-IE. Requires knowledge about SDI-12 communication.

G-E-C Analog inputs

G-E-C-A	AIN signal type	137
G-E-C-B	Warm-up time	137
G-E-C-C	ADC - conv. Rate	138
G-E-C-D	ADC filter	138
G-E-C-E	Sensor supply	138

G-E-C-A AIN signal type

`mrl-ain-signal-type`

Measurement type of analog input channels.

ID	Setting	Description
1	Voltage 2.5 V	Single ended voltage input 0 ... 2.5 V
2	Diff volt. 2.5 V	Differential voltage input 0 ... 2.5 V
3	Diff volt. 1.25 V	Differential voltage input 0 ... 1.25 V
4	Diff volt. 0.311 V	Differential voltage input 0 ... 0.311 V
5	Diff volt. 0.032 V	Differential voltage input 0 ... 0.032 V
6	R meas < 100k	Measures a resistance <100 kΩ
7	R meas < 3k	Measures a resistance <3 kΩ
8	R meas < 300	Measures a resistance <300 Ω
9	4...20 mA	Current input 4 ... 20 mA
10	PT1000	Measures the temperature of a PT1000 temperature sensor
11	NTC (2k2)	Measures the temperature of a 2k2 NTC-thermistor
12	AD592	Measures the temperature of an AD592 temperature sensor
13	PT100	Measures the temperature of a PT100 temperature sensor

G-E-C-B Warm-up time

`generic-warm-up-time`

The time between the power-supply is switched on and the first measurement.

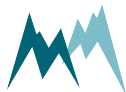

Value range	Default	Units
0...255	0	sec

G-E-C-C ADC - conv. Rate

mrl-adc-conversion-rate

The sampling rate of the analog inputs.

ID	Setting	Description
1	2 Hz	Sampling rate of 2 Hz
2	3 Hz	Sampling rate of 3 Hz
3	5 Hz	Sampling rate of 5 Hz
4	8 Hz	Sampling rate of 8 Hz
5	25 Hz	Sampling rate of 25 Hz
6	62 Hz (default)	Sampling rate of 62 Hz
7	125 Hz	Sampling rate of 125 Hz
8	250 Hz	Sampling rate of 250 Hz

G-E-C-D ADC filter

mrl-adc-filter

Filter for analog data acquisition.

ID	Setting	Description
1	Off (default)	Each analog channel is sampled once and no filter is applied.
2	Minimum of 3	Each analog channel is sampled three times per measurement cycle and the minimum value is returned.
3	Median of 3	Each analog channel is sampled three times per measurement cycle and the median value is returned.
4	Mean of 3	Each analog channel is sampled three times per measurement cycle and the mean value is returned.

G-E-C-E Sensor supply

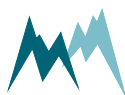

G-E-C-E-A SW2`mrl-sensor-supply-sw2`

Sets the switched sensor supply (terminal Supply 3).

ID	Setting	Description
1	off (default)	Switched supply is inactive.
2	Switched	Switched supply is active, i.e. power is supplied only during warm-up and measurement.
3	Always on	Switched supply is always on.

G-E-C-E-B 12 V / 14 V`mrl-sensor-supply-12v-14v`

Sets the 12/14 V sensor supply (terminal Supply 2).

ID	Setting	Description
1	off (default)	12/14 V sensor supply is inactive
2	Switched	12/14 V sensor supply is active
3	Always on	12/14 V sensor supply is always on

G-E-C-E-C 5V`mrl-5v-sensor-supply`

Sets the 5V analog sensor supply.

ID	Setting	Description
1	Off (default)	5V sensor supply is inactive
2	Switched	5V sensor supply is active during analog measurements
3	Always on	5V sensor supply is always on

G-E-C-E-D 2.5 V`mrl-2.5v-sensor-supply`

Sets the 2.5 V sensor supply.

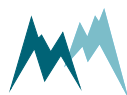

ID	Setting	Description
1	Off (default)	The 2.5V sensor supply is inactive
2	Switched	The 2.5V sensor supply is active during analog measurements
3	Always on	2.5V sensor supply is always on

G-E-C-E-E External sensor supply

mrl-external-sensor-supply

Switch to select between internal and external power supply. This setting enables optimized power management by timely switching the links to the internal shunt resistors. In general, this setting must be *on* if a sensor is not powered by the MRL-IE.



ATTENTION If a connected analog sensor is operated with an external power supply, this parameter must be set to *on*.

ID	Setting	Description
1	Used (default)	At least one analog sensor is powered by an external source.
2	Not used	All connected analog sensors are powered internally

G-E-D Additional meas. settings

G-E-D-A	12V / 14V output voltage	140
G-E-D-B	Wind speed measurement duration	141
G-E-D-C	Sum, reset time	141
G-E-D-D	Conversion table A	141
G-E-D-E	Conversion table B	141

G-E-D-A 12V / 14V output voltage

mrl-12v-or-14v

Selects 12 or 14 V sensor supply (terminal Supply 2).

ID	Setting	Description
1	12 Volt (default)	12V / 14V sensor supply is set to 12 V
2	14 Volt	12V / 14V sensor supply is set to 14 V

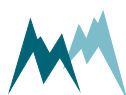

G-E-D-B Wind speed measurement duration

mrl-wind-speed-measurement-duration

The time for measuring the wind speed with a connected anemometer. With longer measurement times lower velocities can be accurately determined. However, longer measurement times also increase power consumption.

Value range	Default	Unit
500...2000	1000	ms

G-E-D-C Sum, reset time

mrl-sum-reset-time

Time at which the sums of summed variables defined in [Measurement table](#) are reset to zero.

Value range	Default	Unit
00:00:00 ... 23:59:59	07:00:00	-

G-E-D-D Conversion table A

mrl-A-table

X-Y look-up table with up to 32 data-pairs. For a variable in [Measurement table](#) with the function *VA* in *S-ADD* the referenced variable of *S-NUM* is passed as *X* to the look-up table and the corresponding interpolated value of *Y* is returned. Up to 6 decimal places are supported.

G-E-D-E Conversion table B

mrl-B-table

X-Y look-up table with up to 32 data-pairs. For a variable in [Measurement table](#) with the function *VB* in *S-ADD* the referenced variable of *S-NUM* is passed as *X* to the look-up table and the corresponding interpolated value of *Y* is returned. Up to 6 decimal places are supported.

G-F Analog outputs (MRL-IEa only)

G-F-A	Overview (MRL-IEa)	141
G-F-B	Simulate current output	142

G-F-A Overview (MRL-IEa)

mrl-analog-output-overview



Defines the behavior and scaling of the analog outputs. The available options are described in the table below.

Identifier	The name of the analog output, <i>IOUT 1 ... IOUT 4</i>
Output status	<p>The behavior of the analog output:</p> <p><i>off</i> Analog output is inactive</p> <p><i>just during TRIG</i> Analog output is only active when TRIG input is high</p> <p><i>always on</i> Analog output is always active</p>
Measurement channel nr.	The index of the variable in Measurement table for which the analog output is generated.
4 mA value	The value of the variable specified in Measurement table that corresponds to 4 mA.
4.20 mA span	The value range of the variable specified in Measurement table that corresponds to the 4 ... 20 mA span.



NOTE The analog value corresponds to the **Function** specified in [Measurement table](#), i.e., if **Function** is set to *actual*, the measurement value is returned, if **Function** is set to one of the aggregation options, the aggregated value is returned.



NOTE Measurement values as well as auxiliary values can be converted to analog outputs.

G-F-B Simulate current output

generic-analog-out-simulate-current

With this function the analog outputs can be simulated. Upon submission of a current value between 4 and 20 mA the corresponding values of the selected variable are displayed. The selected current is also applied to the active analog outputs and can be read with a connected data logger or multimeter. By pressing Return/Enter again the simulation stops.

G-G Digital outputs (MRL-IEa only)

mrl-digital-output-settings

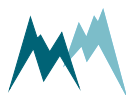

Defines the type of the digital outputs. The available options are described in the table below.

Identifier	The name of the digital output, <i>DIG-OUT 1 ... DIG-OUT 2</i>
Output status	<p>The type of the digital output:</p> <ul style="list-style-type: none"> <i>off</i> The digital output is inactive. <i>Limit monitor</i> If the Limit value of the variable specified in Channel allocation is violated, the digital output is set to high. <i>Impulse output</i> The value of the variable specified in Channel allocation is translated to an equivalent number of impulses and applied to the digital output. A comma is ignored. For example, a value of <i>12.6</i> returns <i>126</i> impulses.
Measurement channel nr.	The variable listed in Measurement table whose value is monitored. This can be a regular or an auxiliary variable.
Limit type	<ul style="list-style-type: none"> <i>above</i> If the recorded value exceeds the Limit value the digital output is activated. <i>below</i> If the recorded value falls below the Limit value the digital output is activated.
Limit value	The limit value of the variable specified in Channel allocation .
Hysteresis	<p>Setting a hysteresis value suppresses multiple violations if the measurement value closely fluctuates around the threshold. After a violation the output state is preserved until the measured value exceeds or falls below the specified hysteresis value. The hysteresis is an absolute value and is added with the correct sign to the threshold. The figure below illustrates an example.</p> <p>The graph illustrates the effect of hysteresis on a digital output (DOUT). The vertical axis is labeled 'Value' and the horizontal axis is 'Time'. A solid red horizontal line represents the 'Limit'. A dashed red horizontal line below it represents the 'Hysteresis' level. The output state is shown as a step function: 'DOUT high' when the measured value is above the limit, and 'DOUT low' when it is below the hysteresis level. The graph shows several data points (blue dots) fluctuating around the limit. When the value crosses the limit from below, the output goes high. When it crosses the hysteresis level from above, the output goes low. This prevents multiple violations when the value fluctuates near the limit.</p>



Quantity per impuls	<p>The quantity that represents one impuls.</p> <p>0.01 */imp 0.1 */imp 1 */imp * ... unit of variable referenced in Measurement channel nr. 10 */imp 100 */imp 1000 */imp</p>
Min. impulse width	<p>The minimum duration of the voltage impulse: <i>500 ms, 100 ms, 30 ms</i></p>
Output	<p><i>measurement value</i> The measured value is returned.</p> <p><i>statistic value</i> The aggregated statistic value is returned.</p>
Test	<p>Function to test the digital output.</p>

H Region format

H-A	Language/Sprache	144
H-B	Decimal character	144

H-A Language/Sprache

`generic-language`

The menu language.

ID	Option	Description
1	German/Deutsch	German language
2	English/Englisch (default)	English language

H-B Decimal character

`generic-decimals-character`

The character used as decimal separator in the values of the settings, in serial data strings and in .csv files.

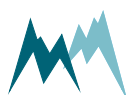

ID	Option	Description
1	Comma	-
2	Dot (default)	-

I Special functions

I-A	Device status	145
I-B	Last date sync.	145
I-C	Last time sync.	145
I-D	View setup	145
I-E	Continuous meas. mode (temp).	145
I-F	Set factory default	146
I-G	Temp. load factory default	146
I-H	Relaunch program	146
I-I	Replace program	146

I-A Device status

`generic-special-functions-device-status`

Displays information about the device and the software version.

I-B Last date sync.

`mrl-sync-date-last`

The date at which the MRL-IE has been last synchronized; read only.

I-C Last time sync.

`mrl-sync-time-last`

The time at which the MRL-IE has been last synchronized; read only.

I-D View setup

`generic-special-functions-view-setup`

All parameters of the MRL-IE are listed in the terminal window.

I-E Continuous meas. mode (temp).

`generic-special-functions-continuous-meas-mode`



Inactive in the Commander menu. This feature can be triggered in the Commander under the **Measurement (F3)** tab with the command **Start polling measurements** and then **Start polling WITH measurements**. When active, measurements are performed continuously, ignoring the specified measurement interval.

I-F Set factory default

`generic-special-functions-set-factory-default`

All parameters are reset to factory defaults. Only available in terminal-mode.

I-G Temp. load factory default

`generic-special-functions-temp-load-factory-default`

Loads factory default values temporarily. Only available in terminal mode.

I-H Relaunch program

`generic-special-functions-relaunch-program`

The device is restarted. Powering the sensor off and on again is equivalent.

I-I Replace program

`generic-special-functions-replace-program`

The sensor is set into a "Boot Loader" mode for three minutes to upload new software remotely. Not required for local firmware update.

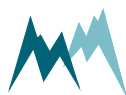

Appendix A Troubleshooting

1.1	Configuration errors	147
1.1.1	Conflict messages	147
1.1.2	Parameter conflicts	148
1.1.3	Setup conflicts	149
A.2	Devices	150
A.2.1	The MRL-IE is not responding or returns unreadable characters ..	150
A.2.2	The MRL-IE reboots repeatedly	150
A.3	Measurement data	151
A.3.1	Measurement data are not updated	151
A.4	Firmware & software	151
A.4.1	Commander loads wrong setup	151
A.4.2	Firmware update via RS-485 is aborted	151
A.5	SDI-12	152
A.5.1	The MRL-IE is not detected by a SDI-12 master device	152
A.5.2	Data logger receives no SDI-12 data	152
A.6	Modbus	153
A.6.1	Modbus function 04 returns obscure measurement values	153
A.7	Tips & tricks	153
A.7.1	Send multiple SDI-12 requests	153

1.1 Configuration errors

1.1.1 Conflict messages

During configuration with the Commander software, the MRL-IE may return conflict messages after one or more parameters have been changed and uploaded to the device. An example is shown in [Figure 1](#).

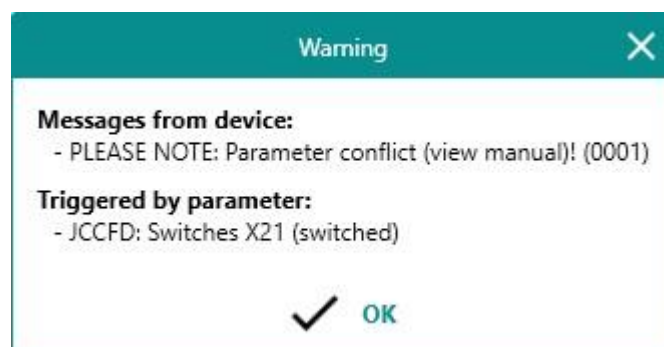
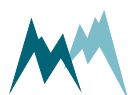

Figure 1 Example of a conflict message

The pop-up window lists the parameters and their indices which have triggered the warning. See [Parameter conflicts](#) for details.





ATTENTION If a conflict occurs, invalid settings are replaced automatically with valid values. Verify the values of the conflicting parameters and adapt them if needed!

1.1.2 Parameter conflicts

A parameter conflict message as listed below is returned if the value of a parameter conflicts with another parameter setting.

Changed parameter	Comment
Measurement channel nr. in Overview (MRL-IEa)	If the value of Measurement channel nr. is higher than Measurements, max. number, Measurement channel nr. is set to Measurements, max. number.
Measurement channel nr. in Digital outputs (MRL-IEa only)	If the value of Measurement channel nr. is higher than Measurements, max. number, Measurement channel nr. is set to Measurements, max. number.
Function in Measurement table	If Function in Measurement table is changed to an option other than <i>actual</i> and Measurement trigger is not <i>interval</i> , Measurement trigger is switched to <i>interval</i> .
Measurement trigger	If Function in Measurement table is not <i>actual</i> and Measurement trigger is changed to an option other than <i>interval</i> , Function is switched to <i>actual</i>
Measurement output in menu RS485-1 (COM)	If Measurement output is changed to <i>statistic push</i> and Measurement trigger is not <i>interval</i> , Measurement output is switched to <i>measured values push</i> .
Measurement trigger	If Measurement output in menu RS485-1 (COM) is <i>statistic push</i> and Measurement trigger is changed to an option other than <i>interval</i> , Measurement output is switched to <i>measured values push</i> .

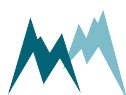

Changed parameter	Comment
Measurement output	If Measurement output is changed to <i>statistic push</i> and Measurement trigger is not <i>interval</i> , Measurement output is switched to <i>measured values push</i> .
Measurement trigger	Measurement output is <i>statistic push</i> and Measurement trigger is changed to an option other than <i>interval</i> , Measurement output in menu SBP sensor feedback is switched to <i>measured values push</i> .
Output in menu Digital outputs (MRL-IEa only)	If Output is changed to <i>statistic value</i> and Measurement trigger is not <i>interval</i> , Output is switched to <i>measurement value</i> .

Table 1 Parameter conflict messages

1.1.3 Setup conflicts

A setup conflict message as listed below is returned if a modified setup with conflicting parameters is loaded onto the MRL-IE.

Conflict code	Parameter	Comment
0001	Measurement Interval	If the interval is shorter than the sum of all individual measurement times, it is set to this sum. This internally calculated sum depends on the number and type of measurements, and the settings of <i>Warm-up time</i> , <i>ADC - conv. Rate</i> , <i>ADC filter</i> and others.
0002	Measurement output	If this parameter is set to <i>MODBUS</i> , <i>Measurement output</i> is set to <i>just per command</i> (Modbus can only poll data).

Table 2 Setup conflict messages

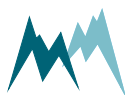

A.2 Devices

A.2.1 The MRL-IE is not responding or returns unreadable characters

Reason	Solution
The power supply is not connected or turned off.	Check if the power supply is connected and on.
The polarity of connected power supply wires is wrong.	Check the polarity of connected wires.
The power supply does not provide enough current.	Use a power supply that provides more current than listed in the Specifications .
The power supply voltage is out of range.	Adjust the power supply to match the specified voltage range.
A pin of the connector plug is bent or broken.	Verify that all connector pins are straight.
The COM-port has not been assigned correctly to the USB converter.	<ol style="list-style-type: none"> 1. Make sure to use a Sommer Messtechnik USB converter. Third party converters are not supported. 2. Check the COM-port number using Windows Device Manager. 3. Plug in the USB converter first, then start Commander.
The USB converter is faulty.	Replace the USB converter.
The USB port on your PC is not working.	Use another USB port.
The driver of the USB converter was incorrectly installed	Reinstall the driver of the USB converter.

A.2.2 The MRL-IE reboots repeatedly

Reason	Solution
The power supply has not enough current to start the MRL-IE.	Verify that the power supply provides enough current. A MRL-IE consumes up to 140 mA @ 12 V. If required, power the MRL-IE by an additional or alternative supply.

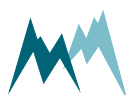

A.3 Measurement data

A.3.1 Measurement data are not updated

The device is connected to the Commander, but the data are not updated.

Cause	Solution
The MRL-IE triggers measurements (Polling is <i>On</i>) and triggers data (command <i>TD</i> added in <i>S-ADD</i> in Measurement table) of a sensor.	If the MRL-IE triggers measurements, remove the <i>TD</i> command and set the sensor to push data after measurements. See also Trigger measurements of a Sommer RS-485 device and Reading data from a Sommer RS-485 device .

A.4 Firmware & software

A.4.1 Commander loads wrong setup

If the setup is reloaded from the device the Commander seems to display an old version.

Cause	Solution
The device has been connected to the same PC before and several different setup files have been loaded.	<ul style="list-style-type: none"> • In the Communication section of the Commander, select Mode Connection and click on the trash can icon on the right edge. Then, reload the setup from the device. • Delete the setup files of the device that have been downloaded by Commander to the folder C:\Users\Public\Documents\Sommer\Setup. The respective files can be identified by the serial number in the file name and the file date.

A.4.2 Firmware update via RS-485 is aborted

Reason	Solution
USB to RS-485 converter cable is damaged or can only operate on 9600 baud.	Replace USB to RS-485 converter cable. The programmer requires 57600 baud.



A.5 SDI-12

A.5.1 The MRL-IE is not detected by a SDI-12 master device

Reason	Solution
The MRL-IE and the SDI-12 master have different grounds.	Verify that the MRL-IE and the SDI-12 master are connected by a ground (GND) wire.

A.5.2 Data logger receives no SDI-12 data

Reason	Solution
The Measurement trigger of a connected Sommer Messtechnik sensor is not set to <i>SDI-12/RS-485</i> .	Set the Measurement trigger of the sensor to <i>SDI-12/RS-485</i> .
Multiple sensors are connected to the data logger and two or more sensors have the same SDI-12 address.	If multiple sensors are connected to the same data logger, each sensor must be assigned a unique SDI-12 address.
The setting Max. measurement duration is too short. If the measurements of multiple SDI-12 sensors are triggered with the <i>M!</i> command, Max. measurement duration must be at least the sum of the measurement duration of these sensors. E.g., if sensor 1 has a measurement duration of 65 s and sensor 2 of 30 s, set Max. measurement duration to 100 s (95 s plus some margin).	Check the measurement duration of each sensor and set Max. measurement duration long enough.
Some third-party sensors may not issue a service request when they have completed a measurement.	If a sensor does not issue a service request after a measurement, a <i>C!</i> command instead of a <i>M!</i> command must be sent to start a measurement. Otherwise the data logger runs into a timeout or is waiting indefinitely for a service request.
The timing of the data logger between triggering a measurement and data request may be too tight.	Verify that the timing between triggering and data request is sufficient. Upon a measurement request, e.g. by an <i>M!</i> command, the sensor returns the required measurement duration.

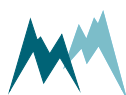

A.6 Modbus

A.6.1 Modbus function 04 returns obscure measurement values

Reason	Solution
Sensor does not run in its own measurement interval, i.e., MeasurementSet Mt trigger is not set to <i>Interval</i> .	Set Measurement trigger of the sensor to <i>Interval</i> . A Modbus master can only read measurement data, it cannot trigger measurements.
A second Modbus master is present in the RS-485 bus.	Make sure that only one Modbus master is communicating with the Modbus slaves.
The signal wires between the Modbus master and the slaves are long and/or the ground potentials of the devices are different.	<ul style="list-style-type: none"> ● Connect the grounds of the devices with an additional wire. ● Reduce the cable length.
Endianness of the Modbus polling unit is swapped. Generally, test values and measurement values are set to big endian. Older firmware versions may return measurement values as little endian.	If the device runs on an older firmware, convert the measurement values to float with little endian.

A.7 Tips & tricks

A.7.1	Send multiple SDI-12 requests	153
-------	-------------------------------------	-----

A.7.1 Send multiple SDI-12 requests

Use

Some serial sensors provide a long list of measurement data that need to be requested by multiple SDI-12 commands, i.e., *M1!*, *M2!*, *M3!*,...

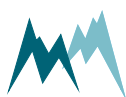

Implementation

Multiple SDI-12 requests are implemented by adding *_M1*, *_M2*, *_M3*, etc. to the *S-ADD* field of the measurement table. The corresponding *D!* commands are sent automatically. by the MRL-IE.



NOTE The *MO!* command is run by default and does not need to be added. Hence, for empty *S-ADD* fields *_M0* is assumed.

The same principle can be applied to the *R!* and *C!* commands.

F Measurements, table												
	Function	Identifier	Unit	Decimals	Scale	Offset			S-TYP	S-NUM	S-MEA	S-ADD
01	actual	Air Temperature	°C	as S		0	Adjustment	Test	SDI2	0	1	_M1
02	actual	Rel. Humidity	%	as S		0	Adjustment	Test	SDI2	0	2	_M1
03	actual	Dewpoint	°C	as S		0	Adjustment	Test	SDI2	0	3	_M1
04	actual	Pressure	hPa	as S		0	Adjustment	Test	SDI2	0	4	_M1
05	actual	Rel. Wind Speed	m/s	as S		0	Adjustment	Test	SDI2	0	2	
06	actual	Rel. Wind Dir.	°	as S		0	Adjustment	Test	SDI2	0	1	
07	actual	Corr. Wind Dir.	°	as S		0	Adjustment	Test	SDI2	0	3	
08	actual	Avg. Wind Speed	m/s	as S		0	Adjustment	Test	SDI2	0	2	_M9
09	actual	Avg. Wind Dir.	°	as S		0	Adjustment	Test	SDI2	0	1	_M9
10	actual	Wind Gust Speed	m/s	as S		0	Adjustment	Test	SDI2	0	4	_M9
11	actual	Wind Gust Dir.	°	as S		0	Adjustment	Test	SDI2	0	3	_M9
12	actual	Status Sensor	-	as S		0	Adjustment	Test	SDI2	0	5	_M1
13	actual	Supply V	V	2	1	0	Adjustment	Test	SYS		+Sup V	
14	actual	Sun Azimuth	°	as S		0	Adjustment	Test	SDI2	0	4	_M7
15	actual	Sun Elevation	°	as S		0	Adjustment	Test	SDI2	0	5	_M7
16	actual	Sunrise	h:m	as S		0	Adjustment	Test	SDI2	0	1	_M7
17	actual	Solar Noon	h:m	as S		0	Adjustment	Test	SDI2	0	2	_M7
18	actual	Sunset	h:m	as S		0	Adjustment	Test	SDI2	0	3	_M7
19	actual	Twilight Civil	h:m	as S		0	Adjustment	Test	SDI2	0	6	_M7
20	actual	X Tilt	°	as S		0	Adjustment	Test	SDI2	0	3	_M4
21	actual	Y Tilt	°	as S		0	Adjustment	Test	SDI2	0	4	_M4

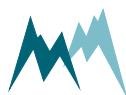

Appendix B Sensor connections

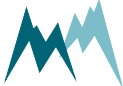

Appendix C CRC-16 array

CRC-16 array

```
1  crc16tab[] =
2  {
3  0x0000, 0x1021, 0x2042, 0x3063, 0x4084, 0x50A5, 0x60C6, 0x70E7,
4  0x8108, 0x9129, 0xA14A, 0xB16B, 0xC18C, 0xD1AD, 0xE1CE, 0xF1EF,
5  0x1231, 0x0210, 0x3273, 0x2252, 0x52B5, 0x4294, 0x72F7, 0x62D6,
6  0x9339, 0x8318, 0xB37B, 0xA35A, 0xD3BD, 0xC39C, 0xF3FF, 0xE3DE,
7  0x2462, 0x3443, 0x0420, 0x1401, 0x64E6, 0x74C7, 0x44A4, 0x5485,
8  0xA56A, 0xB54B, 0x8528, 0x9509, 0xE5EE, 0xF5CF, 0xC5AC, 0xD58D,
9  0x3653, 0x2672, 0x1611, 0x0630, 0x76D7, 0x66F6, 0x5695, 0x46B4,
10 0xB75B, 0xA77A, 0x9719, 0x8738, 0xF7DF, 0xE7FE, 0xD79D, 0xC7BC,
11 0x48C4, 0x58E5, 0x6886, 0x78A7, 0x0840, 0x1861, 0x2802, 0x3823,
12 0xC9CC, 0xD9ED, 0xE98E, 0xF9AF, 0x8948, 0x9969, 0xA90A, 0xB92B,
13 0x5AF5, 0x4AD4, 0x7AB7, 0x6A96, 0x1A71, 0x0A50, 0x3A33, 0x2A12,
14 0xDBFD, 0xCBDC, 0xFBBF, 0xEB9E, 0x9B79, 0x8B58, 0xBB3B, 0xAB1A,
15 0x6CA6, 0x7C87, 0x4CE4, 0x5CC5, 0x2C22, 0x3C03, 0x0C60, 0x1C41,
16 0xEDAE, 0xFD8F, 0xCDEC, 0xDDCD, 0xAD2A, 0xBD0B, 0x8D68, 0x9D49,
17 0x7E97, 0x6EB6, 0x5ED5, 0x4EF4, 0x3E13, 0x2E32, 0x1E51, 0x0E70,
18 0xFF9F, 0xEFBE, 0xDFDD, 0xCFFC, 0xBF1B, 0xAF3A, 0x9F59, 0x8F78,
19 0x9188, 0x81A9, 0xB1CA, 0xA1EB, 0xD10C, 0xC12D, 0xF14E, 0xE16F,
20 0x1080, 0x00A1, 0x30C2, 0x20E3, 0x5004, 0x4025, 0x7046, 0x6067,
21 0x83B9, 0x9398, 0xA3FB, 0xB3DA, 0xC33D, 0xD31C, 0xE37F, 0xF35E,
22 0x02B1, 0x1290, 0x22F3, 0x32D2, 0x4235, 0x5214, 0x6277, 0x7256,
23 0xB5EA, 0xA5CB, 0x95A8, 0x8589, 0xF56E, 0xE54F, 0xD52C, 0xC50D,
24 0x34E2, 0x24C3, 0x14A0, 0x0481, 0x7466, 0x6447, 0x5424, 0x4405,
25 0xA7DB, 0xB7FA, 0x8799, 0x97B8, 0xE75F, 0xF77E, 0xC71D, 0xD73C,
26 0x26D3, 0x36F2, 0x0691, 0x16B0, 0x6657, 0x7676, 0x4615, 0x5634,
27 0xD94C, 0xC96D, 0xF90E, 0xE92F, 0x99C8, 0x89E9, 0xB98A, 0xA9AB,
28 0x5844, 0x4865, 0x7806, 0x6827, 0x18C0, 0x08E1, 0x3882, 0x28A3,
29 0xCB7D, 0xDB5C, 0xEB3F, 0xFB1E, 0x8BF9, 0x9BD8, 0xABBB, 0xBB9A,
30 0x4A75, 0x5A54, 0x6A37, 0x7A16, 0x0AF1, 0x1AD0, 0x2AB3, 0x3A92,
31 0xFD2E, 0xED0F, 0xDD6C, 0xCD4D, 0xBDAA, 0xAD8B, 0x9DE8, 0x8DC9,
32 0x7C26, 0x6C07, 0x5C64, 0x4C45, 0x3CA2, 0x2C83, 0x1CE0, 0x0CC1,
33 0xEF1F, 0xFF3E, 0xCF5D, 0xDF7C, 0xAF9B, 0xBFBA, 0x8FD9, 0x9FF8,
34 0x6E17, 0x7E36, 0x4E55, 0x5E74, 0x2E93, 0x3EB2, 0x0ED1, 0x1EF0
35 }
```

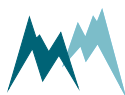

Glossary

I

IP-Call

A technology that provides communications services (voice, SMS, voice-messaging) over the Internet, rather than via the public telephone network.

M

Modbus

A serial communications protocol for connecting industrial electronic devices.

R

RS-485

A standard defining the signal transmission in serial communication systems.

S

SBP

Sommer Bus Protocol

SDI-12

Asynchronous serial communications protocol for intelligent sensors (Serial Digital Interface at 1200 baud)

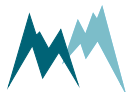

Index

