

SSG-2

Snow scale for SWE determination

Manual

Setup version 4.20 (Firmware 2.34)

14.02.2025



Sommer Messtechnik

All rights reserved.

The Copyrights for this manual are exclusively owned by

Sommer Messtechnik
6842 Koblach
Austria

This manual or parts of it may only be copied or passed on to third parties with written permission of Sommer Messtechnik. This applies to printed as well as digital issues of this manual.



Sommer Messtechnik
Strassenhäuser 27
6842 Koblach
Austria
www.sommer.at
E office@sommer.at
T +43 5523 55989
F +43 5523 55989-19

Validity

This manual applies to the Snow scale for SWE determination with the setup version 4.20, including all its subversions.

Created: 13 Nov, 2018

Last update: 14.02.2025



EU conformity



This product is in conformity with the following standards:

EMC	2014/30/EU	EN 301 489-1 V1.9.2
EMC	2014/30/EU	EN 61326-1:2013
		EN 55022:2010
LVD	2014/35/EU	EN 62311:2008
		EN 62368-1:2014
Machinery directive	2006/42/CE	
RoHS II	2011/65/EU	EN 50581:2012
RoHS III	2015/863/EU	
REACH	1907/2006/EU	

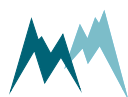

Safety information

Please read this manual carefully before installing or operating this equipment. Non-compliance with the instructions given in this manual can result in failure or damage of the equipment or may put people at risk by injuries through electrical or mechanic impact.

- Make sure that the personnel responsible for installation, configuration and maintenance is familiar with the applicable regulations and standards!
- Some parts of the device are heavy or long. For their handling contact your safety officer or consult applicable safety regulations for precautions and proper personal safety equipment.
- Do not perform any installations in bad weather conditions, e.g. thunderstorms.
- Prior to installation of equipment inform the owner of the measurement site or the authority responsible for it. Upon completion, secure the installation from trespassers.
- Maintenance and repair must be performed by trained personnel or an engineer of Sommer Messtechnik. Only replacement parts supplied by Sommer Messtechnik should be used for repairs.
- Make sure that NO power is connected to the equipment during installation and wiring!
- Only use a power supply that complies with the power rating specified for this equipment!
- Keep equipment dry during wiring and maintenance!
- If applicable, it is recommended to use accessories of Sommer Messtechnik with this equipment.

Disposal



After this device has reached the end of its lifetime, it must not be disposed of with household waste! Instead, dispose of the device by returning it to a designated collection point for the recycling of waste electrical and electronic equipment.



Feedback

Should you come across any error in this manual, or if you miss information to handle and operate the SSG-2 we are pleased to receive your feedback to office@sommer.at.

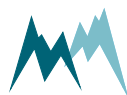

Content

- 1 What is the SSG-2? 11
- 2 Unpacking 12
- 3 Get started 13
 - 3.1 Connect the SSG-2 to your PC 13
 - 3.2 Configure the SSG-2 14
 - 3.3 Acquire measurements 14
- 4 How the SSG-2 works 15
- 5 Components 16
 - 5.1 Main 16
- 6 Specifications 17
- 7 Installation 19
 - 7.1 Site selection 19
 - 7.2 Things to consider for installation 20
 - 7.2.1 Power supply 20
 - 7.2.2 Signal cables 20
 - 7.3 Required tools and equipment 20
 - 7.4 Mounting 21
 - 7.4.1 General 21
 - 7.4.2 Preparations for rooftop mounting 22
 - 7.4.3 Assembly of supporting frame 22
 - 7.4.4 Assembly of the SSG-2 scale unit 25
 - 7.4.5 Attachment of marking rods 27
 - 7.4.6 Securing the SSG-2 on rooftops 29
 - 7.5 Wiring 30
 - 7.5.1 RS-485 wiring 30
 - 7.5.2 SDI-12 wiring 31
 - 7.5.3 How to wire analog outputs 31
 - 7.5.4 How to wire digital outputs 32
 - 7.6 Testing 33
 - 7.7 Start-up 33
- 8 Operation 34
 - 8.1 Connect device to PC 34
- 9 Maintenance 35
- 10 Calibration 36
 - 10.1 Set zero 36
 - 10.2 Set span, weight or Set span, SWE 36
- 11 Support software Commander 37



11.1	Software features	37
11.2	System requirements	37
11.3	Installation of Commander	37
11.4	Working with connections	42
11.4.1	Establish a connection with the Communication assistant	42
11.4.2	Establish a connection manually	43
11.4.3	Create a new connection	43
11.5	Working with stations	43
11.5.1	Create a station with the Communication assistant	43
11.5.2	Create a station manually	48
11.6	Working with measurements	49
11.6.1	Poll continuous measurements	49
11.6.2	Record measurements	50
11.7	Working with data	50
11.7.1	View live data	50
11.8	Working with setups	51
11.8.1	Download setup	51
11.8.2	Open a setup file	51
11.8.3	Edit setup	52
11.8.4	Upload new setup file	52
11.9	Update firmware	52
11.10	Change authorization	54
12	Configuration of the SSG-2	55
12.1	Software tools	55
12.2	Configuration with Commander support software	55
12.3	Configuration with a terminal program	58
12.4	Conflict messages	59
12.4.1	Setup conflicts	60
12.5	General settings	60
12.5.1	Measurement trigger	60
12.5.2	Language/Sprache	61
12.5.3	Decimal character	61
12.5.4	Units	61
12.5.5	Output protocol	61
12.5.6	Information	62
12.6	Measurement of snow water equivalent	62
12.6.1	SSG-2 filter options	62
13	Communication	63

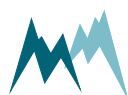

13.1	Communication protocols	63
13.2	Data output	63
13.2.1	Main values	63
13.2.2	Special values	64
13.2.3	Analysis values	64
13.2.4	Exception values	64
13.2.5	Error values	65
13.3	RS-485	66
13.3.1	What is RS-485?	66
13.3.2	What can I do with it?	66
13.3.3	Configuration	66
13.3.4	Data output options	68
13.3.5	Sommer Bus Protocol (SBP)	68
13.3.6	Standard protocol	71
13.3.7	RS-485 commands	74
13.3.8	Sommer Messtechnik CRC-16	76
13.4	SDI-12	78
13.4.1	What is SDI-12?	78
13.4.2	What can I do with it?	78
13.4.3	Configuration	78
13.4.4	Data structure	78
13.4.5	SDI-12 commands	79
13.5	Modbus	83
13.5.1	What is Modbus?	83
13.5.2	What can I do with it?	84
13.5.3	Wiring	84
13.5.4	Modbus configuration	84
13.5.5	Modbus commands and registers	90
13.5.6	Reactivate Sommer Bus Protocol	93
13.5.7	PLC integration	98
14	Analog output	99
14.1	What can I do with it?	99
14.2	Activation	99
14.3	Scaling	99
14.4	IOUT 1	100
14.5	Simulate current output	101
14.6	Digital output	101
14.6.1	What can I do with it?	101
14.6.2	Configuration	101

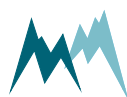

15	Parameter definitions	102
A	Measurement trigger	102
B	Measurement Interval	102
C	DIG-OUT limit monitor	103
C-A	Limit monitor	103
C-B	Limit type	103
C-C	Limit value	103
C-D	Hysteresis	104
D	Technics	104
D-A	Units	104
D-A-A	SWE	105
D-A-B	Weight	105
D-A-C	Temperature, unit	105
D-B	SBP device addressing	106
D-B-A	Device number	106
D-B-B	System key	106
D-C	RS-485 (COM)	106
D-C-A	Output protocol	107
D-C-A-A	Output protocol	107
D-C-A-B	Measurement output	107
D-C-A-C	Information	107
D-C-A-D	Wake-up sequence	108
D-C-A-E	Prefix holdback	108
D-C-A-F	MODBUS, set default	108
D-C-A-G	MODBUS, device address	109
D-C-B	Port	109
D-C-B-A	Baudrate	109
D-C-B-B	Parity, stop bits	110
D-C-B-C	Minimum response time	110
D-C-B-D	Transmitter warm-up time	110
D-C-B-E	Flow control	111
D-C-B-F	Sending window	111
D-C-B-G	Receiving window	111
D-D	SDI-12 Slave	111
D-D-A	SDI-12 address	112
D-D-B	SDI12 Information	112
D-E	Additional settings	112
D-E-A	Sleep mode	112
D-E-B	Sommer ID	113

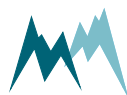

D-F	SSG calibration	113
	D-F-A SSG test	113
	D-F-B Set zero	113
	D-F-C Set span, weight	114
	D-F-D Set span, SWE	114
	D-F-E Edit zero & gain	114
D-G	SSG option, filter	114
	D-G-A Filter, no of values	114
	D-G-B Filter, type	115
	D-G-C SWE algorithm	115
	D-G-D Deactivation limits	115
	D-G-D-A Temperature limit	116
	D-G-D-B Weight limit	116
	D-G-D-C Load cell difference limit	116
D-H	Load cell analysis	116
D-I	Temperature	116
	D-I-A Ground temperature	117
	D-I-B Load cell temperature offset	117
	D-I-C Ground temperature offset	117
	D-I-D Test sensor temperatures	117
	D-I-E Adjust sensor temperatures	118
D-J	4-20 mA outputs	118
	D-J-A Output status	118
	D-J-B IOOUT1, SWE 4-20 mA span	118
	D-J-C IOOUT1, SWE 4 mA value	119
	D-J-D Simulate current output	119
E	Region format	119
	E-A Language/Sprache	119
	E-B Decimal character	120
F	Special functions	120
	F-A Device status	120
	F-B View setup	120
	F-C Continuous meas. mode (temp).	120
	F-D Set factory default	121
	F-E Temp. load factory default	121
	F-F Relaunch program	121
G	Measurement table	121
Appendix A Troubleshooting		122



A.1	Devices	122
A.1.1	The SSG-2 is not responding or returns unreadable characters	122
A.1.2	The SSG-2 reboots repeatedly	124
A.2	Measurement data	124
A.2.1	Measurement data are not updated	124
A.2.2	The SSG-2 reads zero weights	124
A.3	Firmware & software	124
A.3.1	Commander loads wrong setup	124
A.3.2	Firmware update via RS-485 is aborted	125
A.4	SDI-12	125
A.4.1	The SSG-2 is not detected by a SDI-12 master device	125
A.5	Analog output	126
A.5.1	The 4-20 mA output is wrong	126
Appendix B	CRC-16 array	127

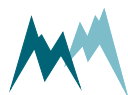

1 What is the SSG-2?

The SSG-2 snow scale is a precision device for measuring the snow water equivalent (SWE) of a snow pack. It has been developed for easy installation in the field and is equipped with specially designed aluminium panels which guarantee accurate measurements. These panels form a wide frame around the scale to minimize the effects of ice-bridging. The use of lightweight aluminium reduces thermal resistance, thus improving heat flow through the device. The SSG-2 is equipped with analog and digital ports, which allow integration into weather stations and other monitoring systems.

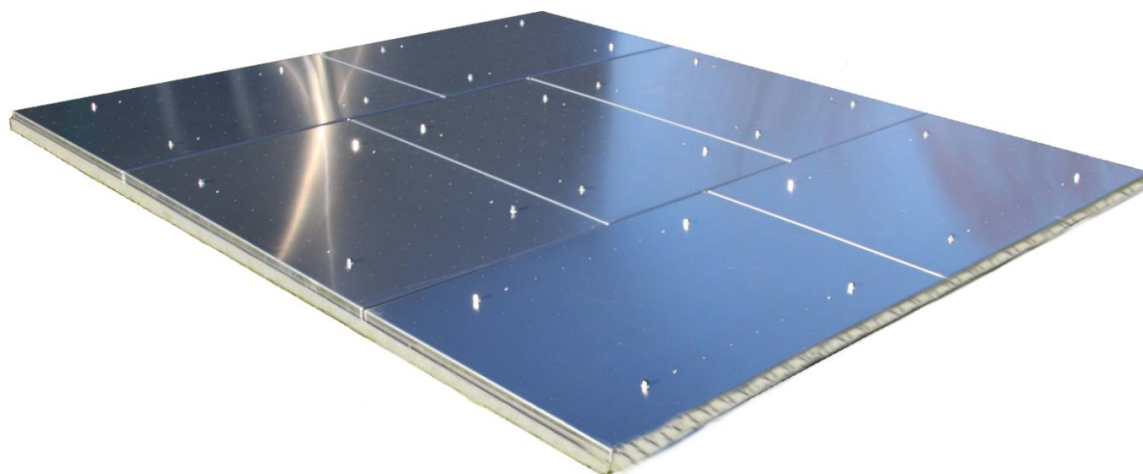

2 Unpacking

When unpacking your SSG-2 sensor box please make sure that the following items are present:

Description	Quantity
L-shaped aluminium profile	2
U-shaped aluminium profile	6
Aluminium panels	7
Marking rods	4
SSG-2 scale	1
Spacer bolt M8 Nut M8	24 24
Hex-head bolt M8x25 Washer M8	2 2
Hex-head bolt M6x16 Washer M6	1 2
Hex-head bolt M6x12 Washer M6	12 13
Hex-head bolt M5x12 Washer M5	8 9
Clips	8
Blanking plug	2
Flat wrench (10 and 13 mm)	1
Hex-spanner head M8	1
MAIN sensor cable SSG-2, 10 m	1
Manual and Commander Software on USB stick	1

In case of missing or damaged items please contact your Sommer Messtechnik sales partner.

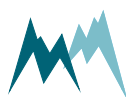

3 Get started

Follow the steps described below to set the basic configurations and to acquire the first measurement results.



NOTE Perform the first start-up in your lab or office before installing the equipment in the field!

3.1 Connect the SSG-2 to your PC

1. Install the Commander support software (see [Installation of Commander](#)).
2. Connect the yellow and gray wires of the sensor cable to the RS-485 to USB converter cable and plug it into your PC as illustrated in the figure below.
3. Connect a 9...28 VDC power supply to the SSG-2 as shown in the figure below.
4. Click on [Communication assistant](#) on the right-hand side of the Commander window and follow the instructions.
 - a. As [Type of connection](#) select [Serial connection](#)
 - b. As [Device type](#) select [Sensor \(9600 Bd\)](#)
 - c. Select [New connection](#) and select the COM port

During this procedure the communication assistant will search for connected devices. Upon successful completion, the new connection is added to the connections list (tab [Connections \(F8\)](#)).

5. In the [Communication](#) section at the right-hand side of the Commander window select Mode [Connection](#) and the previously created connection from the drop-down list.
6. Click [Connect](#) to establish a connection with the SSG-2. If the connection was successful a green icon is displayed at the top-right corner of the Commander window.
7. Select the tab [Parameters \(F2\)](#) and click [Download parameters from device](#) on the left side of the Commander window. The complete parameter list is transferred from the sensor to your PC and displayed in the [Parameter](#) window.

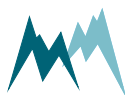
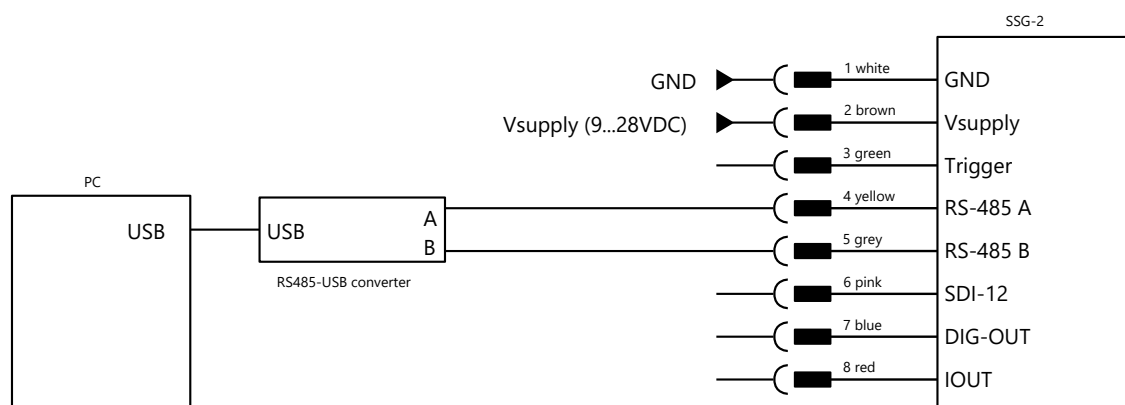

3.2 Configure the SSG-2

1. Select language, decimal character, units and decimal places (see [General settings](#))
2. Select the measurement trigger (see [Measurement trigger](#))
3. Define scope and structure of the data output (see [General settings](#))
4. Optional: Configure analog outputs (see [Analog output](#))
5. Send any modifications to the SSG-2 by clicking [Upload modified parameters to device](#).

3.3 Acquire measurements

1. Establish a connection to your device as described in [Working with connections](#).
2. Download the setup of your device as described in [Download setup](#).
3. Select the [Measurement \(F3\)](#) tab.
4. In the [Commands](#) section click [Start polling measurement](#).
5. Select the option [Polling with measurements](#). Now, the Commander will trigger measurements of the SSG-2 without any delays between measurements. The results are displayed [Measurement values](#) and plotted in the [Measurement data graph](#).
6. To finish polling mode click [Stop polling](#).

Commander 2.0.3.9

File | Tabs | Options | Tools | Extra | Help

Sommer GmbH | Connection: MRL, Serial: Port 1, 115200 Bd

Parameters (F2) | Measurement (F3) | Data (F4)

Information

Device: MRL
Protocol address: 0000
Parameter: Synchronized
Serial number: 0001
Setup version:
Software version:
Hardware version:
Time:

Command

Start and stop polling

Start polling measurements
Stop polling

Parameter commands

Download parameters from device
Download parameters from all devices

Measurement data commands

Clear measurement data
Save measurement data

Devices

MRL
0000
0001

Measurement values

ID	Name	Value	Unit
0	Self-check	0	
1	Level	40	mm
2	Velocity	1.003	m/s
3	Quality (SNR)	67.05	
4	Flow	5.143	m³/h
5	Flow sum		m³
6	Learned velocity	1.003	m/s
7	Learned flow	5.143	m³/h

Measurement data graph

Flow (m³/h)

5

— Self-check — Level [mm] — Velocity [m/s] — Quality (SNR) — Flow [m³/h] — Flow sum [m³] — Learned velocity [m/s] — Learned flow [m³/h]

Communication

Mode: Connection
Connection: Port
Devices: 0000 MRL, 0001
Logging:

Commands

Communication initiated
Connect
Disconnect

Terminal

Authorization: Normal

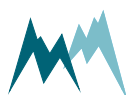

4 How the SSG-2 works

The scale of the SSG-2 is based on the principle of a load cell – a transducer which creates an electrical signal proportional to the force applied to the cell.

The SSG-2 consists of seven aluminium panels – 80 x 120 cm each – which are supported by an underlying frame. A scale with four load cells and the data acquisition device are located underneath the central panel. The other six panels are arranged around the central part to create a uniform surface without any ledges around the sensor that would create stress within the snowpack and result in erroneous readings. The aluminium panels are perforated to allow water to percolate to the ground. The used material also minimizes thermal differences between the sensor and the ground.

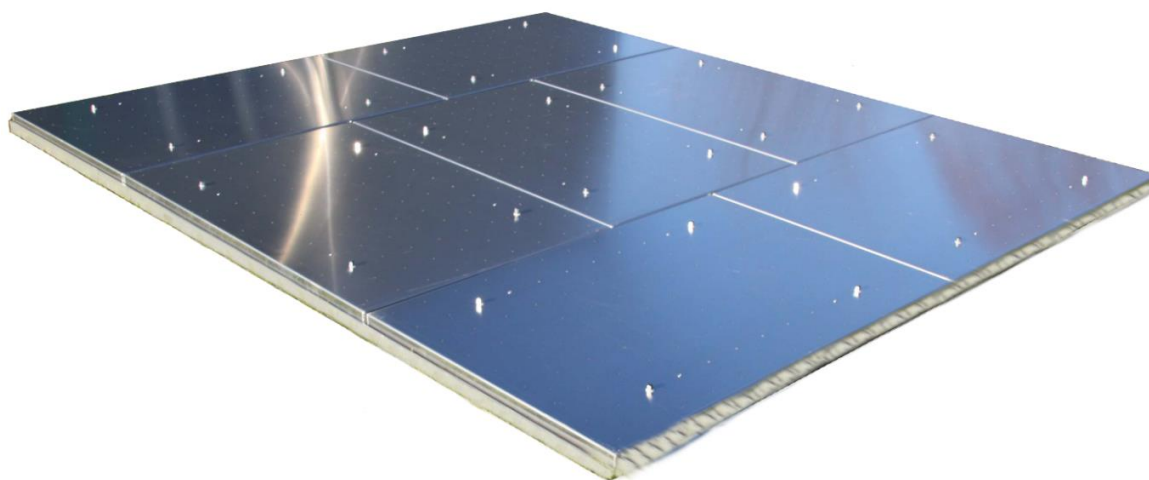

5 Components

5.1 Main

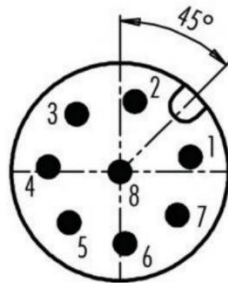

Figure 1 MAIN connector

	Pin	Color ¹	Function	Description
Power supply	1	white	GND	Ground
	2	brown	V _{Supply}	9...28 VDC
Trigger input	3	green	Trigger	low: 0...0.6 V high: 2...28 V
RS485 interface	4	yellow	RS485 A ²	RS485 (1200...115200 Baud)
	5	grey	RS485 B ²	
SDI-12 interface	6	pink	SDI-12	SDI-12 (1200 Baud)
Digital output	7	blue	DIG-OUT	max. 30 mA at V _{supply} – 0.5 V
Analog output	8	red	IOUT	SWE (4...20 mA)



NOTE The analog outputs and the trigger input are referenced to GND on pin 1.

¹Wire colour of the provided “Sommer” cable

²According to TI notation which differs from the standard EIA notation

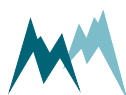

6 Specifications

Physical and environmental	
Power supply	9...28 VDC; Reverse voltage protection, overvoltage protection
Power consumption at 12 VDC	max. 50 mA active <1mA in sleep mode
Outputs	RS-485 SDI-12 Analog output 4...20 mA (14 bit, max. load 200 Ω) Digital output (low: 0V, high: V _{supply} , max. 30 mA at V _{supply} -0.5 V)
Operating temperature	-40...60 °C (-40...140 °F)
Storage temperature	-40...60 °C (-40...140 °F)
Environmental humidity	0...100 %rH
Protection rating	IP 68
Lightning protection	Integrated protection against indirect lightning with a discharge capacity of 6 kA Ppp
Housing material	Aluminium
Size L x W x H	2800 x 2400 x 103 mm (110.24 x 94.49 x 4.06 inch)
Surface area	6.72 m ²
Weight	110 kg (242.5 lb)
Max. inclination	5°

Snow water equivalent (SWE)	
Measurement range	0 ... 1.000 mm SWE 0 ... 2.000 mm SWE 0 ... 3.000 mm SWE
Accuracy	0...500 mmWC: ± 1 mmWC 500 mmWC ... Full scale: ± 0.2 % of reading
Resolution	0.1 mmWC (0.1 kg/m ²)
Measurement interval	10 s...3 h

Temperature measurement	
-------------------------	--

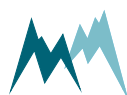

Temperature sensor	Pt1000
Measurement range	-40...60 °C (-40...140 °F)
Accuracy	0.2 °C (0.35 °F)
Resolution	0.01 °C (0.02 °F)



7 Installation

7.1 Site selection

The selection of a suitable site is crucial to gain SWE-data that are representative of the monitored area. Several aspects have to be considered when choosing a measurement site:

1. The measurement spot should be representative of the monitored area.
2. There should be no boulders, trees, fences or other objects in the vicinity of the measurement spot. If the SSG-2 is mounted on a roof, avoid building edges and facilities like heat exchangers. Any obstacle can cause snow drift and thus affect the measurement results.
3. The site must be safe from avalanches.

The SSG-2 has to be placed on a flat surface with a maximum inclination of 5°. It can be either mounted directly on the surface or lowered into the ground or upper rooftop layer to be level with the surrounding surface. Ideally, the upper soil layer of an area roughly 3 x 2.6 m is removed, a thin gravel layer is spread on the ground and the SSG-2 is installed on top to be level with the surrounding surface (see [Figure 2](#)).

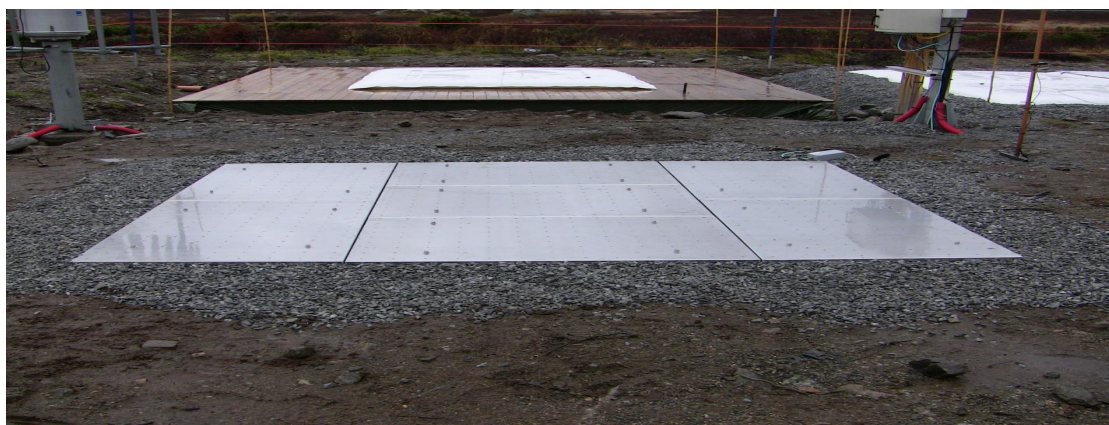

Figure 2 Installed SSG-2

Make sure the SSG-2 is not placed in a dip to prevent melt water submerging part of the device.

7.2 Things to consider for installation

7.2.1 Power supply

The SSG-2 is designed for extreme environmental conditions at remote sites and with no grid connection. The sensor switches automatically into standby-mode between measurements and thus consumes very little power which can be supplied by a 12V-solar-generator.

7.2.2 Signal cables

7.2.2.1 Maximum cable length

Please consider the maximum cable lengths for the applied transmission protocol:

Protocol	Max. cable length
SDI-12	~60 m (depending on wire cross section and number of sensors)
RS-485	~300 m

Table 1 Maximum cable lengths



NOTE Cable lengths longer than 60 m require a heavier gauge wire if the power supply drops below 11 V.

7.3 Required tools and equipment

Prepare the following tools and equipment to install the SSG-2:

Qty	Tool
1	Flat spanner 10 mm
1	Flat spanner 13 mm
1	Hex spanner with M8 head
1	4 mm screw driver
1	Measuring tape >4 m long
1	z-profiles (optional for rooftop-mounting)
several	Concrete slabs (optional for rooftop-mounting)

7.4 Mounting

7.4.1 General

The SSG-2 system consists of seven aluminium panels supported by a frame built of aluminium profiles. The SSG-2 scale is mounted under the central panel with the other six panels arranged around (see [Figure 3](#)). With this setup any edge effects due to different surfaces of the device and the surrounding ground are eliminated.



ATTENTION To avoid erroneous measurements, the SSG-2 must be installed on firm ground. If there is a risk of subsiding ground, reinforce the surface with logs or concrete slabs and install the SSG-2 on top of it.



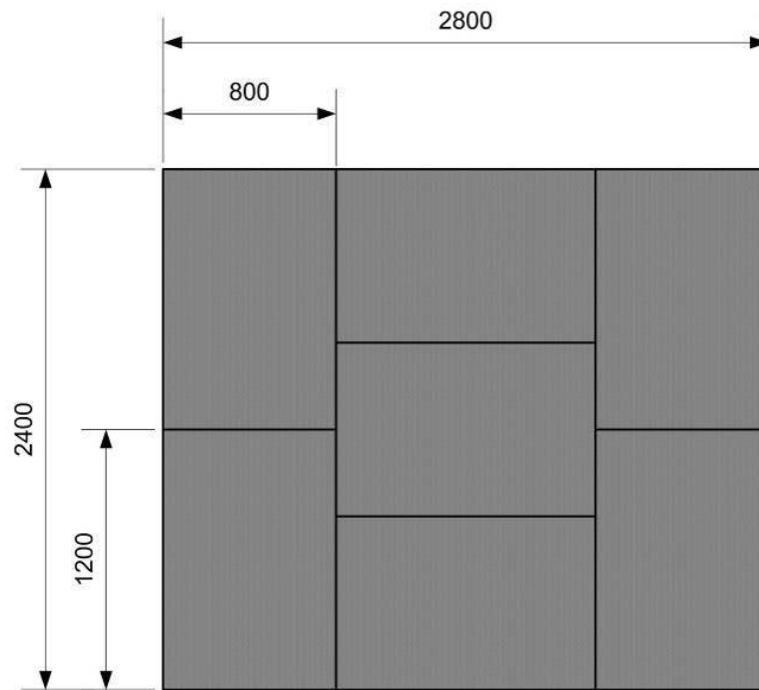

Figure 3 Arrangement of aluminium panels (dimensions in mm)

7.4.2 Preparations for rooftop mounting

If the SSG-2 is installed on a rooftop, gravel or any other loose layer needs to be removed at the spot of installation.

Before mounting the SSG-2, a rubber mat of the size 3600 x 4000 mm and about 10 mm thick should be laid out on the cleared spot.

7.4.3 Assembly of supporting frame

1. Screw in four spacer bolts into four U-profiles as illustrated in Figure 4. The longer threaded end must point upwards. Tighten the bolts only by hand!

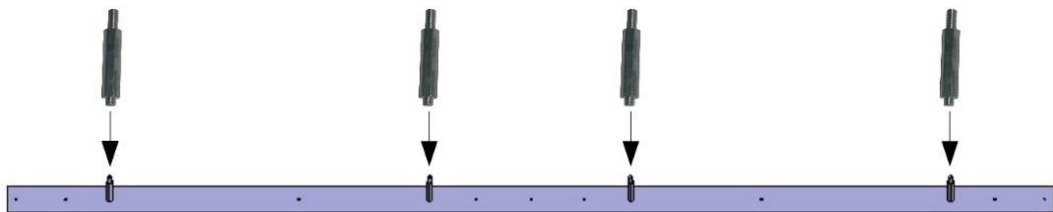

Figure 4 Assembly of U-profiles A

2. Screw in four spacer bolts into the remaining two U-profiles as illustrated in [Figure 5](#). The longer threaded end must point upwards. Tighten the bolts only by hand!

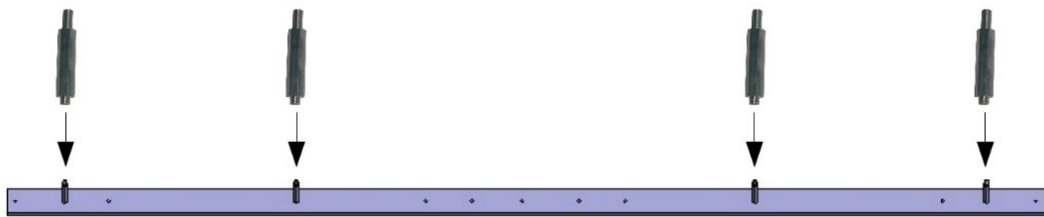

Figure 5 Assembly of U-profiles B

3. Assemble the U- and L-profiles with the provided M6x12 bolts and washers as illustrated in [Figure 6](#). Mount the L-profiles on top of the U-profiles as shown in [Figure 7](#). Do not tighten the screws yet!

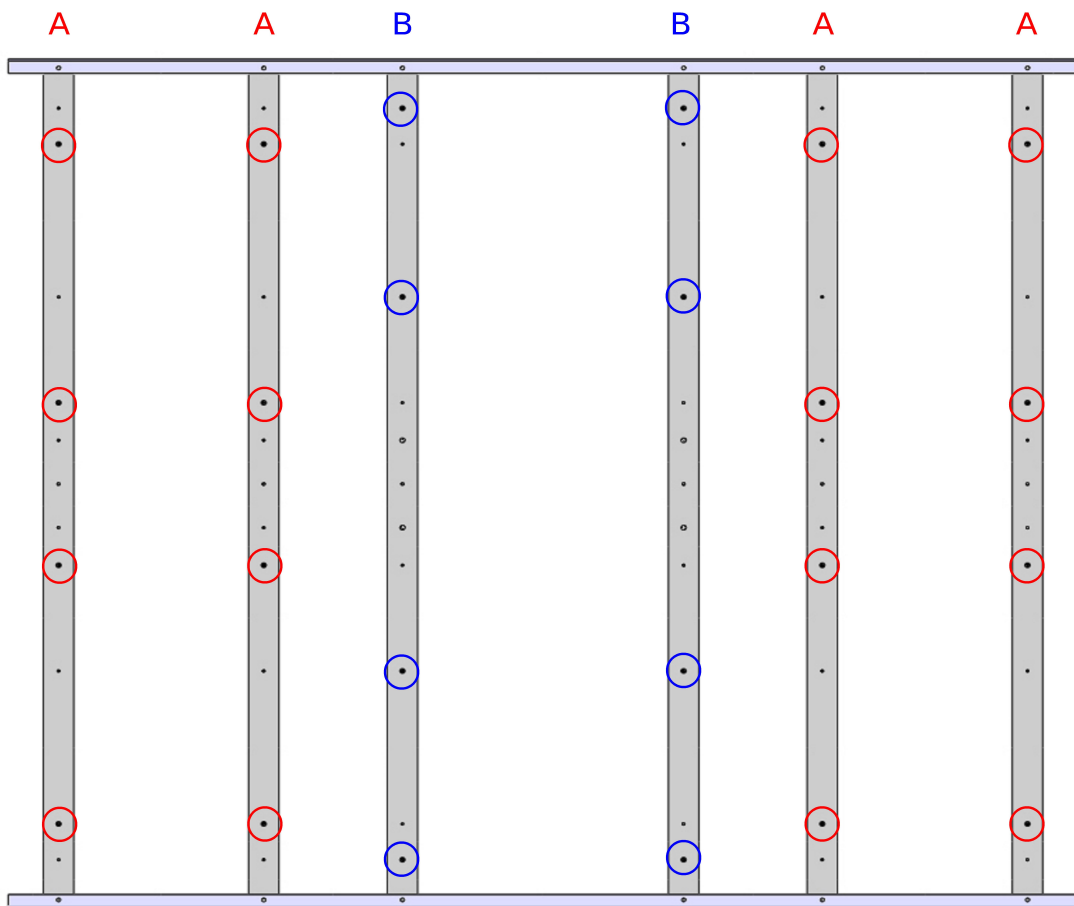
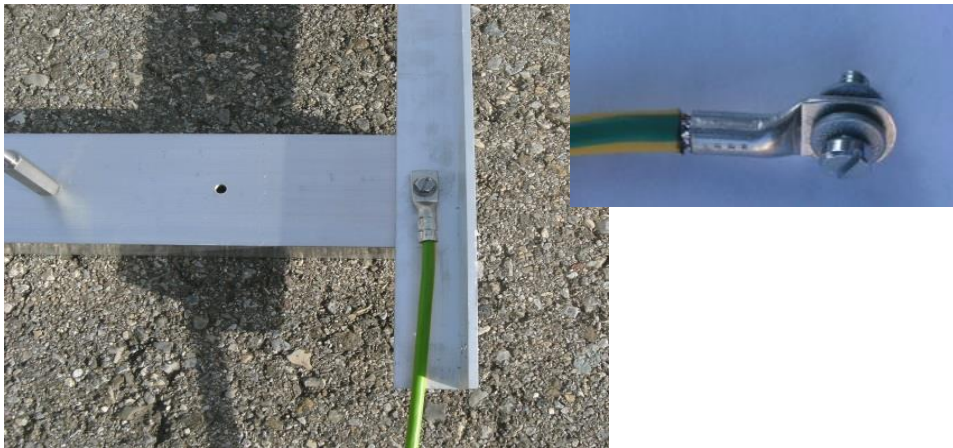

Figure 6 Assembly of supporting frame



Figure 7 Connection between U- and L-profile

4. Attach a 16-mm² grounding wire to one of the corners of the frame, using an M6x16 bolt and two washers (see).



Grounding wire

5. Measure the lengths of the diagonals of the frame and skew if necessary to the same lengths, 372 cm/146.46 in (see Figure 8).

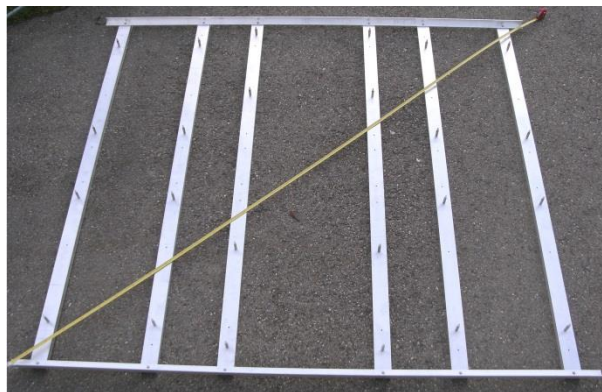

Figure 8 Check of the supporting frame

6. Tighten the screws.



ATTENTION Make sure that the U-profiles have firm contact to the ground! The weight loaded onto the SSG-2 is passed to the ground over these profiles.

7.4.4 Assembly of the SSG-2 scale unit

1. Place three aluminium panels on the frame as shown in Figure 9. Make sure that the spacer bolts slide into the holes of the panels. Leave the side open where the connector cable leads through.

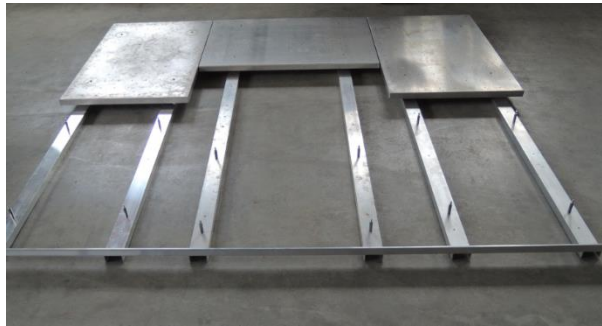
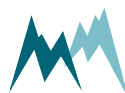

Figure 9 Attachment of aluminium panels



2. Fix the SSG-2 scale to the center of the frame with two M8x25 screws (see [Figure 10](#)) and cover the screw heads with blanking plugs.

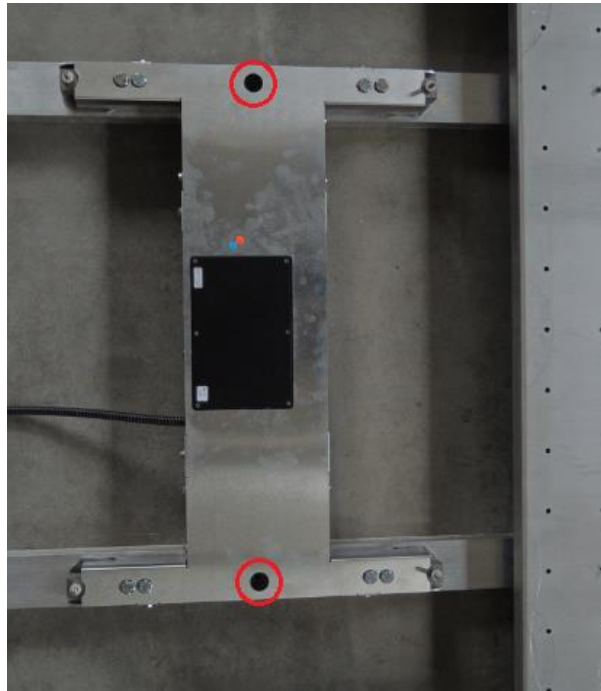

Figure 10 Placement of measurement device

3. Remove the head nuts from the four load cells on each corner of the SSG-2 scale (see [Figure 11](#)). Leave the plastic washers in place.



Figure 11 Load cell nut

4. Connect the MAIN cable and the optional ground-temperature sensor to the SSG-2 scale as illustrated in [Figure 12](#).

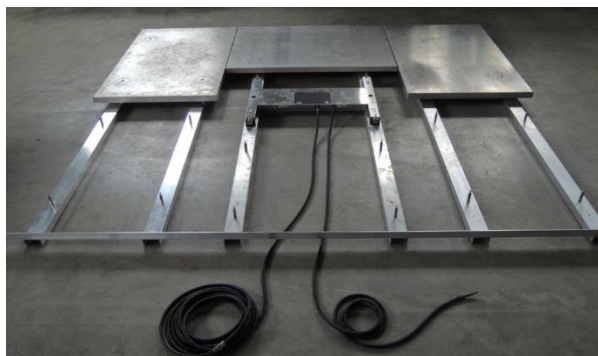

[Figure 12](#) Connection of MAIN and optional sensor cable

5. Place one of the aluminium panels on top of the measurement device and fix it with the previously removed head nuts. The plastic washers remain underneath the panel.



ATTENTION Tighten the head nuts on the center panel only by hand!



ATTENTION The bolts of the SSG-2 scale must not touch the borehole walls of the panel (see [Figure 13](#)).

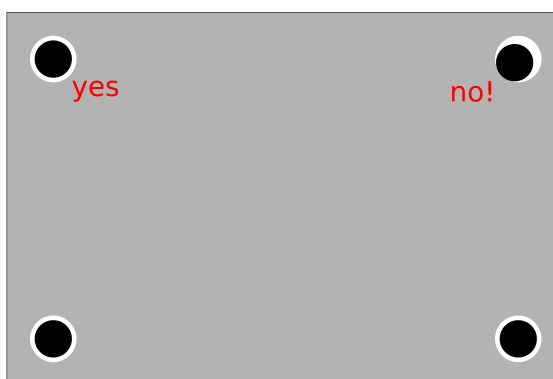

[Figure 13](#) Positioning of load cell bolts

6. Place the remaining aluminium panels on the frame.
7. Fix all aluminium panels with the provided M8 nuts and tighten them gently.

7.4.5 Attachment of marking rods

If the SSG-2 is mounted on a roof the enclosed marking rods should be attached as described below. By marking the edges of the SSG-2 they help to prevent damage when using snow blowers for

clearing the roof.

1. Slide each clip over a marking rod (a), gently bend it with your finger around the rod (b) and remove the clip again from the rod (c). Do not bend the clips without the marking rod!

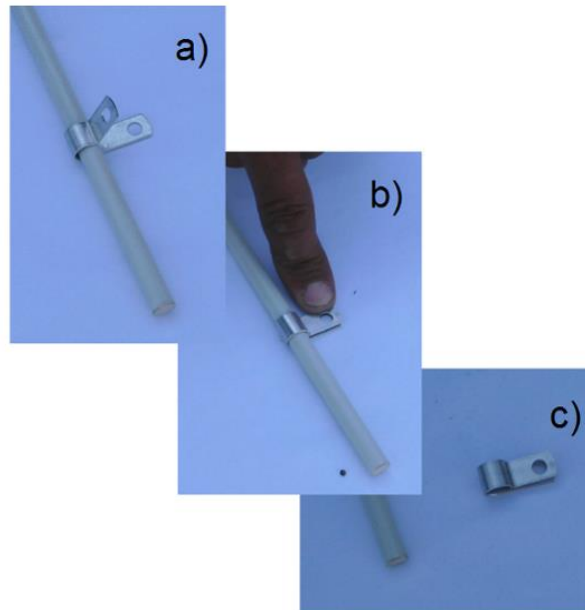

Figure 14 Preparation of marking rod bracket

2. Fix two clips to every corner of the supporting frame with the provided M5x12 screws (see Figure 15). Do not tighten the screws yet!



Figure 15 Attachment of marking rod clips

3. Slide the marking rods into the clips as shown in Figure 16 and tighten the screws.



Figure 16 Attached marking rod

7.4.6 Securing the SSG-2 on rooftops

As in field installations, the SSG-2 may be employed on rooftops without permanent fastening to the roof. To secure the SSG-2 from strong winds that may displace the unit, place the optional z-profiles along the edges of the SSG-2 and put the concrete slabs onto the z-profiles as shown in the following examples.



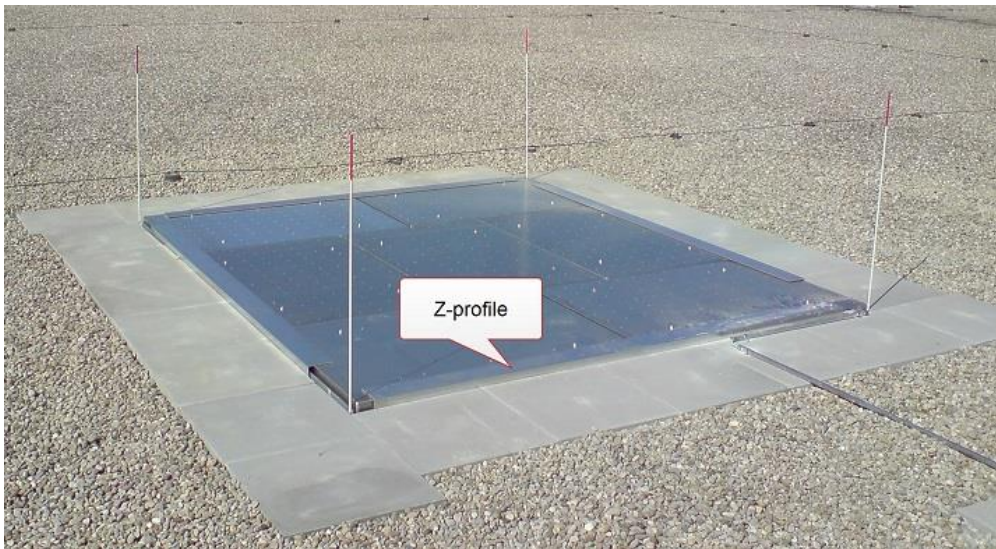
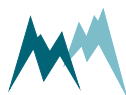
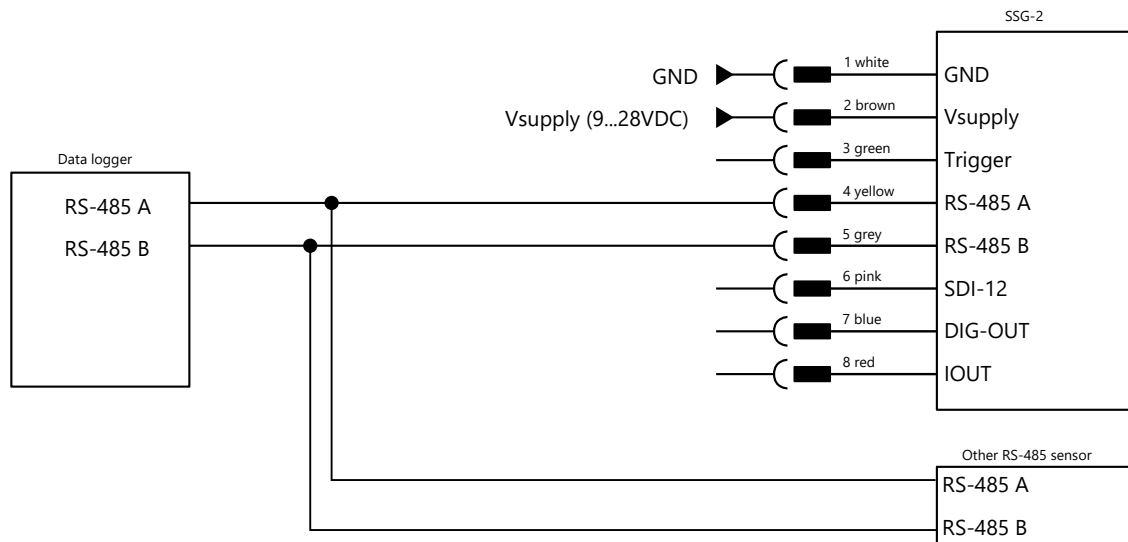

Figure 17 Rooftop mounting with optional z-profiles

7.5 Wiring

7.5.1 RS-485 wiring

Connect the SSG-2 to a data logger or RS-485 network according to the figure below.





ATTENTION

If multiple Sommer Messtechnik devices are connected to a data logger over the same bus, all devices must share the same ground (GND)!

7.5.2 SDI-12 wiring

Connect the SSG-2 to a data logger by SDI-12 according to the figure below.

SDI-12 uses a shared bus with a ground wire, a data wire (indicated as SDI-12) and an optional +12 V wire.



NOTE The connection with the 12 V power supply is optional and depends on the connected SDI-12 master device (typically a data logger).

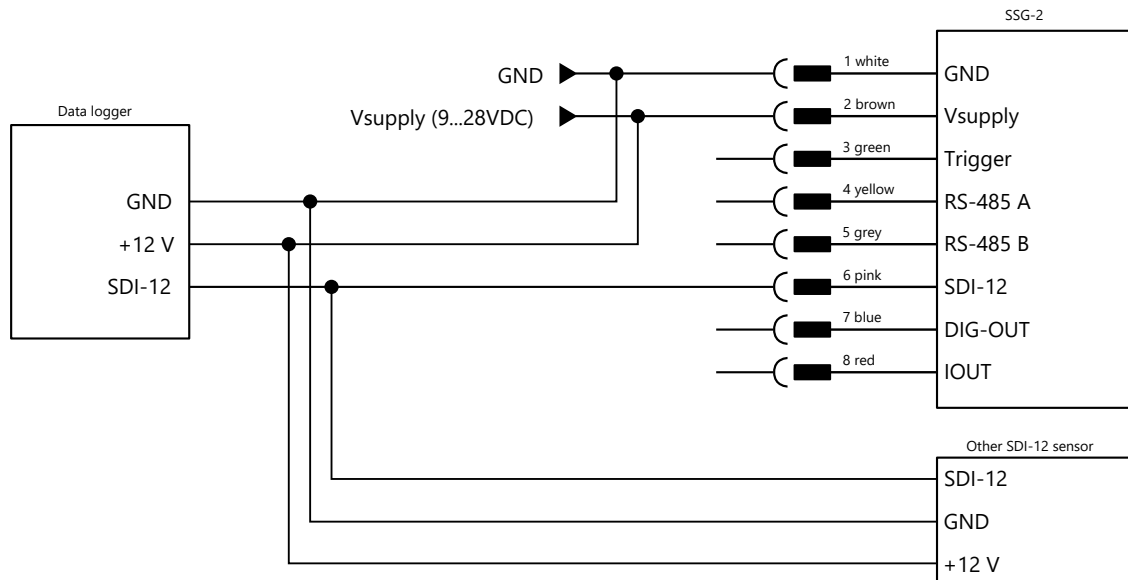
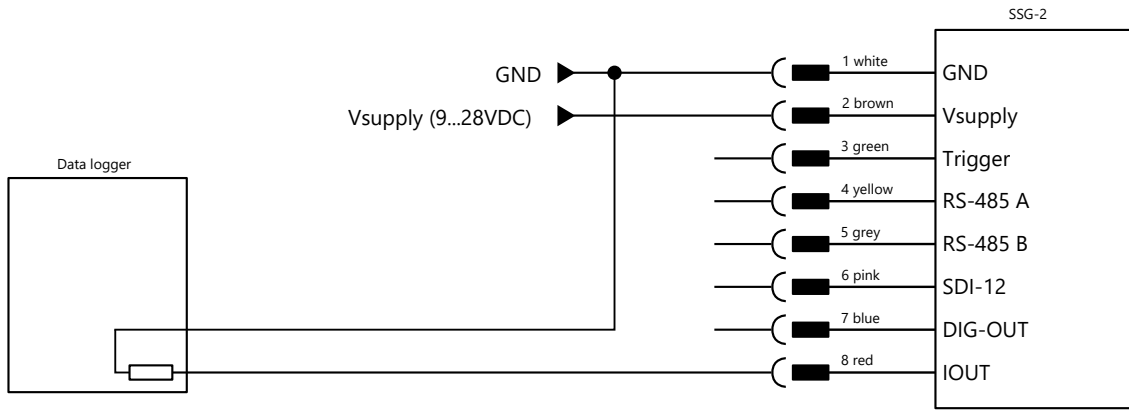

Figure 18 Wiring of the SSG-2 with a data logger via SDI-12

7.5.3 How to wire analog outputs

Connect the analog outputs of the SSG-2 to a data acquisition device according to the figure below.





NOTE If a data logger is connected to the IOUT outputs, the resistance of the logger input(s) must not exceed 200Ω.

7.5.4 How to wire digital outputs

The digital outputs of the SSG-2 can be connected to a data logger according to the figure below.

This is a placeholder snippet for wiring diagrams. Add images here.

Figure 19 Wiring of digital output

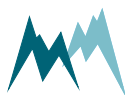

7.6 Testing

To verify the correct readings of the SSG-2, reference weight can be placed on the SSG-2. Follow the steps below to perform a test:

1. Connect the SSG-2 as described in [Connect device to PC](#).
2. Place a car battery, crate or similar of known weight **on the center of the SSG-2**.
3. Run the function [SSG test](#) to initiate a measurement.
4. Check the weight displayed under total weight. In addition, the error code should display 0 (if not see [Error values](#)).
5. If the recorded value deviates from the true weight, remove the object from the SSG-2 and perform a calibration as described in [Calibration](#).



ATTENTION For testing, you must place the reference weight exactly in the middle of the central plate to obtain an accurate reading.

7.7 Start-up

After successful testing, verify that the measurement data are recorded by your data acquisition system and check the data transmission to the remote server if applicable.

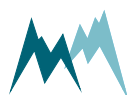

8 Operation

8.1 Connect device to PC

1. Install the Commander support software (see [Installation of Commander](#)).
2. Connect the yellow and gray wires of the sensor cable to the RS-485 to USB converter cable and plug it into your PC as illustrated in the figure below.
3. Connect a 9...28 VDC power supply to the SSG-2 as shown in the figure below.
4. Click on **Communication assistant** on the right-hand side of the Commander window and follow the instructions.
 - a. As **Type of connection** select *Serial connection*
 - b. As **Device type** select *Sensor (9600 Bd)*
 - c. Select **New connection** and select the COM port

During this procedure the communication assistant will search for connected devices. Upon successful completion, the new connection is added to the connections list (tab **Connections (F8)**).

5. In the **Communication** section at the right-hand side of the Commander window select Mode **Connection** and the previously created connection from the drop-down list.
6. Click **Connect** to establish a connection with the SSG-2. If the connection was successful a green icon is displayed at the top-right corner of the Commander window.
7. Select the tab **Parameters (F2)** and click **Download parameters from device** on the left side of the Commander window. The complete parameter list is transferred from the sensor to your PC and displayed in the **Parameter** window.

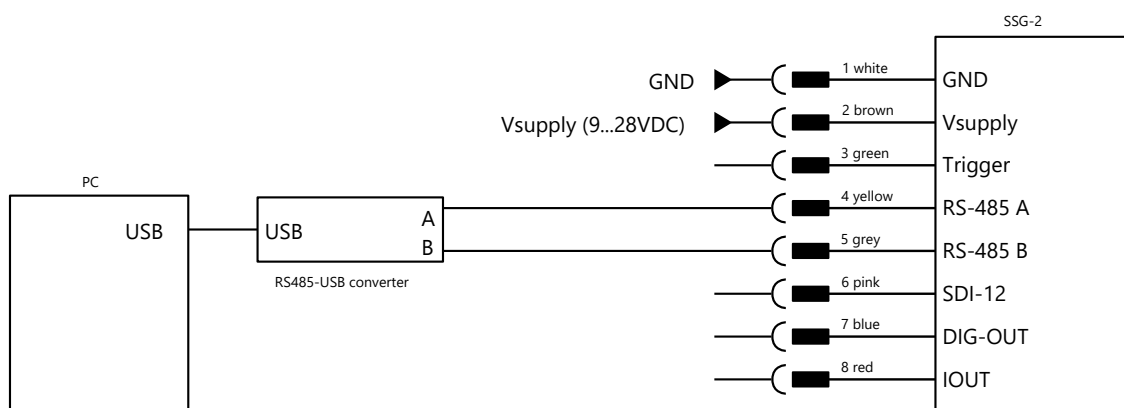

To activate the communication between your device and the Commander software follow the steps described in [Working with connections](#).



9 Maintenance

The SSG-2 generally does not require any special maintenance. However, we recommend to check the following before each winter season:

- Is there any debris, e.g. branches, on the SSG-2 and its vicinity?
- Are the aluminum panels level? Is there any sign of ground deformation or movement?
- Is the signal cable and its protection broken, e.g. damage by rodents?
- Does the SSG-2 read zero? See [Set zero](#) for details.

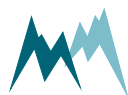

10 Calibration

Should it be required we recommend to perform a zero calibration only.

10.1 Set zero

The SSG-2 is calibrated by adjusting the zero point ([Set zero](#)) with no load on the scale. Perform the zero point adjustment after installation and before each winter season. The zero point can also be checked with the function [Load cell analysis](#).



NOTE To check the zero reading of the SSG-2, or to test a reference weight, use the function [Load cell analysis](#).

10.2 Set span, weight or Set span, SWE

Optionally, the SSG-2 can be calibrated with a span weight. This requires a reference with a mass close to the full scale of the SSG-2.



NOTE Do not use a reference that only covers a fraction of the full scale! This may distort the slope and lead to erroneous readings at high weights!

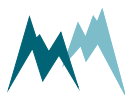

11 Support software Commander

11.1 Software features

The Commander is a multipurpose software tool to configure and operate any Sommer Messtechnik device. It offers the following functions:

- Communication with Sommer Messtechnik sensors and data loggers via serial connection, modem, socket, IP-call and Bluetooth®
- Management of connections and stations
- Configurations of sensors and data loggers
- Live data monitoring and storage
- Data management including download from data loggers and transmission to MDS (Measurement Data server)
- Terminal window to check data transfer and to access device settings directly

11.2 System requirements

The Commander software supports 32- and 64-bit versions of Windows 7 SP1, Windows 8, Windows 8.1, Windows 10 and Windows 11.

For correct operation Microsoft® .NET Framework 4.5 or later must be installed.

11.3 Installation of Commander

Follow the steps below to install the Commander software:

1. Plug the USB stick shipped with the device into your PC.
2. Double-click the [commander.msi](#) installer file on the USB drive.



3. Click **Next** on the pop-up window



4. Read the instructions and click **Next**

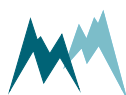
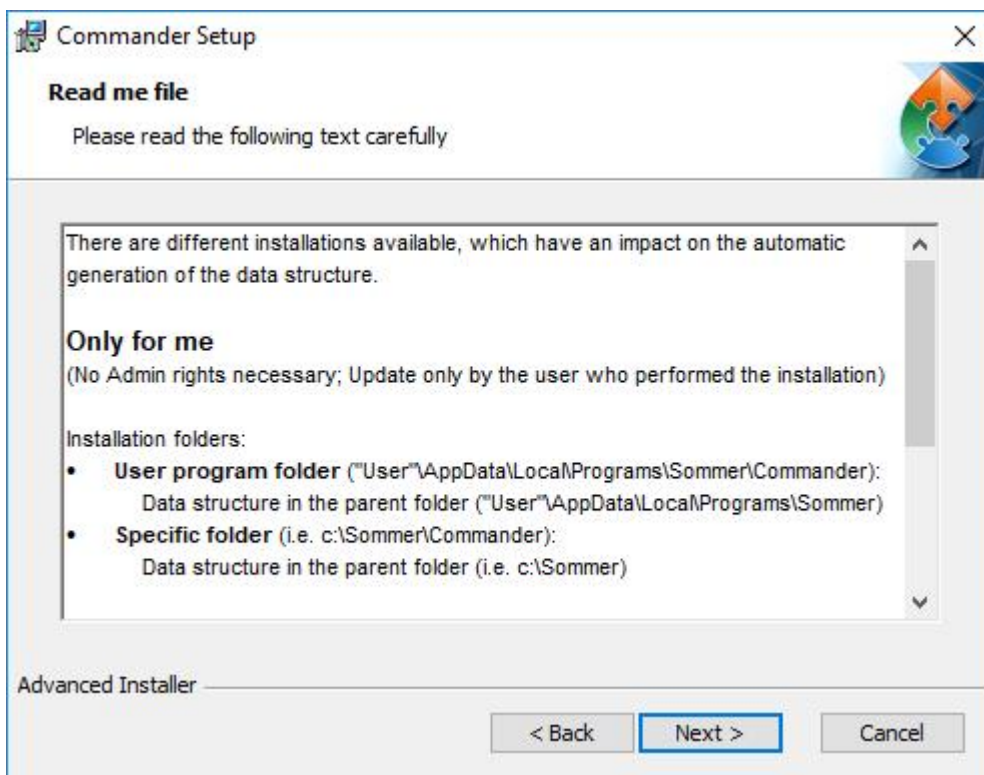

5. Select the installation type and click **Next**

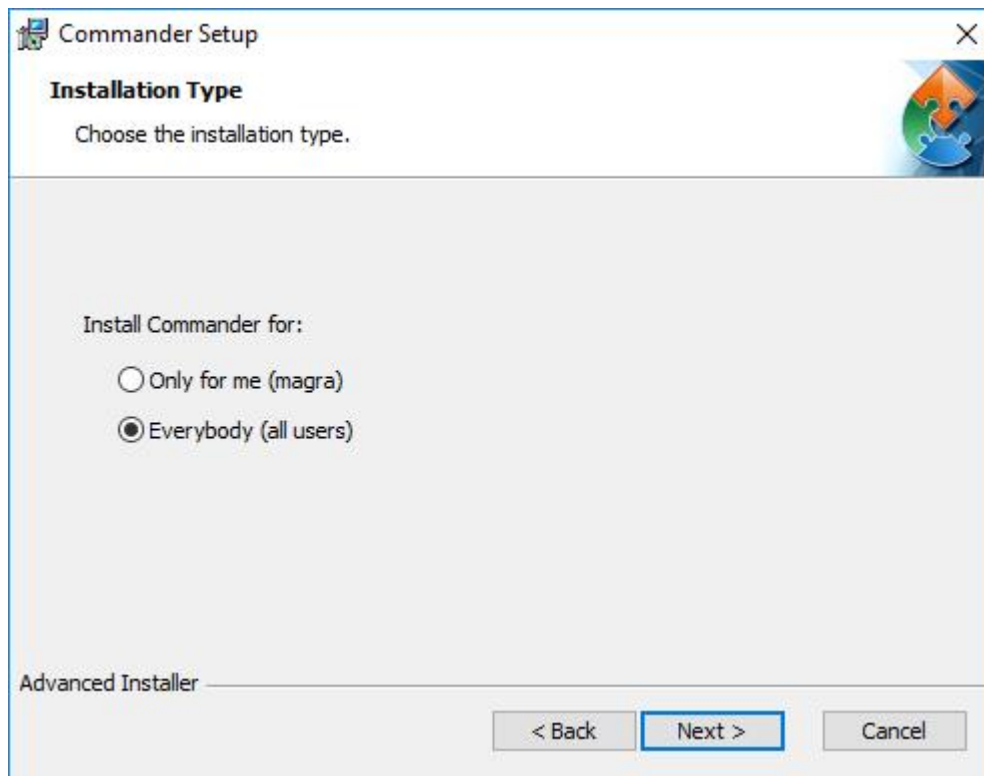

NOTE

Two installation types are available. Depending on the selection, the access rights and the folder structure differ:

Only for me

No admin rights are required. Updates are only available to the user who installed the software.

Installation folders:

- User program folder:
Users\User\AppData\Local\Programs\Sommer\Commander
Data structure:
Users\User\AppData\Local\Programs\Sommer
- Specific folder (default):
C:\Sommer\Commander
Data structure (default):
C:\Sommer





Everybody

Admin rights are required. Updates may only be performed by system administrators.

Installation folders:

- Standard program folder:
Program Files (x86)\Sommer\Commander
Data structure:
Users\Public\Public documents\Sommer
- Specific folder (default):
C:\Sommer\Commander
Data structure (default):
C:\Sommer

6. Select the installation directory and click **Next**

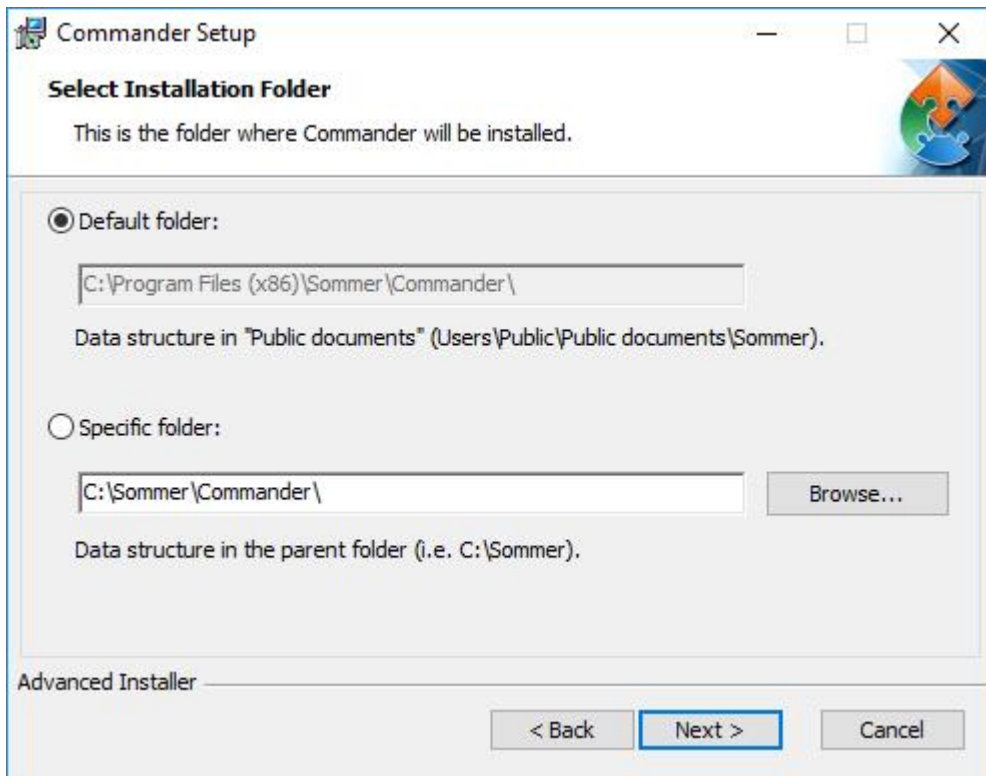

7. Select the features to be installed and click **Next**

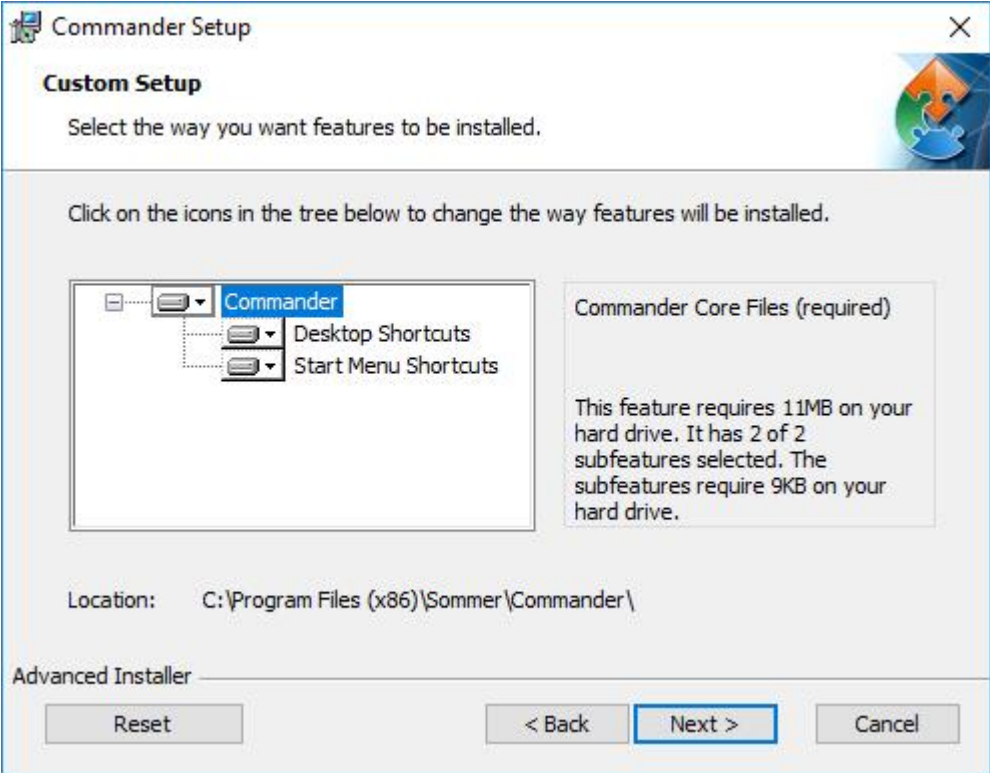

8. Click **Install** to start the installation.

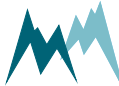
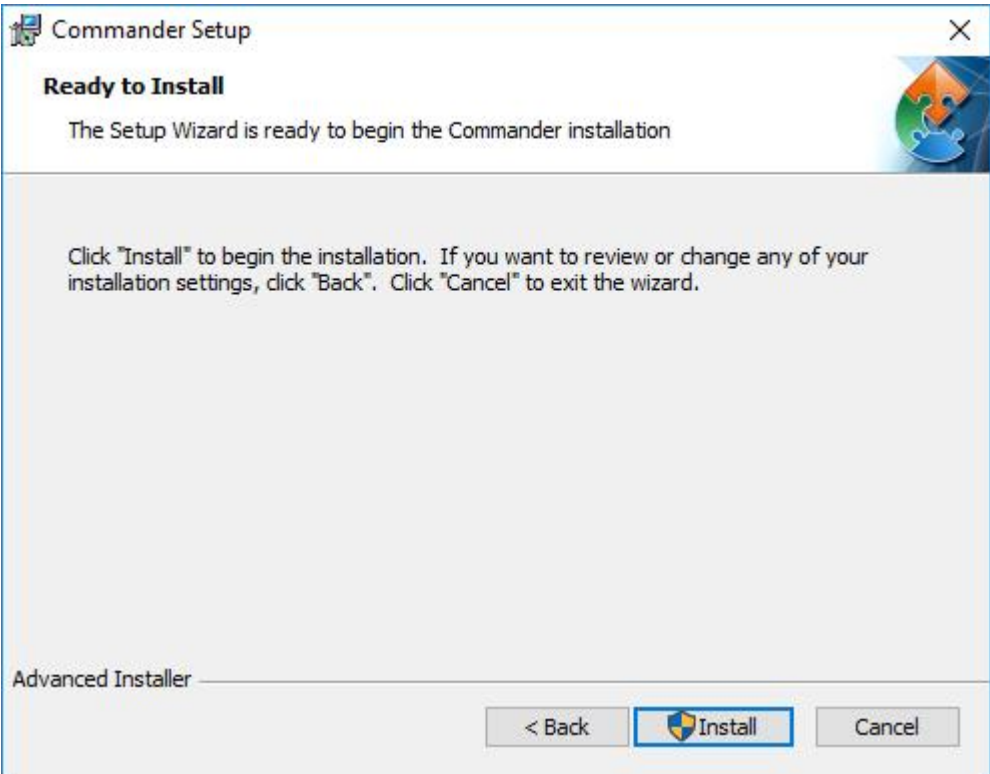

9. Click **Finish** to complete the installation.

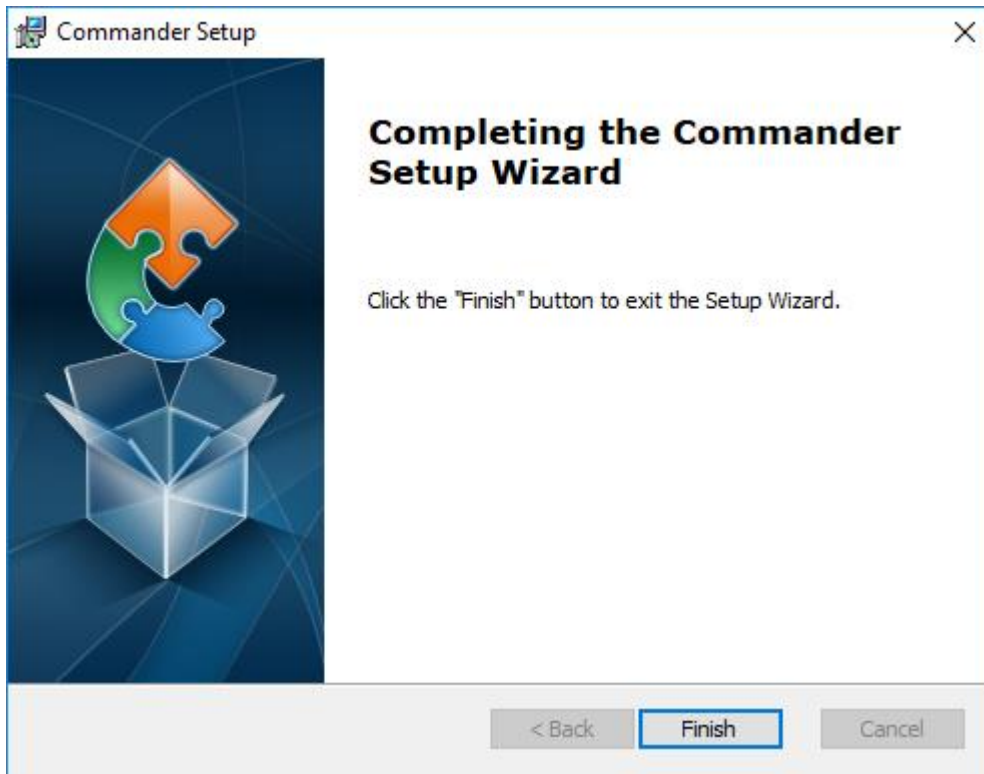

11.4 Working with connections

11.4.1 Establish a connection with the Communication assistant

1. Install the Commander support software as described in [Installation of Commander](#).
2. Connect the device to your PC.
3. Start the Commander software on your PC.
4. Click on **Communication assistant** on the right-hand side of the Commander window and follow the instructions. During this procedure the communication assistant will search for connected devices. Upon successful completion, the new connection is added to the connections list (tab **Connections (F8)**). See also pictures steps 1 to 8 in [Create a station with the Communication assistant](#).
5. In the **Communication** section at the right-hand side of the Commander window select Mode **Connection** and the previously created connection from the drop-down list.
6. Click **Connect** to establish a connection with the SSG-2. If the connection was successful a green icon is displayed at the top-right corner of the Commander window.

To view the settings of the connected device or to read the current measurements, follow the steps described in [Download setup](#) and [Record measurements](#).

11.4.2 Establish a connection manually

1. Install the Commander support software as described in [Installation of Commander](#).
2. Connect the device to your PC.
3. Start the Commander software on your PC.
4. Select the required connection in the [Connections](#) list of the [Connections \(F8\)](#) tab and click [Connect](#). If the connection was successful a green icon is displayed at the top-right corner of the Commander window.
If you don't have the required connection available in the [Connections](#) list, create a new connection as described in [Create a new connection](#).

To view the settings of the connected device or to read the current measurements, follow the steps described in [Download setup](#) and [Record measurements](#).

11.4.3 Create a new connection

1. Select the [Connections \(F8\)](#) tab in the Commander. If the tab is not shown, select it with pressing [F8](#).
2. Click [New connection](#).
3. In the section [Connection settings](#) enter a name of the new connection, e.g. *Serial-com1-9600*, and the connection type, e.g. *Serial connection*.
4. Enter the required information for the selected connection type.
If your SSG-2 is wired to your PC with a RS-485 to USB converter cable, select the port where the device is connected and select a Baudrate of 9800.

11.5 Working with stations

11.5.1 Create a station with the Communication assistant

In order to manage several data loggers, to connect to a data logger via IP-call and to download data, stations can be created in the Commander software. To view a list of all stations select the tab [Stations \(F7\)](#). If the tab is not shown, select it with pressing [F7](#).

Perform the following steps to create a new station with the [Communication assistant](#):

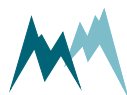

1. Click on **Communication assistant** in the Commander-window

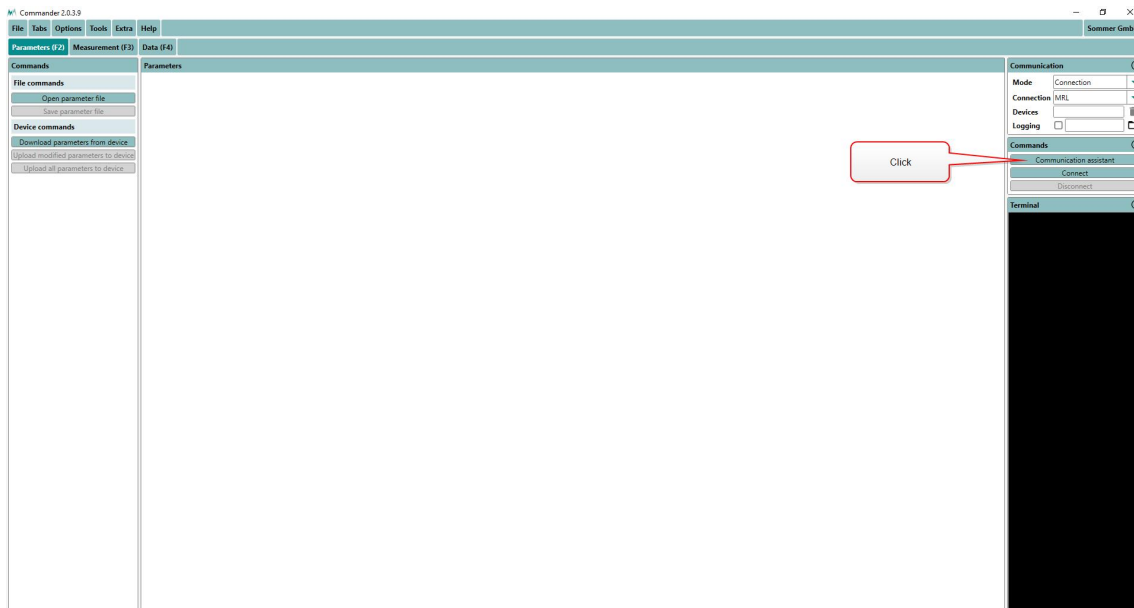

2. In the pop-up window choose the required connection and click **Next**.

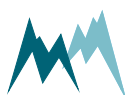
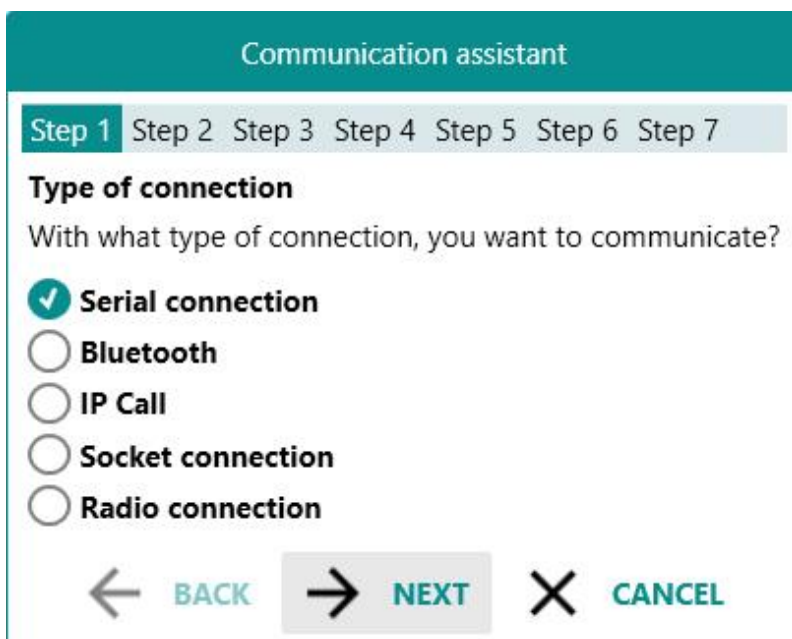

3. Verify that the SSG-2 is connected to your PC and a power supply. Click [Next](#).

Communication assistant

Step 1 **Step 2** Step 3 Step 4 Step 5 Step 6 Step 7

Serial connection: Device fully functional?

Make sure that the device is connected and supplied.
Click "Next" to proceed.

 **BACK**  **NEXT**  **CANCEL**

4. Select [Logger \(115200 Bd\)](#) and click [Next](#).

Communication assistant

Step 1 Step 2 **Step 3** Step 4 Step 5 Step 6 Step 7

Serial connection: Device type

With what type of device, you want to communicate?



Logger (115200 Bd) (MRL-6, MRL-7, RQ-30 ADMS)

Sensor (9600 Bd) (RQ-30, RG-30, SQ-X, SQ-X, SV-a)

Modbus (19200 Bd) (Only for devices set to Modbus)

Or should a port be checked with changing settings?

Check port Baud rate, Parity and stop bits

 **BACK**  **NEXT**  **CANCEL**

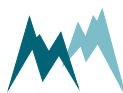

5. Select *Scan ports* and click *Next*.

Communication assistant

Step 1 Step 2 Step 3 **Step 4** Step 5 Step 6 Step 7 Step 8 Step 9

Serial connection: Connection

Do you want to communicate with an existing or new connection?

Baud rate 9600

Existing connection

Connection ▼

New connection

Select port ▼

Scan ports

← BACK → NEXT ✕ CANCEL

6. The Commander now scans all available ports.

Communication assistant

Step 1 Step 2 Step 3 Step 4 **Step 5** Step 6 Step 7 Step 8 Step 9

Serial connection: Scan device

All available serial ports are sequentially scanned for a device.
When the first device is found, the procedure is stopped.

Scan ports

Switch-on standard mode

5/7

Repeat: 5/5

← BACK → NEXT ✕ CANCEL



7. Adopt the *Name* provided by the communication assistant. Click **Next**.

Communication assistant

Step 1 Step 2 Step 3 Step 4 Step 5 **Step 6** Step 7 Step 8 Step 9

Serial connection: New connection
A device has been detected with the connection.
The connection is created.

Name

Type Serial connection

Port

Baud rate 115200

← **BACK** → **NEXT** ✕ **CANCEL**

8. The Commander now scans the selected port for connected devices.

Communication assistant

Step 1 Step 2 Step 3 Step 4 Step 5 Step 6 **Step 7** Step 8 Step 9

Serial connection: Scan devices
All available devices are scanned.

Scan devices
Wake-up device

Devices

7/15

Repeat: 5/5

← **BACK** → **NEXT** ✕ **CANCEL**

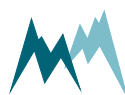

9. Adopt the *Name* of the new station or enter a new name. Click [Next](#).

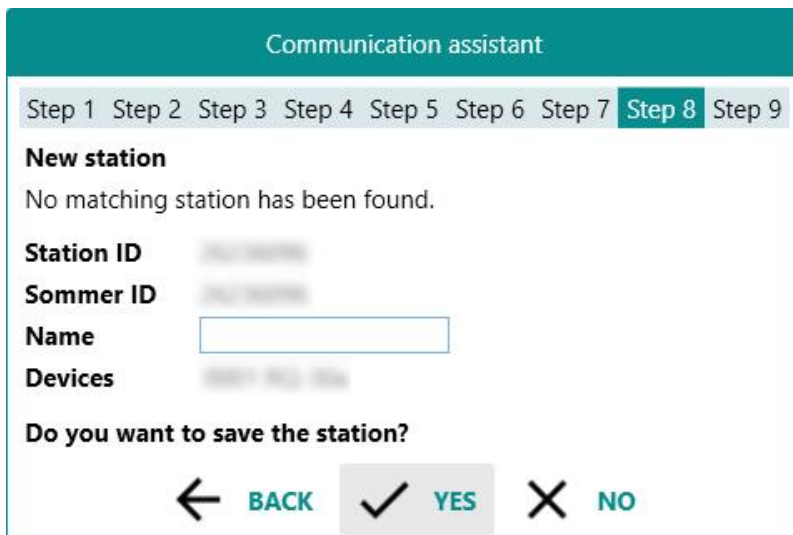

Communication assistant

Step 1 Step 2 Step 3 Step 4 Step 5 Step 6 Step 7 **Step 8** Step 9

New station
No matching station has been found.

Station ID [blurred]
Sommer ID [blurred]
Name
Devices [blurred]

Do you want to save the station?

← BACK ✓ YES ✗ NO

10. A new station has now been created. Click [Finish](#).



Communication assistant

Step 1 Step 2 Step 3 Step 4 Step 5 Step 6 Step 7 Step 8 **Step 9**

Station selected
The station has been selected and can now be used.

← BACK → NEXT ✓ FINISH

11. The newly created station can now be selected in the [Communication](#) section of the Commander. Click [Connect](#) to activate the connection to your device.

11.5.2 Create a station manually

In order to manage several data loggers, to connect to a data logger via IP-call and to download data, stations can be created in the Commander software. To view a list of all stations select the tab [Stations \(F7\)](#).

Perform the following steps to create a new station:

1. In the tab-menu [Stations \(F7\)](#) click [New station](#).
2. Under [Station settings](#) enter the [Station number](#) and [Sommer ID](#). By default both settings are set to the device's serial number (visible on the SSG-2 housing).
3. Select the [Connections](#) used for the station. Multiple selections are possible; the default connection can be selected by ticking the circular field.

- Depending on the connection type, enter the additional information, e.g. **Address** for a Bluetooth connection or **IMSI number** for an IP call.
- Enter the settings for **Data** management. When data are downloaded from a connected SSG-2 they are stored in an archive-file by default. Each archive-file contains the data of a year or month, as selected in **Archive type**. Selection **None** will save all data in one file. The default location for data files is C:\Users\Public\Documents\Sommer\Data\.
- Save the newly created station with the button **Save station**.

11.6 Working with measurements

11.6.1 Poll continuous measurements

- Establish a connection to your device as described in [Working with connections](#).
- Download the setup of your device as described in [Download setup](#).
- Select the **Measurement (F3)** tab.
- In the **Commands** section click **Start polling measurement**.
- Select the option **Polling with measurements**. Now, the Commander will trigger measurements of the SSG-2 without any delays between measurements. The results are displayed **Measurement values** and plotted in the **Measurement data graph**.
- To finish polling mode click **Stop polling**.

The screenshot shows the Commander 2.0.3.9 software interface. The main window is titled 'Commander 2.0.3.9' and has a menu bar with 'File', 'Tabs', 'Options', 'Tools', 'Extra', and 'Help'. The 'Parameters (F2)' tab is active, and the 'Measurement (F3)' sub-tab is selected. The interface is divided into several panels:

- Information:** Shows device details like MRL, Protocol address (0000), Parameter (Synchronized), Serial number, Setup version, Software version, Hardware version, and Time.
- Devices:** Lists the connected device 'MRL 0001'.
- Measurement values:** A table showing the following data:

ID	Name	Value	Unit
0	Self-check	0	
1	Level	49	mm
2	Velocity	1.003	m/s
3	Quality (SNR)	67.05	
4	Flow	5.143	m ³ /h
5	Flow sum		m ³
6	Learned velocity	1.003	m/s
7	Learned flow	5.143	m ³ /h
- Measurement data graph:** A line graph showing 'Flow [m³/h]' on the y-axis (ranging from 0 to 5) over time. A red line represents the flow, which starts at approximately 1.5 m³/h, rises to a peak of about 4.5 m³/h, dips slightly, and then continues to rise towards 5 m³/h. A red callout points to the final data point on the graph, labeled 'Last measurement'.
- Commands:** A panel with buttons for 'Start polling measurements', 'Stop polling', 'Download parameters from device', 'Download parameters from all devices', 'Clear measurement data', and 'Save measurement data'. A red callout points to the 'Start and stop polling' button.
- Terminal:** A black terminal window at the bottom right.



NOTE The polling mode stops automatically after 30 minutes.

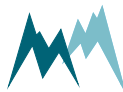

11.6.2 Record measurements

1. Establish a connection to your device as described in [Working with connections](#).
2. Download the setup of your device as described in [Download setup](#).
3. Select the [Measurement \(F3\)](#) tab.
4. Make sure that [Measurement output](#) is set to *Measured values push* or *Storage values push*.
5. If the connection with your device is active, the data will now be displayed in the measurement table and updated at the interval specified in the setup. Also, the incoming data strings are displayed in the [Terminal](#).
6. Click [Save measurement data](#) in the [Commands](#) section to save the recorded measurements. The data are saved as a *.csv file in the SommerXF format.



NOTE You can change the scope of the data output in the setup [Information](#).

11.7 Working with data

11.7.1 View live data

Follow the steps below to view live data acquired from your device:

1. Establish a direct or remote connection with the SSG-2 using the Commander. Use an existing Commander-connection or -station if available.
2. In the [Parameters \(F2\)](#) tab download the parameters of the SSG-2.
3. Now, there are two options to view the measurement data:

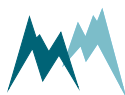

1. If **Measurement output** is set to *Measured values push* or *Storage values push*, data are displayed in the **Measurement (F3)** tab in the specified measurement interval.
2. Open the **Measurement (F3)** tab and click **Start polling measurements**. This measurement mode can be stopped by clicking **Stop polling**, or it is finished automatically after 30 minutes.

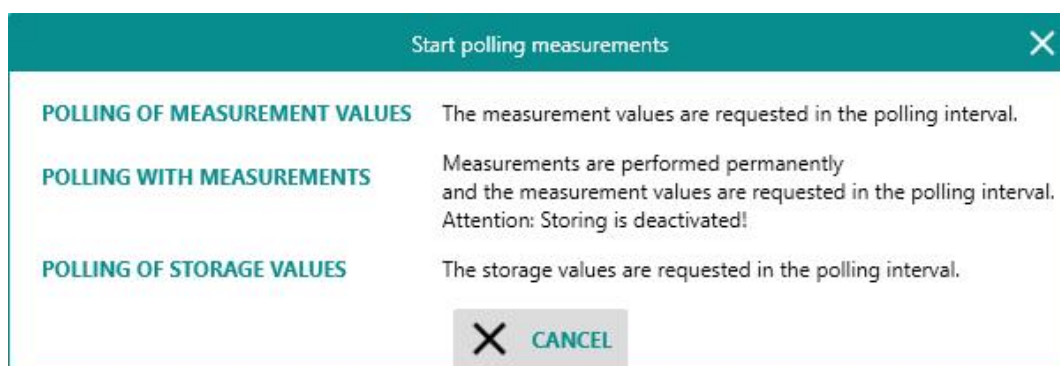

11.8 Working with setups

11.8.1 Download setup

1. Establish a connection to your device as described in [Working with connections](#).
2. Select the **Parameters (F2)** tab in the Commander software.
3. In the **Commands** section click **Download parameters from device**.

The Commander now downloads the setup currently active on the SSG-2. This may take some time if you are downloading the setup for the first time to your PC. Consecutive downloads of a setup with the same version number will be faster as the parameter structure is already available.

You can now save the setup file by clicking **Save parameter file**, or edit the settings as described in [Edit setup](#).



TIP Save the setup on your PC before you make any changes!

11.8.2 Open a setup file

1. Start the Commander on your PC and connect to your SSG-2 either directly with the USB to RS232 isolated converter cable or, if available, the optional Bluetooth connection.

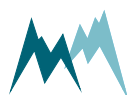

2. Open the [Parameters \(F2\)](#) tab and click [Open parameter file](#). Select the required file (extension .xml or .xmla).

11.8.3 Edit setup

1. Open the setup file as described in [Open a setup file](#) or download it from your device as described in [Download setup](#).
2. Adapt the values of the settings in question and press Enter after each. After you have changed a value, its text box will turn red.



NOTE If you have entered a value outside the data range of the setting, it will be forced to the next valid value! The valid range of each setting is listed in the [Parameter definitions](#).

3. After you have adapted all required settings save the setup file and/or upload the setup to your device by clicking [Upload modified parameters to device](#).
Once the setup has been saved or uploaded, the modified red text boxes will turn white again, indicating that the settings have been saved/applied.

11.8.4 Upload new setup file

1. Establish a connection to your device as described in [Working with connections](#).
2. Select the [Parameters \(F2\)](#) tab.
3. Download the setup currently on the SSG-2 as described in [Download setup](#) and save it by clicking [Save parameter file](#). This step is recommended to have the latest setup available for documentation.
4. Click [Open parameter file](#) and select the required setup file (*.xml) on your PC.
5. Click [Upload all parameters to device](#). This transfers the current setup to the SSG-2.
6. To verify the correct upload click [Download parameters from device](#). This will display the present setup of the SSG-2.

11.9 Update firmware

1. Connect the SSG-2 to your PC with the USB to RS485 isolated converter cable.
2. Make sure no connection is active in the Commander (no green icon at the top-right corner).
3. Click on the menu item [Extra](#) and select [Start Programmer](#).
4. Select the firmware file (*.hex) provided by SOMMER Messtechnik. Make sure the file is stored on your PC and not on a USB or network drive.
5. Choose the COM-port the data logger is connected to and a Baud-rate of 57'600.

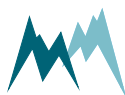

6. Perform the following three steps in short sequence:

- Click **Program**
- Unpower the data logger
- Wait 3...5 seconds to enable full activation of the bootloader and a correct restart (capacitors must be discharged, and if the device had been in sleep mode, this can take some time)
- Repower the data logger

The firmware currently present on the data logger is now erased and the new one copied to the data logger. During the update process the pop-up window may show the following messages:

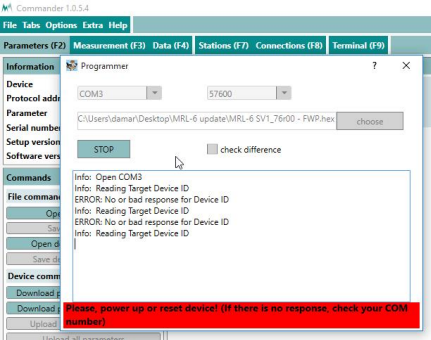

The device is not ready; power needs to be on.

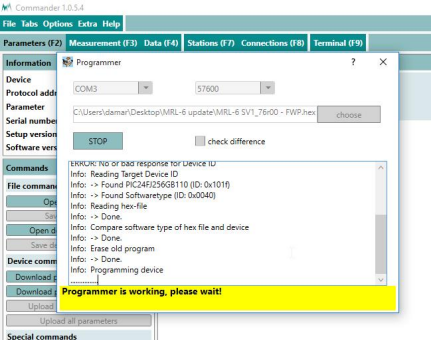

The programmer is active.

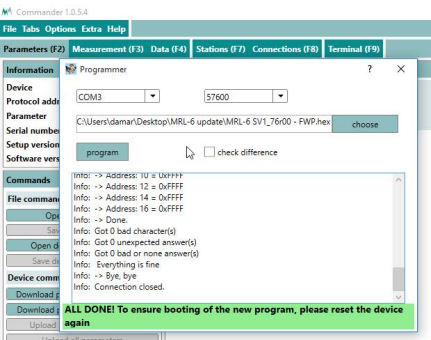

The firmware update has finished.

7. Close the programmer-window as soon as the firmware update has finished.
8. Switch off and repower the data logger again.
9. Open the **Parameters (F2)** tab.

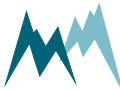

10. Click [Download parameters from device](#). The download of the new parameter list might take a few minutes as the parameter structure may need to be downloaded as well. After completion the new firmware and setup versions will be displayed in the [Information](#) section.

11.10 Change authorization

To prevent unintended changes of parameters in the [Technics](#) menu authorization is generally set to *Normal*. Parameter modifications in [Technics](#) are enabled by switching the authorization level to *Expert* as described below:

1. On the upper tab bar click on [Options](#) and select [Common](#).
2. In the Options window select authorization *Expert* and click [OK](#).

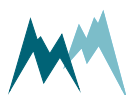
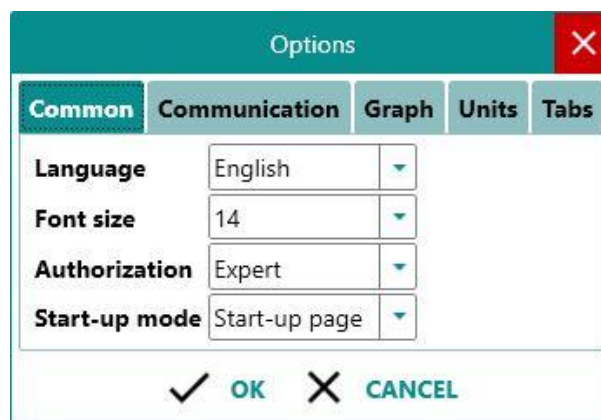

12 Configuration of the SSG-2

12.1 Software tools

The SSG-2 can be configured with one of the following tools:

- Configuration with Commander support software
- Configuration with a terminal program

12.2 Configuration with Commander support software

Follow the steps below to modify the configuration parameters of the SSG-2:

1. Establish a connection between your PC and the SSG-2.
2. Click **Download parameters from device**. The complete parameter list is transferred from the SSG-2 to your PC and displayed in the Parameter window.

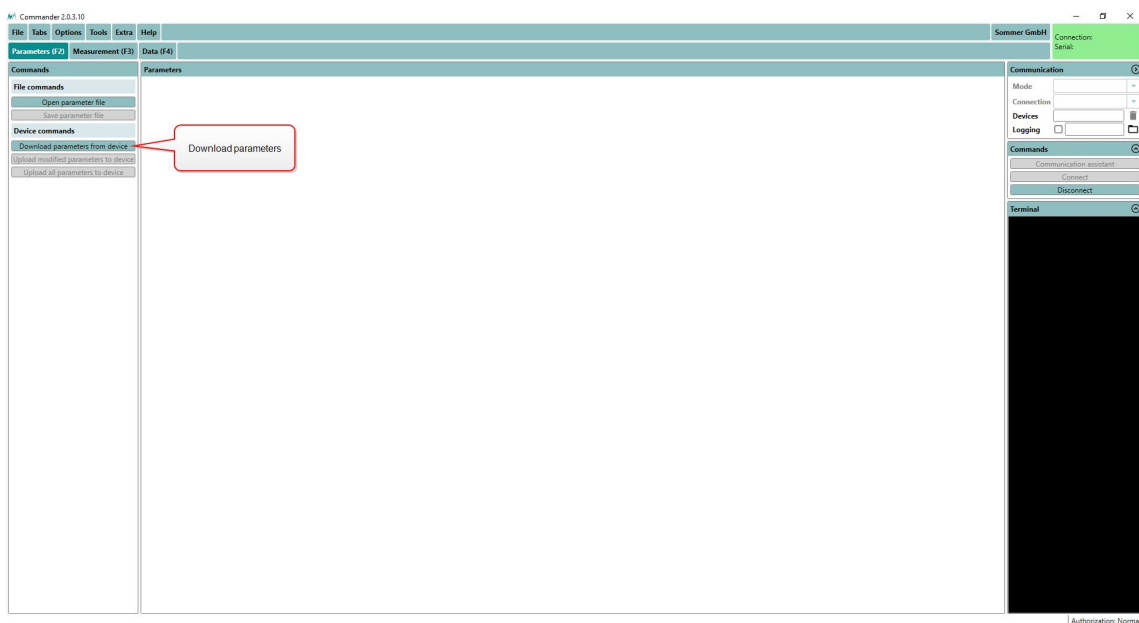



NOTE The first download of the parameter list may take a few minutes. After that the device is known to the PC and consecutive downloads are much faster.



3. Save the parameter file to your PC by clicking **Save parameter file**. This step is recommended to track any configuration changes.

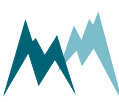
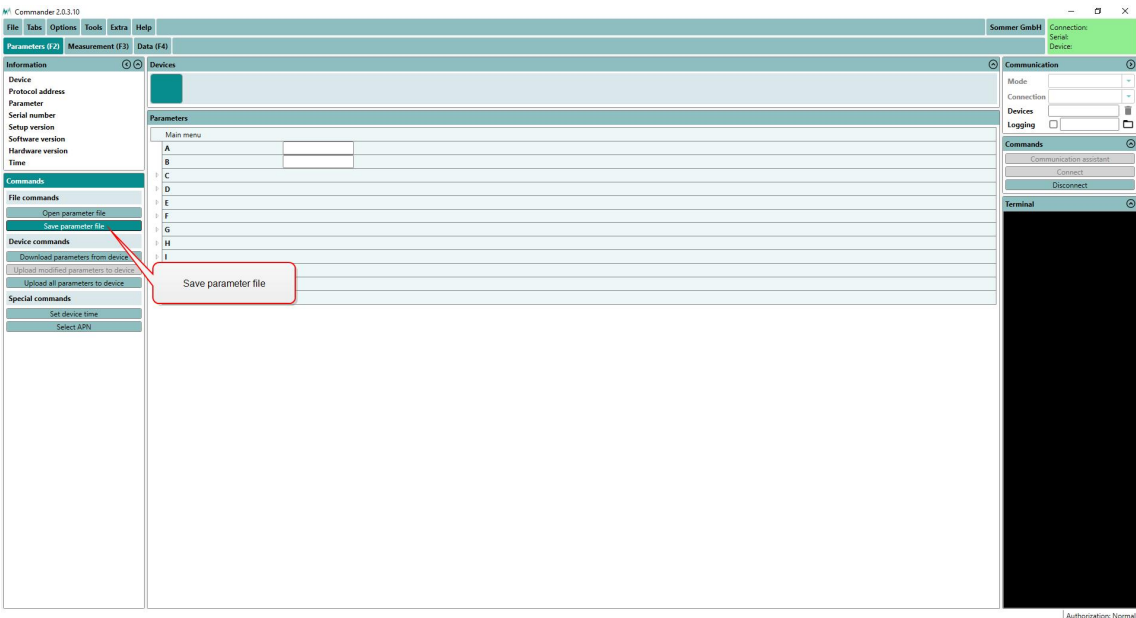

4. Adapt the parameters required for your application. Changed values are displayed with a pink background.

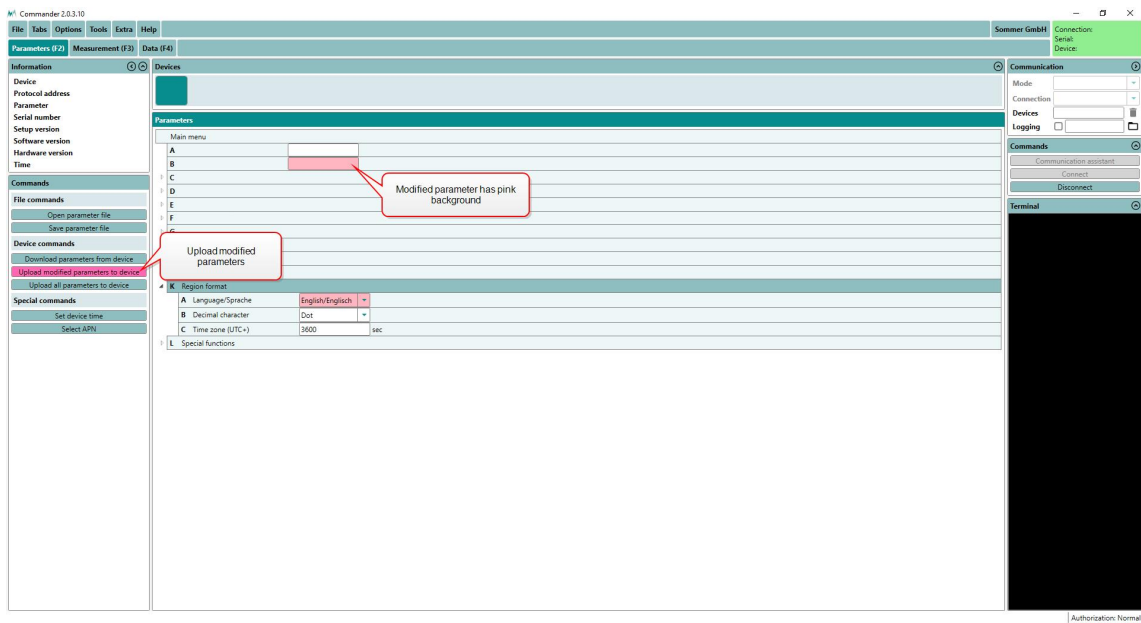

5. Send the modifications to the SSG-2 by clicking **Upload modified parameters to device**. Upon successful upload the pink backgrounds disappear again.



12.3 Configuration with a terminal program

The Commander software ships with an integrated terminal program. However, communication with the SSG-2 can be performed with any terminal program.

Follow the steps below to modify the configuration parameters of the SSG-2:

1. Establish a connection between your PC and the SSG-2.
2. In the terminal window enter three question marks (???) in quick succession. The main parameter menu is displayed in response.

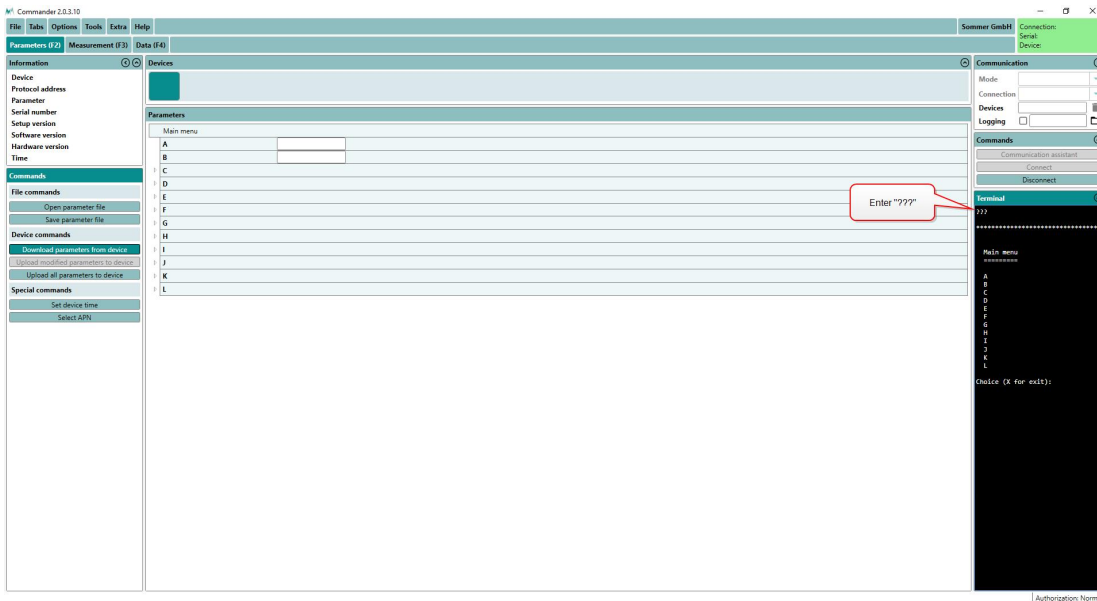

NOTE As an unwanted switching into the menu mode must be avoided the timing of the three question marks ??? is very restrictive and must never be finished with Return/Enter. This is especially important for command line tools, which automatically send a closing "Carriage return". Before and after sending ??? no communication must occur for 1 second.

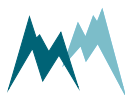

3. Read or modify the required parameters: The menu items can be selected by entering the letter assigned to each item. Upon selection a submenu is opened or the selected parameter is displayed with its unit. Changes to values are confirmed with **Return/Enter** or discarded with **Esc**. Menus are closed with **X** or **Esc**. After closing the main menu with **X** the device performs an initialization.

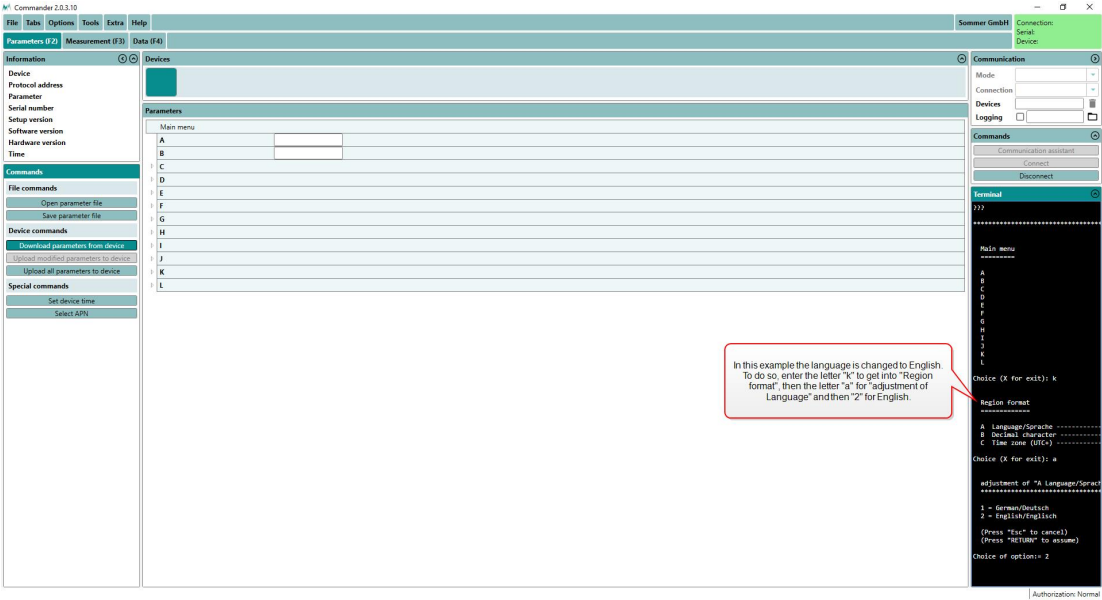

12.4 Conflict messages

During configuration with the Commander software, the SSG-2 may return conflict messages after one or more parameters have been changed and uploaded to the device. An example is shown in Figure 20.

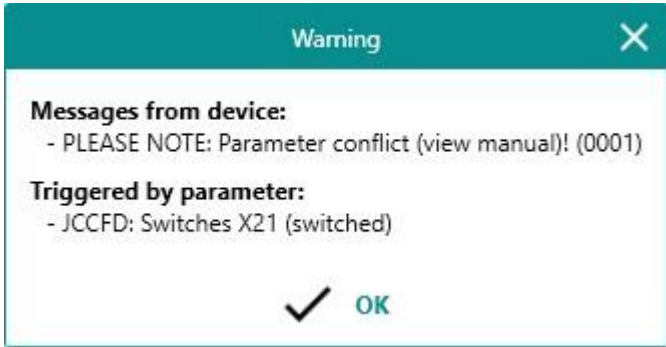
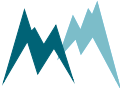

Figure 20 Example of a conflict message

The pop-up window lists the parameters and their indices which have triggered the warning.





ATTENTION If a conflict occurs, invalid settings are replaced automatically with valid values. Verify the values of the conflicting parameters and adapt them if needed!

12.4.1 Setup conflicts

A setup conflict message as listed below is returned if a modified setup with conflicting parameters is loaded onto the SSG-2.

Conflict code	Parameter	Comment
x0001	Measurement output	If <i>Output protocol</i> is set to <i>Modbus</i> , this parameter is set to <i>just per command</i> , as Modbus does not support pushing of data.

Table 2 Setup conflict messages

12.5 General settings

When first setting-up a SSG-2 at a measurement site, the parameters described below may need to be adapted.

12.5.1 Measurement trigger

Measurements are initiated by one of the options listed in the table below.

The commands to trigger measurements via RS-485 and SDI-12 are described in [Communication](#).

Measured data are either returned directly after the measurement or can be requested by commands via the RS-485 or SDI-12 interface. The format of the returned data can be configured in the sub-menu [Output protocol](#).

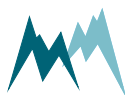

ID	Option	Description
1	Interval (default)	Measurements are initiated in a specified interval.
2	TRIG input	Measurements are triggered by the positive edge of a DC-voltage signal applied to the TRIG input (low: 0 ... 0.6 V, high: 2.2 ... 28 V, pulse duration must be ≥ 500 ms, delay between pulses must be ≥ 500 ms)
3	SDI-12/RS-485	Measurements are externally triggered by commands via RS-485 or SDI-12 from ,e.g. a data logger.
4	all allowed	Measurement is triggered by all options mentioned above.

An internal measurement interval can be set for the SSG-2. If selected in menu item [Measurement trigger](#), measurements are performed in the defined interval. However, a measurement is always completed before a new one is initiated.

12.5.2 Language/Sprache

The menu language.

12.5.3 Decimal character

The character used as decimal separator in the values of the settings, in serial data strings and in .csv files.

12.5.4 Units

The units of snow water equivalent, weight and optional temperature.

12.5.5 Output protocol

The type of the serial output protocol. The following options are available:

ID	Option	Description
1	Sommer (SBP) (default)	Sommer Bus Protocol; data values are returned with an index starting at 1. Multiple strings may be returned.
2	Standard	Standard protocol; data values are returned without an index in one string.
3	MODBUS	Modbus protocol

12.5.6 Information

The main measurement values are always included in the data output string. Additionally, special and analysis values can be included.

ID	Option	Description
1	Main values	Only the main values are returned.
2	& Special values (default)	Main values and special values are returned.
3	& Analysis values	Main, special and analysis values are returned.

12.6 Measurement of snow water equivalent

12.6.1 SSG-2 filter options

To smooth noisy SWE measurements a data filter can be applied. Select the width of the data window with [Filter, no of values](#) and [Filter, type](#).

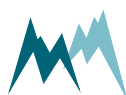

13 Communication

13.1 Communication protocols

The SSG-2 provides the following communication protocols:

- [RS-485](#) (Sommer Bus Protocol)
- [Modbus](#)
- [SDI-12](#)

13.2 Data output

The measurement values returned by the SSG-2 are arranged in a fixed sequence and identified by an index. They are divided into three groups and can be selected in [Information](#).

13.2.1 Main values

Index	Measurement value	Unit	Description
01	SWE	1	Snow water equivalent
02	Load cell temp.	1	SSG-2 device temperature
03	Ground temp.	1	Ground temperature (optional)
04	Error Code	-	see Error values for details

Table 3 Main values

¹Unit according to parameter-menu [Units](#).

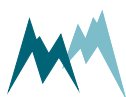

13.2.2 Special values

Index	Measurement value	Unit	Description
05	Load cell 1	1	Weight detected by load cell 1
06	Load cell 2	1	Weight detected by load cell 2
07	Load cell 3	1	Weight detected by load cell 3
08	Load cell 4	1	Weight detected by load cell 4

Table 4 Special values

13.2.3 Analysis values

Index	Measurement value	Unit	Description
09	Error code int.	-	Company internal error code
10	Internal temp.	1	Internal device temperature
11	Supply voltage	V	Value of supply voltage

Table 5 Analysis values

13.2.4 Exception values

Measurement data may be returned with the following exception values:

Value	Description
99999998	Initial value: No measurement has been performed yet.
99999997	Conversion error: Caused by a technical problem.
99999999	Positive overflow
-99999999	Negative overflow

Table 6 Exception values

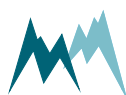

13.2.5 Error values

The error code is a 4-digit number of the format ABCD (e.g. 2301). The 4 digits are defined as follows:

Digit	Error code	Description
A	0	Load cell difference and temperature within limits
	1	Load cell difference exceeded
	2	Temperature limit exceeded
B	0	Temperature probes operate correctly
	1	Error load cell temperature
	2	Error ground temperature
	3	Error load cell temperature and ground temperature
C	0	Load cells 3 and 4 operate correctly
	1	Error at load cell 3
	2	Error at load cell 4
	3	Error at load cell 3 and load cell 4
D	0	Load cells 1 and 2 operate correctly
	1	Error at load cell 1
	2	Error at load cell 2
	3	Error at load cell 1 and load cell 2



EXAMPLE

Error code 1001 Load cell difference exceeded and load cell 1 is the reason.

Error code 230 Ground temperature error and failure of load cells 3 and 4.

Error code 2 Error at load cell 2. Either the load cell was not evaluated correctly, or it was not powered.

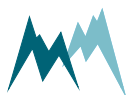

13.3 RS-485

13.3.1 What is RS-485?

RS-485 is a serial communication method for computers and devices. It is currently a widely used communication interface in data acquisition and control applications where multiple nodes communicate with each other.¹

13.3.2 What can I do with it?

RS-485 communication is primarily used to trigger measurements and read their results. It also permits to change parameters of the SSG-2.

13.3.3 Configuration

The SSG-2 has serial RS-485 communication enabled by default. If the device is integrated into a RS-485 network or connected to a stand-alone data acquisition system, e.g. a data logger, the parameters listed in [RS-485 \(COM\)](#) may need to be adapted.

13.3.3.1 System key and device number

The system key and device number are used to identify a SSG-2 in a bus system. This is essential if multiple devices (SSG-2 and data loggers) are operated within the same system.

System key

The system key separates different conceptual bus systems. This may be necessary if the remote radio coverage of two measurement systems overlap. In wired setups, the system key should be set to *00*.

Device number

The device number is a unique number that identifies a device in a bus system.



ATTENTION Do not use a device number twice in your bus system! Otherwise communication will fail!

¹<https://www.lammertbies.nl/comm/info/RS-485.html>

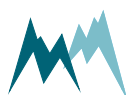

13.3.3.2 Measurement output

The serial data output can be triggered in the following ways:

ID	Option	Description
1	Just per command	The output is only requested by commands via RS-485.
2	After measurement (default)	The serial data output is performed automatically right after each measurement.
3	Pos. TRIG slope	The output is triggered by a positive edge of a control signal applied to the trigger input.



NOTE If **Measurement output** is set to *pos. TRIG slope*, the data are returned with a delay of 200 ms after the trigger has been set. Make sure that your data acquisition system takes account of this lag to ensure that it receives the most recent data.

13.3.3.3 Operation modes

The selected combination of measurement trigger and output time determines the following operation modes:

Parameter	Mode		
	Pushing	Polling	Apparent polling
Measurement trigger	internal	TRIG input SDI-12/RS485	TRIG input SDI-12/RS485
OP, measurement output	after measurement	just per command	after measurement

13.3.3.4 Waking-up a connected data logger

The SSG-2 supports wake-up of a connected data logger that is in standby mode. Generally, this feature is only used in pushing and can be set under [Wake-up sequence](#).

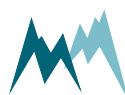

13.3.3.4.1 Sync sequence

The sync sequence is the string `UU~??` and is sent directly before a command. It is used to synchronize the receiving UART.

13.3.3.4.2 Prefix

The prefix is an arbitrary character; the SSG-2 uses a blank. This character is sent prior to any communication. Then the time of the [Prefix holdback](#) is waited and the command is sent afterwards. With this procedure the receiving device has time to wake-up.

13.3.3.5 Output protocols

For data output via RS-485 different protocols are available, which can be selected under [Output protocol](#).

13.3.4 Data output options

Data are returned in two different formats, selectable in [Output protocol](#):

- [Sommer Bus Protocol \(SBP\)](#)
- [Standard protocol](#)

13.3.5 Sommer Bus Protocol (SBP)

The data string of the Sommer Bus Protocol has the following format:

 **EXAMPLE** #M0001G01se01 1461|02 1539|03 25.25|04
0|ADC9;

A data string contains max. 8 values and is max. 105 characters long.

13.3.5.1 Header

The header (`#M0001G01se`) identifies the data by system key, device number and string number.

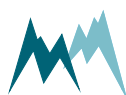

Parameter	Format	Description
Start character	#	
Identifier	M	M identifies an output string
System key	dd	
Device number	dd	
Command ID	G	G defines an output string with string number
String number	dd	01 Main values 03 Special values 05 Analysis values 06 Analysis values
Command	se	se identifies automatically sent values

Table 7 Header of the Sommer Bus Protocol

13.3.5.2 Measurement value

A measurement value (02 1539|) has a length of 8 digits and is returned together with its index. If the measurement value is a floating point number, one digit is reserved for the decimal character. Values are returned right-aligned, so blanks may occur between index and value.

Parameter	Format	Description
Index	dd	2 numbers
Value	xxxxxxxx	8 character right-aligned
Separator		

Table 8 Values in Sommer Bus Protocol

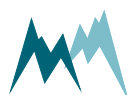

13.3.5.3 End sequence

The data string is terminated with a CRC-16 in hex format (ADC9) followed by an end character and <CR><LF>. The CRC-16 is described in [Sommer Messtechnik CRC-16](#).

Parameter	Format	Description
CRC-16	hhhh	4-digit hex number
End character	;	
Control characters	<CR><LF>	Carriage return and Line feed

Table 9 End sequence of the Sommer Bus Protocol

13.3.5.4 Example Sommer Bus Protocol

13.3.5.4.1 Main values

Main values are returned as in the following example:

 **EXAMPLE** #M0001G00se01 12.8|02 22.14|03 |04
0|A94A;

#M0001G00se	Header with system key 00, device number 01 and string number 00
01 12.8	SWE
02 22.14	Load cell temp.
03	Ground temperature (no sensor connected or it is switched off)
04 0	Error Code
A94A;	Closing sequence

Table 10 Main values in Sommer Bus Protocol

13.3.5.4.2 Special values

Special values are returned as in the following example:

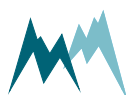



EXAMPLE #M0001G01se05 3.0|06 3.0|07 3.1|08
3.2|9426;

#M0001G01se		Header with system key 00, device number 01 and string number 01
05	3.0	Load cell 1
06	3.0	Load cell 2
07	3.1	Load cell 3
08	3.2	Load cell 4
9426;		Closing sequence

Table 11 Special values in Sommer Bus Protocol

13.3.5.4.3 Analysis values

Analysis values are returned as in the following example:



EXAMPLE #M0001G02se09 0|10 26.18|11
13.31|3152;

#M0001G02se		Header with system key 00, device number 01 and string number 02
09	0	Error code int.
10	26.18	Internal temp.
11	13.31	Supply voltage
3152;		Closing sequence

Table 12 Analysis values in Sommer Bus Protocol

13.3.6 Standard protocol

The data string of the Standard protocol has the following format:



EXAMPLE M_0001 1461 1539 25.25 0

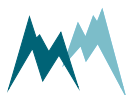

13.3.6.1 Header

The header (M_0001) identifies the data by system key and device number.

Parameter	Format	Description
Identifier	X_	M_ Measurement values S_ Special values V_ Analysis values
System key	dd	
Device number	dd	

Table 13 Header of the Standard protocol

13.3.6.2 Measurement values

Measurement values are returned in sequence and are separated by a blank. A measurement value has a length of 8 digits. If the measurement value is a decimal number, one digit is reserved for the decimal character. Values are returned right-aligned, so additional blanks may be returned between values.

Parameter	Format	Description
Separator	[blank]	blank
Value	xxxxxxxx	8 character right-aligned

Table 14 Values in Standard protocol



NOTE With the standard protocol the data strings can be very long. In contrast, the strings of the Sommer Bus Protocol are max. 105 characters long.

13.3.6.3 End sequence

The data string is terminated with <CR><LF>.

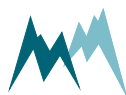

13.3.6.4 Example Standard protocol

13.3.6.4.1 Main values

Main values are returned as in the following example:

 EXAMPLE M_0001	12.8	22.14	0
M_0001	Header with identifier for measurement values		
12.8	SWE		
22.14	Load cell temp.		
	Ground temperature (no sensor connected or it is switched off)		
0	Error Code		

Table 15 Main values in Standard protocol

13.3.6.4.2 Special values

Special values are returned as in the following example:

 EXAMPLE S_0001	3.0	3.0	3.1	3.2
S_0001	Header with identifier for measurement values			
3.0	Load cell 1			
3.0	Load cell 2			
3.1	Load cell 3			
3.2	Load cell 4			

Table 16 Special values in Standard protocol

13.3.6.4.3 Analysis values

Analysis values are returned as in the following example:



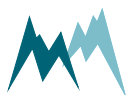

EXAMPLE v_0001 0 26.18 13.31

z_0001	Header with identifier for analysis values
0	Error code int.
26.18	Internal temp.
13.31	Supply voltage

Table 17 Analysis values in Standard protocol

13.3.7 RS-485 commands

13.3.7.1 Command structure

The structure of serial commands and answers is described in the following table:

Parameter	Format	Description
Start character	#	
Identifier	X	<p>W Write: SSG-2 returns a confirmation on receipt. This command type demands a closing sequence with a valid CRC-16.</p> <p>S Silent: SSG-2 does not acknowledge the receipt of the command. This command type demands no closing sequence and therefore no CRC-16.</p> <p>R Read: SSG-2 returns the requested measurement value or parameter. This command type demands a closing sequence with a valid CRC-16.</p> <p>T Temporary: Write a volatile, temporary setting and receive a confirmation.</p> <p>A Answer: Answer of device to read or write command.</p>
System key	dd	

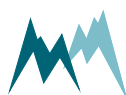

Parameter	Format	Description
Device number	dd	
Command	xxx	See table in section Commands .
Separator		
CRC-16	hhhh	4-digit hex number
End character	;	

Table 18 Structure of Sommer Bus Protocol commands and answers

13.3.7.2 Commands

The following commands can be used with the SSG-2:

Command	Description
\$mt	Trigger a measurement
\$pt	Return measurement values
XX	Read a parameter with identifier XX
XX=xxxx	Write a parameter with identifier XX and the value xxx

Table 19 List of Sommer Bus Protocol commands

13.3.7.3 Trigger a measurement

The command \$mt triggers a complete measurement sequence as in the following example:

	EXAMPLE #W0001\$mt BE85;	Answer: #A0001ok\$mt 4FA9;
---	---------------------------------	----------------------------

13.3.7.4 Read a parameter value

Read measurement interval (in the example below the menu item B):

	EXAMPLE #R0001B 228B;	Answer: #A0001B=300 F8B3;
---	------------------------------	---------------------------



13.3.7.5 Request a complete data string

The command `$pt` requests a data string as in the following example:



EXAMPLE

Option 1

```
#W0001$pt|7D19;           Answer: #A0001ok$pt|8C35;
```

Option 2

```
#S0001$pt|                Answer: none
```

The data string is returned as soon as the SSG-2 has processed the command. If a wrong command is entered, the device returns `#A0001na$pt|3D40;`.

13.3.7.6 Request a single measurement value

The reading command `R` together with the index of the requested measurement returns a single measurement value. In the following example the measurement value with index `01` is requested:



EXAMPLE

Measurement Value cv:

```
#R0001_010cv|EA62;   Answer: #A0001ok_010cv1461   |5D62;
```

Storage Value sv:

```
#R0001_010sv|F853;   Answer: #A0001ok_010sv1461   |1D31;
```

13.3.8 Sommer Messtechnik CRC-16

The CRC-16 (cyclic redundancy check) used in data transmission of Sommer Messtechnik devices is based on the ZMODEM protocol. When data are exchanged between two devices the receiving device calculates the CRC-value. This value is compared to the CRC value sent by the other device to check if the data were transmitted correctly. Please refer to technical literature or contact Sommer Messtechnik for calculation of CRC-16 values.

You can [here](#) calculate the CRC of a command online .

If you need to compute CRCs automatically, you can implement the following procedure in your data logger or controller software.

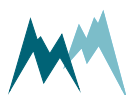

The CRC-16 is calculated character by character. The start value for the initial CRC-16 calculation is always 0.

The following procedure returns the CRC-16 of a single character:

```

byte1 = CRC-16 right shift by 8 bits           upper byte disappears
uint1 = c                                     new character, upper byte = 0
uint2 = CRC-16 left shift by 8 bits           lower byte = 0
uint3 = crc16tab[byte1]                       Table value from the CRC-16 table
Crc16 = uint3 (excl. or) uint2 (excl. or) uint1

```

Computation CRC-16 in C/C++

```
1 | crc16 = crc16tab[(unsigned char)(crc16>>8)] ^ (crc16<<8) ^ (unsigned int)(c);
```

The `crc16tab` array is listed in [CRC-16 array](#).



EXAMPLE

Command to request measurement data `#W0001$pt|7D19;`

The first character is #, the last |. The CRC-16 of the command is 7D19 and its end character is ;.

The CRC-16 is calculated sequentially with the start value 0 for the initial CRC-16 calculation:

Position	String	CRC-16
Start		0000
0	#	0023
1	#W	2357
2	#W0	4331
3	#W00	4997
4	#W000	4EDD
5	#W0001	743B
6	#W0001\$	0537
7	#W0001\$p	67D5
8	#W0001\$pt	C935
9	#W0001\$pt	7D19

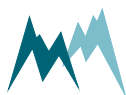

13.4 SDI-12

13.4.1 What is SDI-12?

SDI-12 (Serial Data Interface at 1200 Baud) is a serial data communication standard for interfacing multiple sensors with a single data recorder. For a detailed description on SDI-12 communication please refer to www.sdi-12.org.

13.4.2 What can I do with it?

The SSG-2 listens to standard SDI-12 commands as listed in the SDI-12 specifications of version 1.3, e.g., to trigger a measurement or retrieve measurement results. Additionally, a set of extended SDI-12 commands is implemented in all SOMMER sensors for instrument configuration.

13.4.3 Configuration

The SSG-2 has SDI-12 communication enabled by default. When setting up a SDI-12 network take the following considerations into account:

- Each device in the SDI-12 network must have a unique address, e.g. data logger address **0**, SSG-2 address **1**.
- If the SSG-2 operates in polling mode (**Measurement trigger** set to **SDI-12/RS-485**), measurements are triggered by **M!** commands and data are retrieved by **D!** commands.
- If the SSG-2 operates in pushing mode (**Measurement trigger** set to **interval**), data are retrieved by the **R!** commands.
- When multiple sensors are connected to the same network, data acquisition should be done in sequence, i.e., data should have been received from the first sensor before triggering the measurement of the second sensor.
- Most data loggers control the timing of messages (marking and spacing) automatically. If this is not the case, please refer to www.sdi-12.org.

13.4.4 Data structure

The answer from the SDI-12 device is a string containing the sensor address, the requested data and a terminating carriage return/line feed.

In a string containing measurement data, the measurements are returned in the same order as listed by the index in [Data output](#).

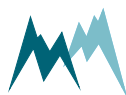

**EXAMPLE**

```
0+2591+706+25.53+62<CR><LF>
```

Value	Content
0	Sensor address
2591	Measurement with index 01
706	Measurement with index 02
25.53	Measurement with index 03
62	Measurement with index 04

If a device returns more than 9 measurement values, or if the values are returned in groups (see also [Request results](#)) the measurement index increments in the next group.

**EXAMPLE**

```
0D0! Answer: 0+2591+706+25.53+62<CR><LF>
```

```
0D0! Answer: 0+56.2+125+12.32<CR><LF>
```

Value	Content
0	Sensor address
2591	Measurement with index 01
706	Measurement with index 02
25.53	Measurement with index 03
62	Measurement with index 04
0	Sensor address
56.2	Measurement with index 05
125	Measurement with index 06
12.32	Measurement with index 07

13.4.5 SDI-12 commands

The following tasks can be performed with standard and extended SDI-12 commands.

Extended SDI-12 commands are non-standard commands implemented by SOMMER to enable device configuration via SDI-12.

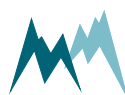



NOTE After any changes, the settings have to be adopted with the command `aXW_ts|!`, with `a` the sensor address.

13.4.5.1 Command structure

A standard SDI-12 command starts with the sensor address and ends with an exclamation mark, e.g., `0M!` to trigger a measurement.

Configuration commands contain additional information; see the sections below for details.

13.4.5.2 Identify device

The identification of a SDI-12 device is requested with the command `aI!`, with `a` the sensor address.



EXAMPLE

```
0I!      Answer 013Sommer  USH  140r90 USH-9  <CR><LF>
```

The answer contains the following information:

0	SDI-12 address
1	SDI-12 version prior to the point
3	SDI-12 version after the point
Sommer	Description of the company (6 characters and 2 blanks)
USH	Description of the firmware (5 characters and 2 blanks)
140r90	Firmware version (6 characters and 2 blanks)
SSG-2	Device designation (max. 13 characters)

13.4.5.3 Acquire measurements

To acquire a measurement from a sensor, two individual SDI-12 commands – trigger a measurement and request measurement values – need to be sent.



EXAMPLE

```
0M!      Answer: 00084<CR><LF>  and  0<CR><LF>  after 8 seconds
```

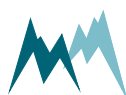



`0D0!` Answer: `0+2591+706+25.53+0<CR><LF>`

The first values in the response to the `aDn!` command is the sensor address.

13.4.5.4 Trigger measurement

The command `aM!` with sensor address `a` triggers a measurement as in the example below.

The response states the measurement duration and the number of measurement values (see example below). After completion of the measurement, the device will return an additional `a<CR><LF>`, with `a` the sensor address.



EXAMPLE

`0M!` Answer: `00084<CR><LF>` and `0<CR><LF>` after 8 seconds

The answer contains the following information:

<code>0</code>	SDI-12 address
<code>008</code>	Duration of the measurement in seconds
<code>4</code>	Number of measurement values

13.4.5.5 Request results

After each measurement, results are requested with the command `aDn!`, with `a` the sensor address and `n` the index of the returned data string.



EXAMPLE `0D0!` Answer: `0+2591+706+25.53+0<CR><LF>`

The leading `0` of the response is the sensor address.

Generally, the command `aD0!` is sufficient to request up to 9 measurement values. If more than 9 values need to be read, or if the values are returned in groups, the commands `aD1!`, `aD2!`,... may need to be issued after `aD0!`. For example, if a measurement returns 8 values in two groups of 4, the commands `aD0!` and `aD1!` need to be issued to receive all values.

13.4.5.6 Acquire continuous measurements

If the SDI-12 device is operating in continuous measurement mode (not polled by SDI-12), the command `aR0!` will request and return the current reading of the sensor. The values within the data

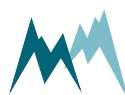

string follow the order listed in the measurement table. The first values in the response to the `aRn!` command is the sensor address.



EXAMPLE

`0R0!` Answer: `0+2591+706+25.53+0<CR><LF>`



ATTENTION

If more than 8 values need to be read, or if the values are returned in groups, the commands `aR1!`, `aR2!`,... may need to be issued after `aR0!`. For example, if a measurement returns 8 values in two groups of 4, the commands `aR0!` and `aR1!` need to be issued to receive all values.

13.4.5.7 Configure parameter

The configuration parameters of a SOMMER sensor are read with the command `aXRpp!` and written with the command `aXWpp=vvv!`, with `a` the sensor address, `pp` the parameter identifier and `vvv` the value of the parameter.

13.4.5.8 Read and write a parameter



EXAMPLE

Reading of measurement interval (in this example menu item B)

`0XRB|!` Answer: `0B=300|<CR><LF>`

Setting of measurement interval to 60 s (in this example menu item B)

`0XWB=60|!` Answer: `0B=60|<CR><LF>`

13.4.5.9 Read and write a selector-parameter

Changing the measurement trigger (in the following example menu item A) from *interval* to *SDI-12/RS485*:



EXAMPLE

`0XRA|!` Answer: `0A=1|<CR><LF>`

`0XWA=3|!` Answer: `0A=3|<CR><LF>`

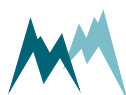

13.4.5.10 Read and write a parameters of a table

Some SOMMER sensors are equipped with multiple transducers and their settings are listed in a table (see example below). A value within such a table is addressed by its row-index (01, 02 ...) and column-index (A, B ...). A corresponding SDI-command has the following format:



EXAMPLE

In this example of a snow scale the value in row 01 and column B of the parameter D-D-E is changed to -1.4.

0XWDDE01B=-1.4|!

Answer: 0DDE01b=-1.4|<CR><LF>

	Identifier	offset zero kg	gain	zero default kg	gain default
01	Load Cell 1	-1.4	0,997787	0,000	0,997787
02	Load Cell 2	0,000	0,997787	0,000	0,997787
03	Load Cell 3	0,000	0,997787	0,000	0,997787
04	Load Cell 4	0,000	0,997787	0,000	0,997787

13.4.5.11 Adopt settings

Some settings need to be adopted with the command `aXW_ts|!`, with `a` the sensor address. It is recommended to issue `aXW_ts|!` after each configuration change.

13.5 Modbus

13.5.1 What is Modbus?

Modbus is a serial communication protocol used for transmitting information over serial lines between electronic devices. The device requesting the information is called the Modbus Master and the devices supplying information are Modbus Slaves. In a standard Modbus network, there is one Master and up to 247 Slaves, each with a unique Slave Address from 1 to 247. The Master can also write information to Slaves.

Modbus has become a standard communication protocol in industry, and is now the most commonly available means of connecting industrial electronic devices. It is often used to connect a supervisory computer with a remote terminal unit (RTU) in supervisory control and data acquisition (SCADA)

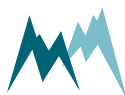

systems. Versions of the Modbus protocol exist for serial lines (Modbus RTU and Modbus ASCII) and for Ethernet (Modbus TCP).¹

13.5.2 What can I do with it?

Modbus-communication with SSG-2 allows reading of measurement values and device information by a Modbus master. Additionally, the basic RS-485 port settings can be written to the SSG-2.

13.5.3 Wiring

For Modbus communication the SSG-2 is wired according to the table below.

Modbus	Connector MAIN	Connection wire	Description
Common	Pin 1	White	GND
D1 - B/B	Pin 4	Yellow	RS-485 A
D0 - A/A	Pin 5	Grey	RS-485 B

Table 20 Modbus wiring



NOTE

Please note that different signal notations are in use for RS-485 connections:

TX+/RX+ or D+ or D1 as alternative for B

TX-/RX- or D- or D0 as alternative for A



NOTE If the SSG-2 is operated with multiple Modbus devices within the same network, termination resistors may be required. Please contact Sommer Messtechnik for details.

13.5.4 Modbus configuration

Follow the instructions below to change the communication of a Sommer Messtechnik device (in this example a RG-30) to Modbus:

¹<http://www.simplymodbus.ca/FAQ.htm>

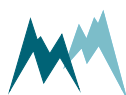

1. Connect the USB to RS-485 converter to the data cable of the Sommer Messtechnik device and a USB port on your PC.
2. Connect the sensor to a power supply with the specified rating.
3. Start the Commander software on your PC.
4. Establish a connection to the Sommer Messtechnik device.
5. Download the sensor's parameters in the **Parameters (F2)** tab and save the parameter list on your PC.



6. In the parameter list navigate to Technics and open the menu **RS485 (COM)** and take a screenshot of the associated parameters. This and the previous step are helpful if you need to switch back to the standard communication mode at a later time.

Parameters			
Main menu			
A	Measurement trigger	Interval	▼
B	Measurement interval	60	sec
▶	C DIG-OUT limit monitor		
▲	D Technics		
▶	A Units Expand		
▲	B SBP device addressing		
A	Device number	01	
B	System key	00	Expand
▲	C RS485 (COM)		
▲	A Output protocol		
A	Output protocol	Sommer	▼
B	Measurement output	After measurement	▼
C	Information	& Special values	▼
D	Wake-up sequence	Prefix	▼
E	Prefix holdback	300	ms
F	MODBUS, set default		
G	MODBUS, device address	35	Expand
▲	B Port		
A	Baudrate	9600	▼
B	Parity, stop bits	No par, 1 stop	▼
C	Minimum response time	10	ms
D	Transmitter warm-up time	10	ms
E	Flow control	Off	▼
F	Sending window	300	ms
G	Receiving window	300	ms
▶	D SDI12 Slave		
▶	E Additional settings		

7. Set **Measurement trigger** to one of the following options:
- Interval*, if measurements are triggered internally by the device.
 - SDI-12/RS-485*, if measurements are triggered by SDI-12.
 - TRIG input*, if measurements are triggered by a trigger input.
 - all allowed*, if measurements are triggered by one of the previous options.

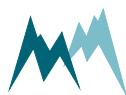



NOTE Modbus cannot trigger measurements! Make sure to use the trigger option suitable for your application!

- Verify that the connection to the Sommer Messtechnik device is active and click into the Terminal window. Type ??? to enter the sensor-menu.

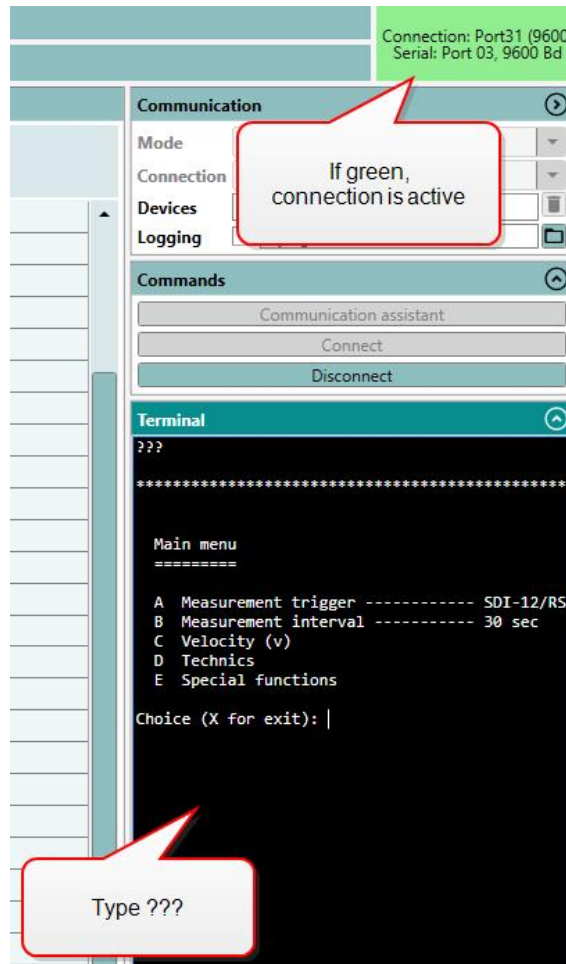

- Navigate to *RS485 protocol* and select *MODBUS, set default...* Please note, that the index-letters might be different for your Sommer Messtechnik device!

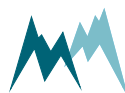

```

Terminal

Main menu
=====

A Measurement trigger ----- SDI-12/RS485
B Measurement interval ----- 30 sec
C Velocity (v)
D Technics
E Special functions

Choice (X for exit): d

Technics
=====

A Language/Sprache ----- english/englisch
B Decimal character ----- dot
C SDI-12 address ----- 1
D Channel type ----- open
E Advanced settings
F Tech. velocity (v)
G RS485 protocol
H RS485
I Units and decimals

Choice (X for exit): g

RS485 protocol
=====

A Device number
B System key --
C Output protocol
D Output (MO) t
E MO information
F MO wake-up se
G MO prefix holdback ----- 100 ms
H MODBUS, set default...
I MODBUS, device address ----- 35

Choice (X for exit):

```

Enter the letter of 'MODBUS, set default ...'

10. Acknowledge the safety-note.

```

Start up testmode: 0x09

MODBUS, set default
AAAAAAAAAAAAAAAAAAAA

PLEASE NOTE: This process changes to 19200 baud, even parity, ...
DIRECTIVE: Please don't forget to change the serial counterpart too!

Are you sure?

(Press "RETURN" to assume)
(Press "Esc" to cancel)

```

Press Enter

11. After completion the following message will be displayed:

```

=> Testmode finished!
=> DIRECTIVE: Please don't forget to change the serial counterpart too!

```

12. Enter X until you get back to the main menu. The Sommer Messtechnik device is now restarted and available for Modbus-communication. As the connection-parameters have been changed to Modbus, the connection to the sensor is lost. Press Disconnect for completion.

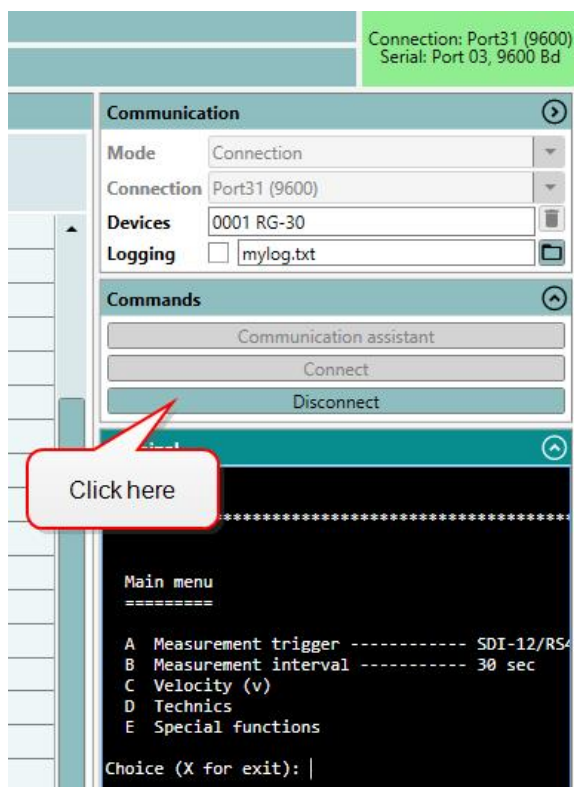

NOTE

By switching communication to Modbus with **MODBUS**, set default the following parameters are changed:

Parameter	Modbus setting
Measurement output	just per command
Output protocol	Modbus
MODBUS, device address	35
Sleep mode	Modbus, slow
Parity, stop bits	even par, 1 stop
Baudrate	19200
Flow control	off
Transmitter warm-up time	10 ms
Minimum response time	30 ms



TIP To change a parameter in the **Technics** menu you need to change your Commander-authorization to Expert. See [Change authorization](#) for instructions.

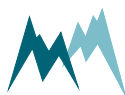

13.5.5 Modbus commands and registers

13.5.5.1 Read input registers

Input registers contain measurement values. The content of these registers is updated after each measurement.

	Index	Register address	Variable	Unit / value	Bytes	Format
Test value		0	Hardcoded test value	2.7519...	4	float
Main values	01	2	SWE	1	4	float
	02	4	Load cell temperature	°C/F		
	03	6	Ground temperature	°C/F		
	04	8	Error code	-		
Special values	05	10	Load cell 1	1	4	float
	06	12	Load cell 2	1		
	07	14	Load cell 3	1		
	08	16	Load cell 4	1		
	09	18	Error code int.	-		
	10	20	Internal temp.	°C/F		
	11	22	Supply voltage	V		
Device info	-	65533	Device type and configuration	3701	2	unsigned int
	-	65534	Software version	XYYZZ	2	
	-	65535	Modbus version	10100	2	

¹Unit according to Units.

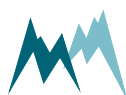

Table 21 Input registers



NOTE

The 4-byte float values have the format *ABCD*, big-endian (*A* is the most significant byte).

Note the difference between float, double and decimal data types. While float is a 4-byte floating-point-number, double is a 8-byte and decimal a 16-byte floating-point number. Use the applicable conversion to obtain the correct measurement values!

13.5.5.2 Read and write holding registers

Holding registers are mainly used to configure the Modbus adapter communication. Configuration settings are read with function 03 (read holding registers) and written with function 06 (write single registers).



NOTE Restart the Modbus adapter after changing the configuration!

	Register address	Variable	Range	Bytes	Format
Config values	0	Modbus default ¹	0 - 1...read 1...write	2	unsigned int
	1	Modbus device address	1 to 247		
	2	RS-485 baud rate	1...1200 baud 2...2400 baud 3...4800 baud 4...9600 baud 5...19200 baud 6...38400 baud 7...57600 baud 8...115200 baud		
	3	RS-485 parity/ stop bits	1...no parity, 1 stop bit 2...no parity, 2 stop bits 3...even parity, 1 stop bit 4...odd parity, 1 stop bit		

¹Writing "1" sets the Modbus default settings.



13.5.5.3 Report slave ID

The Modbus function 17 (report slave ID, read only) can be used to read basic information of the SSG-2. The following example shows the response of function 17 of a RG-30 sensor, which is received in hex-format:



```
EXAMPLE 23 11 26 53 FF 27 74 20 53 6F 6D 6D 65 72 20  
20 52 47 2D 33 30 20 20 20 32 5F 37 31 72 30 31 20 34  
35 31 35 31 38 32 31 00 BB D4
```

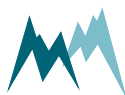

			Example	
	Content	Length (Bytes)	HEX-value	Decimal, ASCII
PDU* response	Slave address	1	23	35
	Function code	1	11	17
	Number of bytes (excl. slave-address, function code, NUL and CRC)	1	26	38
	Slave ID	1	53	"S"
	Run status (0=inactive; FF=active)	1	FF	255
	Modbus implementation version	2	27 74	10100
	Separator	1	20	" "
	Vendor string	7	53 6F 6D 6D 65 72 20	"Sommer "
	Separator	1	20	" "
	Device configuration	7	52 47 2D 33 30 20 20	"RG-30 "
	Separator	1	20	" "
	Software version	7	32 5F 37 31 72 30 31	2_71r01
	Separator	1	20	" "
	Serial number	8	34 35 31 35 31 38 32 31	45151821
	NUL	1	00	
	CRC	2	BB D4	

*Protocol Data Unit

Table 23 Slave ID

13.5.6 Reactivate Sommer Bus Protocol

Follow the instructions below to change the data output back to Sommer Bus Protocol:

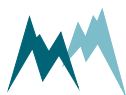

1. Open the **Connections (F8)** tab and click **New connection**.

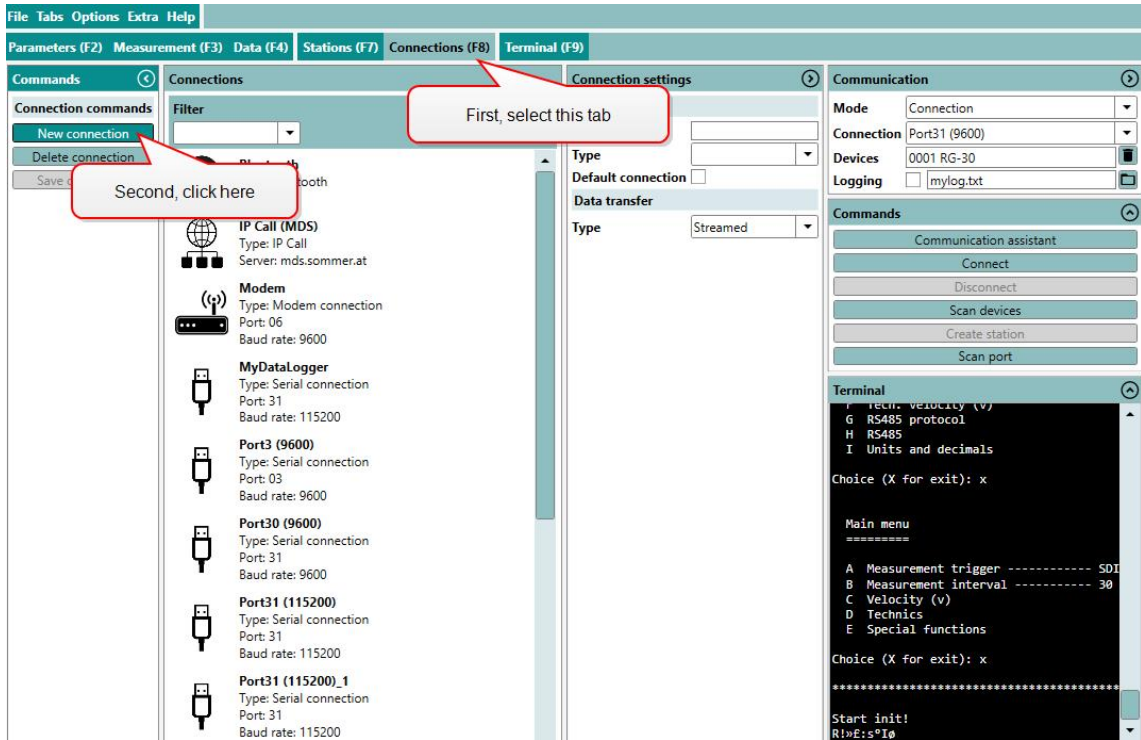

2. Enter the **Name** of the new connection. We recommend to use a meaningful name for later recognition, e.g. Modbus31 (19200) to indicate port 31 and Baud-rate 19200. Select the **Type** **Serial connection** and choose the **Port** your sensor is connected to, set the **Baud-rate** to **19200** and the **Parity/stop bits** to **Even par., 1 stop bit**.

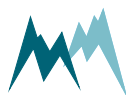

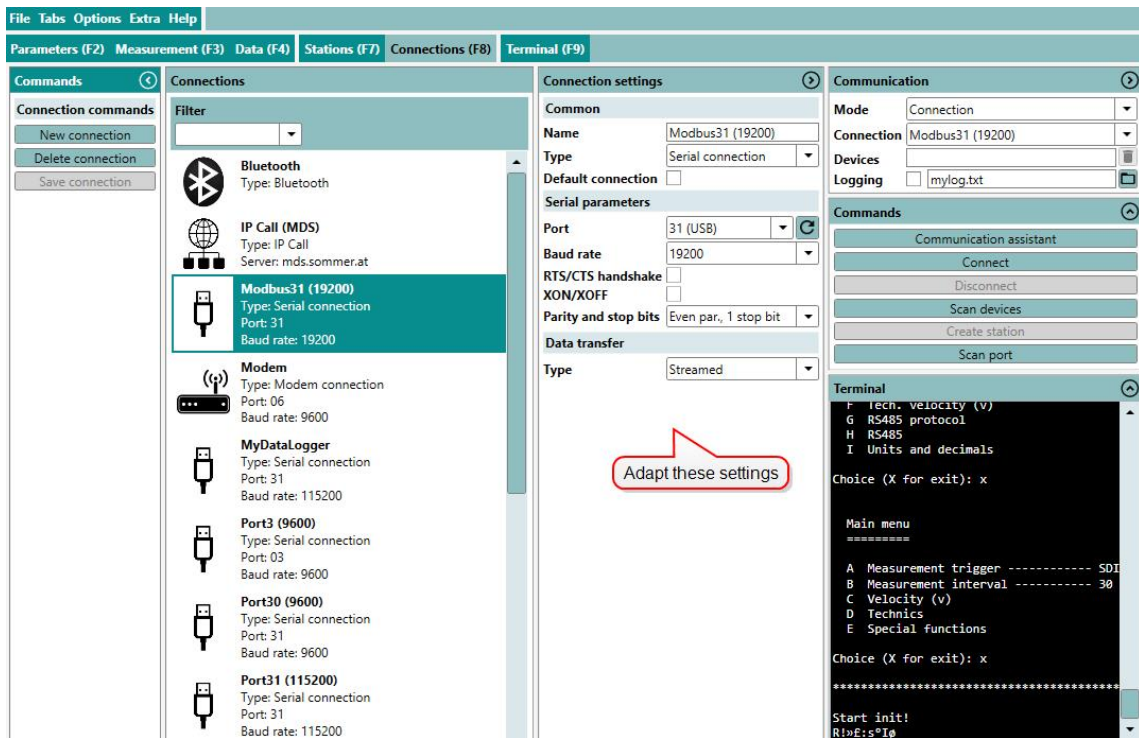

3. Click **Save connection**.
4. In the Communication window select **Mode Connection** and choose the **Connection** you have created. Then click **Connect**.

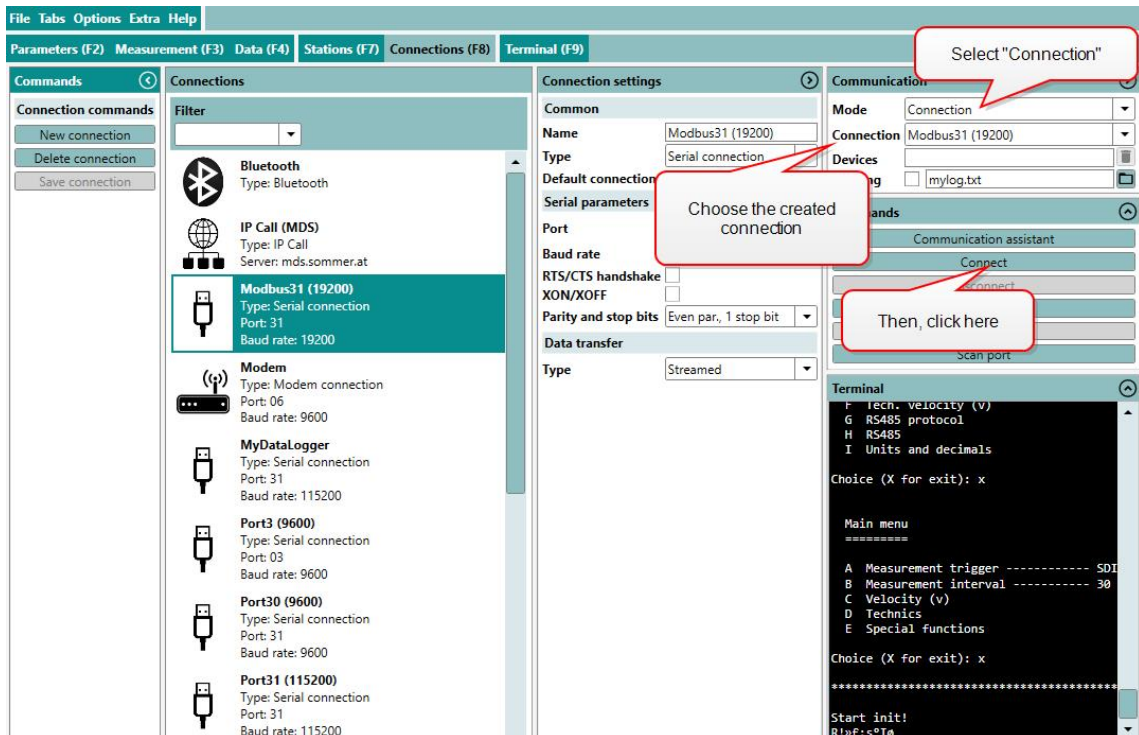

5. Download the parameters and save the parameter file as described in **Modbus configuration**.



TIP Save the parameter file for future use and to document configuration changes!

6. Now, two options are available to revert communication back to the Sommer Bus Protocol:

- A. If a parameter file is available that has the Sommer Bus Protocol enabled, the file can be loaded by clicking **Open parameter file**, selecting the respective file and uploading the parameters to the device by clicking **Upload all parameters to device**.

The screenshot displays the software interface with the 'Parameters' tab selected. The 'File commands' section is highlighted, showing the 'Open parameter file' and 'Upload all parameters to device' buttons. Red callout boxes point to these buttons with the text 'First, open the parameter file' and 'Second, upload parameters'. The 'Terminal' window shows a list of hex addresses and their corresponding commands.

- B. If no parameter file is available, the device has to be reset to its default configuration:

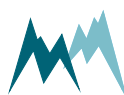

1. Click into the **Terminal** window and type ??? to enter the sensor-menu.

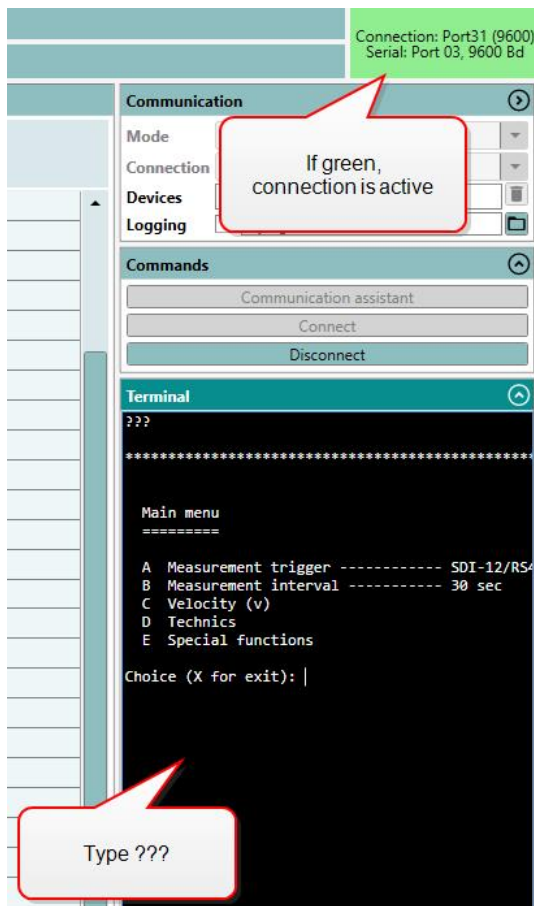

2. Navigate to **Special functions** and select **Set factory default...**
3. Acknowledge the safety-note.

```
Start up testmode: 0x07

Set factory default
^^^^^^^^^^^^^^^^^^

PLEASE NOTE: Please save all parameters before!
PLEASE NOTE: All user settings will be lost!
Are you sure?

(Press "RETURN" to assume)
(Press "Esc" to cancel)

=> Testmode finished!
```

4. Enter **X** until you get back to the main menu. The Sommer Messtechnik Sensor is now restarted and available in its initial configuration. As the connection-parameters have been changed to the default settings, the connection to the sensor is lost. Press **Disconnect** for completion.
7. Establish the original connection to the Sommer Messtechnik Sensor as described in **Modbus configuration**.

8. Download the sensor's parameters in the [Parameters \(F2\)](#) tab, adapt the required parameters, or upload your originally saved parameter file to the SSG-2.

13.5.7 PLC integration

The SSG-2 can be integrated into a PLC system as a slave device. It supports the PROFIBUS, PROFINET, EtherCAT and CANopen protocols. This requires an additional serial converter, e.g. Anybus Communicator.



14 Analog output

14.1 What can I do with it?

The SSG-2 offers the option to return the SWE as an analog 4...20 mA signal.

14.2 Activation

In the setting **Output status** the state of the analog output can be set to one of the following options:

ID	Option	Description
1	Off (default)	Analog outputs are inactive.
2	Just during TRIG	Analog outputs are only active, if an external signal is present at the TRIG input. The outputs are high as long as the signal at the TRIG input is high.
3	Always on	Analog outputs are permanently active.



NOTE The SSG-2 delays analog data acquisition by 200 ms. If **Output status** is set to *just during TRIG*, the analog output must be read with a delay of min. 200 ms after the trigger has been sent. This ensures that the analog measurement has sufficiently stabilized. As the analog measurement itself requires some time, the result should be read with a delay of *measurement duration + min. 1 second*.

14.3 Scaling

The variables and their analog output range are configured as described below.



NOTE The analog outputs may return currents between 0 and 21 mA. However, the accuracies stated in the specifications are only valid for signals within 4 to 20 mA!

If the measured value falls below or exceeds the 3.9...21 mA range, 3.9 mA and 21 mA, respectively, are returned. An exception are the measurement values



99999998 and 99999997, which return a 3.8-mA and 3.7-mA signal, respectively.



ATTENTION The 4-mA output should correspond to a measurement value at or below the expected minimum! With low current output the accuracy tends to decrease and cross-talk with other analog channels may occur.

14.4 IOOUT 1

The measured SWE can be returned as an analog 4...20 mA signal on pin 8 of the MAIN connector. The span and offset have to be configured in [4-20 mA outputs](#) to cover the range of the expected SWE.



EXAMPLE

In the default configuration the parameter `IOOUT1, SWE 4 mA value` is set to 0 and `IOOUT1, SWE 4-20 mA span to` 1'000 mmWC, 2'000 mmWC and 3'000 mmWC, respectively (see illustration below). Thus, an increase of 1 mA corresponds to an increase of 62,5 mmWC, 125 mmWC and 187.5 mmWC, respectively.

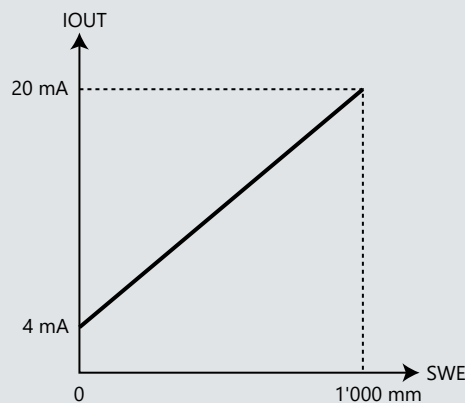

NOTE To verify the weight read by a data acquisition system with analog input, first perform a test as described in [Testing](#). Use the displayed value of the total weight to verify your analog reading.

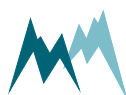

14.5 Simulate current output

With this function the analog outputs can be simulated. A user-defined current value between 4 and 20 mA is applied to the analog output pins, which can be read by a connected data acquisition device or multimeter. By pressing Return/Enter again the simulation stops.

14.6 Digital output

14.6.1 What can I do with it?

The provides a digital output indicating whether a specified SWE value is exceeded.

14.6.2 Configuration

Pin 7 of the SSG-2 MAIN connector provides a digital output to monitor a user defined SWE-limit. The output type and the threshold value can be configured in [DIG-OUT limit monitor](#).

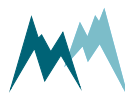

15 Parameter definitions

A	Measurement trigger	102
B	Measurement Interval	102
C	DIG-OUT limit monitor	103
D	Technics	104
E	Region format	119
F	Special functions	120
G	Measurement table	121

A Measurement trigger

`generic-measurement-trigger`

Measurements are initiated by one of the options listed in the table below.

The commands to trigger measurements via RS-485 and SDI-12 are described in [Communication](#).

Measured data are either returned directly after the measurement or can be requested by commands via the RS-485 or SDI-12 interface. The format of the returned data can be configured in the sub-menu [Output protocol](#).

ID	Option	Description
1	Interval (default)	Measurements are initiated in a specified interval.
2	TRIG input	Measurements are triggered by the positive edge of a DC-voltage signal applied to the TRIG input (low: 0 ... 0.6 V, high: 2.2 ... 28 V, pulse duration must be ≥ 500 ms, delay between pulses must be ≥ 500 ms)
3	SDI-12/RS-485	Measurements are externally triggered by commands via RS-485 or SDI-12 from ,e.g. a data logger.
4	all allowed	Measurement is triggered by all options mentioned above.

B Measurement Interval

`generic-measurement-interval`

An internal measurement interval can be set for the SSG-2. If selected in menu item [Measurement trigger](#), measurements are performed in the defined interval. However, a measurement is always completed before a new one is initiated.

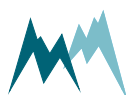

Value range	Default	Units
20...18'000	60	s

C DIG-OUT limit monitor

The SSG-2 supports surveillance of the snow water equivalent (SWE). If the SWE exceeds a specified value and **Limit monitor** is on DIG-OUT is set to high.

C-A	Limit monitor	103
C-B	Limit type	103
C-C	Limit value	103
C-D	Hysteresis	104

C-A Limit monitor

`generic-digital-out-limit-monitor`

Activates the Limit monitor (DIG-OUT).

ID	Parameter	Description
1	off (default)	Limit monitor is inactive
2	on	Limit monitor is active

C-B Limit type

`generic-digital-out-limit-type`

This parameter defines the orientation of the threshold. The following options are available:

ID	Parameter	Description
1	limit overrun (default)	Violation when the defined value exceeds the limit
2	limit underrun	Violation when the defined value drops below the limit

C-C Limit value

`generic-digital-out-limit-value`

The magnitude of the limit value.

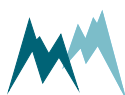

Value range	Default	Units
-99'999.99...999'999.99	100	Unit of variable

C-D Hysteresis

generic-digital-out-hysteresis

Setting a hysteresis value suppresses multiple violations if the measurement value closely fluctuates around the threshold. After a violation the output state is preserved until the measured value exceeds or falls below the specified hysteresis value. The hysteresis is an absolute value and is added with the correct sign to the threshold. The figure below illustrates an example.

Value range	Default	Units
0...999'999.99	2.00	Unit of variable

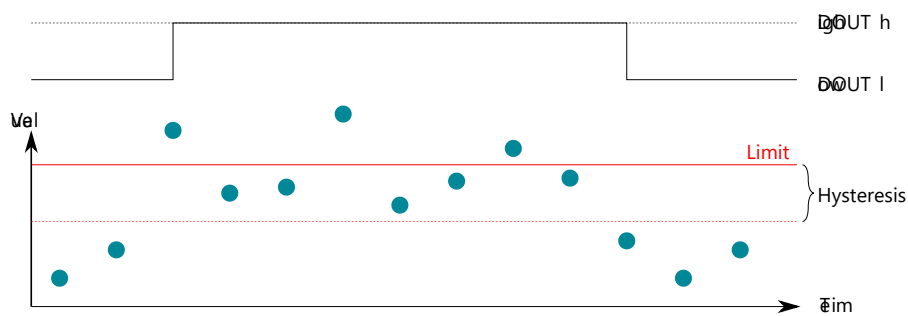

D Technics

D-A	Units	104
D-B	SBP device addressing	106
D-C	RS-485 (COM)	106
D-D	SDI-12 Slave	111
D-E	Additional settings	112
D-F	SSG calibration	113
D-G	SSG option, filter	114
D-H	Load cell analysis	116
D-I	Temperature	116
D-J	4-20 mA outputs	118

D-A Units

D-A-A	SWE	105
-------	-----------	-----

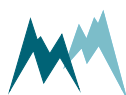

D-A-B	Weight	105
D-A-C	Temperature, unit	105

D-A-A SWE

generic-units-swe

The following units of the SWE (snow water equivalent) can be selected:

ID	Values	Description
1	kg/m ²	Kilograms per square meter
2	lb/ft ²	Pounds per square feet
3	mmWS	Millimeter Wassersäule
4	mmWC (default)	Millimeter water column
5	inWC	Inch water column

D-A-B Weight

generic-units-weight

The following units of the weight can be selected:

ID	Values	Description
1	kg (default)	Kilograms
2	lb	Pounds

D-A-C Temperature, unit

generic-units-temperature

The following units of the air temperature can be selected:

ID	Option	Description
1	°C (default)	Degrees Celsius
2	°F	Fahrenheit

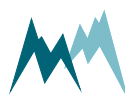

D-B SBP device addressing

D-B-A	Device number	106
D-B-B	System key	106

D-B-A Device number

`generic-rs-485-protocol-device-number`

The device number is used for the unique identification of the device in a bus system.

Value range	Default	Units
0...98	1 (default)	-

D-B-B System key

`generic-rs-485-protocol-system-key`

The system key defines the bus system of the device. Thus, different conceptual bus systems can be separated. Interfering bus systems occur if the remote radio coverage of two measurement systems overlap. In general, the system key should be set to 00.

Value range	Default	Units
0...99	0	-

D-C RS-485 (COM)

D-C-A	Output protocol	107
	D-C-A-A Output protocol	107
	D-C-A-B Measurement output	107
	D-C-A-C Information	107
	D-C-A-D Wake-up sequence	108
	D-C-A-E Prefix holdback	108
	D-C-A-F MODBUS, set default	108
	D-C-A-G MODBUS, device address	109
D-C-B	Port	109
	D-C-B-A Baudrate	109
	D-C-B-B Parity, stop bits	110
	D-C-B-C Minimum response time	110
	D-C-B-D Transmitter warm-up time	110
	D-C-B-E Flow control	111
	D-C-B-F Sending window	111
	D-C-B-G Receiving window	111

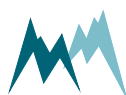

D-C-A Output protocol

D-C-A-A	Output protocol	107
D-C-A-B	Measurement output	107
D-C-A-C	Information	107
D-C-A-D	Wake-up sequence	108
D-C-A-E	Prefix holdback	108
D-C-A-F	MODBUS, set default	108
D-C-A-G	MODBUS, device address	109

D-C-A-A Output protocol

`generic-rs-485-protocol-output-protocol`

The type of the serial output protocol. The following options are available:

ID	Option	Description
1	Sommer (SBP) (default)	Sommer Bus Protocol; data values are returned with an index starting at 1. Multiple strings may be returned.
2	Standard	Standard protocol; data values are returned without an index in one string.
3	MODBUS	Modbus protocol



NOTE For MODBUS applications run `MODBUS, set default` to get the appropriate communication settings.

D-C-A-B Measurement output

`generic-rs-485-protocol-measurement-output`

Specifies the timing of the serial data output.

ID	Option	Description
1	Just per command	The output is only requested by commands via RS-485.
2	After measurement (default)	The serial data output is performed automatically right after each measurement.
3	Pos. TRIG slope	The output is triggered by a positive edge of a control signal applied to the trigger input.

D-C-A-C Information

`generic-rs-485-protocol-information`

The main measurement values are always included in the data output string. Additionally, special and analysis values can be included.

ID	Option	Description
1	Main values	Only the main values are returned.
2	& Special values (default)	Main values and special values are returned.
3	& Analysis values	Main, special and analysis values are returned.

D-C-A-D Wake-up sequence

`generic-rs-485-protocol-wake-up-sequence`

Serial data can be transmitted to a recording device automatically without a request. However, many devices demand a wake-up sequence before they can receive and process data. The SSG-2 has the option to send a sync sequence and a prefix before data are transmitted. The following options are available:

ID	Option	Description
1	Off	No wake-up sequence
2	Sync	The sync sequence UU~?~? is sent before the output string.
3	Prefix (default)	A blank with a time delay is sent before the output string.
4	Prefix & Sync	A blank with a time delay and the sync sequence UU~?~? is sent before the output string.

D-C-A-E Prefix holdback

`generic-rs-485-protocol-prefix-holdback`

The hold-back time defines the time delay between the prefix and the data string.

Value range	Default	Units
0...5'000	300	ms

D-C-A-F MODBUS, set default

`generic-rs-485-protocol-modbus-set-default`



Sets all parameters required for Modbus communication automatically. The following settings are adapted:

Parameter	Modbus setting
Measurement output	just per command
Output protocol	Modbus
MODBUS, device address	35
Sleep mode	Modbus, slow
Parity, stop bits	even par, 1 stop
Baudrate	19200
Flow control	off
Transmitter warm-up time	10 ms
Minimum response time	30 ms

D-C-A-G MODBUS, device address

`generic-rs-485-protocol-modbus-device-address`

Unique device address for the Modbus protocol.

Value range	Default	Units
1...247	35	-

D-C-B Port

D-C-B-A	Baudrate	109
D-C-B-B	Parity, stop bits	110
D-C-B-C	Minimum response time	110
D-C-B-D	Transmitter warm-up time	110
D-C-B-E	Flow control	111
D-C-B-F	Sending window	111
D-C-B-G	Receiving window	111

D-C-B-A Baudrate

`generic-rs-485-port-baud-rate`

The following transmission rates in bps (baud) can be selected:

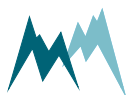

ID	Option	Description
1	1'200	-
2	2'400	-
3	4'800	-
4	9'600 (default for sensors and data logger inputs)	-
5	19'200 (default if used with radio communication)	-
6	38'400	-
7	57'600	-
8	115'200 (default for data loggers)	-

D-C-B-B Parity, stop bits

```
generic-rs-485-port-parity-stop-bits
```

The following combinations of parity and stop bits can be selected:

ID	Option	Description
1	No par, 1 stop (default)	No parity and 1 stop bit
2	No par, 2 stop	No parity and 2 stop bits
3	Even par, 1 stop	Even parity and 1 stop bit
4	Odd par, 1 stop	Odd parity and 1 stop bit

D-C-B-C Minimum response time

```
generic-rs-485-port-minimum-response-time
```

This setting avoids failures of half-duplex interfaces. For this purpose the response to a command is delayed by the selected time. Additionally, the response is also kept temporally compact.

Value range	Default	Units
0...2'000	10	ms

D-C-B-D Transmitter warm-up time

```
generic-rs-485-port-transmitter-warm-up-time
```

The transmitter warm-up time defines the time before data is sent.

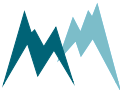

Value range	Default	Units
0...2'000	10	ms

D-C-B-E Flow control

`generic-rs-485-port-flow-control`

Flow control for the defined application.

ID	Option	Description
1	Off	no flow control
2	XOFF-XON blocking (default)	XOFF-XON flow control, especially adapted for half-duplex systems
4	DFM-RC	Flowcontrol for Sommer Messtechnik DFM point-to-point radios.
5	DFM-TM	Flowcontrol for Sommer Messtechnik DFM tiny-mesh radios.

D-C-B-F Sending window

`generic-rs-485-port-sending-window`

If XON-XOFF flow control is activated data are transmitted in blocks with the defined length.

Value range	Default	Units
200...5'000	300	ms

D-C-B-G Receiving window

`generic-rs-485-port-receiving-window`

If XON-XOFF flow control is activated transmission of blocks is delayed by the specified time.

Value range	Default	Units
200...5'000	300	ms

D-D SDI-12 Slave

D-D-A	SDI-12 address	112
D-D-B	SDI12 Information	112

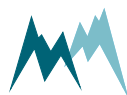

D-D-A SDI-12 address

generic-sdi-12-address

The address is a unique identifier of the sensor within a SDI-12 bus system.

Value range	Default	Units
0...9, a...z, A...Z	0	-

D-D-B SDI12 Information

generic-sdi-12-information

The scope of the data output.

ID	Parameter	Description
1	main values (default)	Only main values are returned.
2	& special values	Main values and special values are returned.
3	& analysis values	Main, special and analysis values are returned.

D-E Additional settings

D-E-A	Sleep mode	112
D-E-B	Sommer ID	113

D-E-A Sleep mode

generic-sleep-mode

Defines the behavior of the SSG-2 between two measurements, provided the measurement interval is longer than the time of the measurement itself. The following options are available:

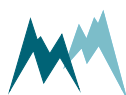

ID	Option	Description
1	MODBUS, fast	For MODBUS applications. The SSG-2 stays in normal mode. This option permits high data transmission rates, but increases power consumption.
2	MODBUS, slow	For MODBUS applications. The SSG-2 goes into idle mode and can be woken up by a command via the RS-485 interface with a low baud rate. This option reduces power consumption at lower data transmission rates.
3	Standard (default)	The SSG-2 goes into sleep mode and can be woken up by a command via the RS-485 interface only with a time delay. Option with the lowest power consumption.

D-E-B Sommer ID

`generic-sommer-id`

The Sommer ID is used to define stations within the Commander software. The ID is preset in the device and corresponds to its serial number. SOMMER suggests not to change the ID, except if a SSG-2 device is replaced. In such a case it can be practical to change the ID of the new device to the ID of the replaced device to guarantee data consistency.

D-F SSG calibration

D-F-A	SSG test	113
D-F-B	Set zero	113
D-F-C	Set span, weight	114
D-F-D	Set span, SWE	114
D-F-E	Edit zero & gain	114

D-F-A SSG test

Function to test the weight and SWE measured by the SSG-2. It returns the weight and error code.

D-F-B Set zero

Function to set the zero-point. The SSG-2 must not be loaded when running this function. Follow the instructions displayed during the procedure.

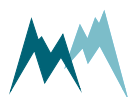

D-F-C Set span, weight

Optional. Function to set the span in terms of weight. Follow the instructions displayed during the procedure.



ATTENTION As the span determines the gain of the load cells any error in span measurement may alter SWE-results significantly. Only use standardized loads with a weight near the maximum expected SWE to determine the span.

D-F-D Set span, SWE

Optional. Function to set the span in terms of SWE. Follow the instructions displayed during the procedure.



ATTENTION As the span determines the gain of the load cells any error in span measurement may alter SWE-results significantly. Only use standardized loads with a weight near the maximum expected SWE to determine the span.

D-F-E Edit zero & gain

A list where zero and gain values of the four load cells can be adjusted individually.

D-G SSG option, filter

D-G-A	Filter, no of values	114
D-G-B	Filter, type	115
D-G-C	SWE algorithm	115
D-G-D	Deactivation limits	115
	D-G-D-A Temperature limit	116
	D-G-D-B Weight limit	116
	D-G-D-C Load cell difference limit	116

D-G-A Filter, no of values

Every SWE measurement is stored internally in a buffer for filtering. This setting defines the number of measurement values in the buffer. If the buffer is full, the oldest value is replaced by the most recent value.

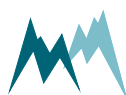

Value range	1...30	Number of values used for filtering.
Default	1	No filter is applied.

D-G-B Filter, type

The SWE values in the buffer can be filtered by one of the following options:

Parameter	Description
moving average (default)	The mean value of all buffered values is calculated.
median value	The median value of the buffered data is returned.
elim. all spikes	To eliminate spikes the mean value is calculated without the 5 highest and 5 lowest buffered values. If the buffer size is smaller than 15 two third of the values are eliminated.

D-G-C SWE algorithm

The algorithm by which the SWE is calculated. The following options are available:

Parameter	Description
SA-Standard	Standard algorithm
DA-Dynamic	Dynamic algorithm
DAA-Dynamic (default)	Dynamic average algorithm



ATTENTION For calibration and test with a reference weight, the **SWE algorithm** must be set to SA-Standard!

D-G-D Deactivation limits

The limits specified here determine the measurement state of the SSG-2.

D-G-D-A	Temperature limit	116
D-G-D-B	Weight limit	116
D-G-D-C	Load cell difference limit	116

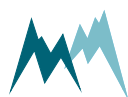

D-G-D-A Temperature limit

Above this temperature, the SSG-2 will not measure the SWE anymore and returns zero.

Unit	Unit of temperature	
Value range	-150...300	10 °C (default)

D-G-D-B Weight limit

The SSG-2 will start measuring again, regardless of the temperature limit, when the weight limit is exceeded. This might be useful to detect if any object, e.g. a branch, has dropped on the SSG-2 during summer.

Unit	Unit of weight	
Value range	0...999.9	5.0 (default)

D-G-D-C Load cell difference limit

The maximum difference of the weight measured by two load cells. If the error limit is exceeded by one or two cells, the SWE is calculated from the other cells only. If this parameter is set to 0, the Load cells error limit is deactivated.

Unit	Unit of weight	
Value range	0...999.9	
Special function	0 (default)	Limit is deactivated

D-H Load cell analysis

Function to test the load cells. The SSG-2 performs a measurement and returns the raw values of weight, bridge voltage, supply voltage and offset.

D-I Temperature

D-I-A	Ground temperature	117
D-I-B	Load cell temperature offset	117
D-I-C	Ground temperature offset	117
D-I-D	Test sensor temperatures	117
D-I-E	Adjust sensor temperatures	118

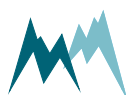

D-I-A Ground temperature

Enables you to monitor ground temperature. Use this menu to manage the sensor, including turning it on or off.

ID	Parameter	Description
1	off (default)	Sensor is switched off
2	on	Enables the sensor

D-I-B Load cell temperature offset

Offset of the load cell temperature. An offset might be required if the sensor needs to be matched to an external reference. Can also be set with the function [Adjust sensor temperatures](#).

Unit	Unit of temperature	
Value range	-9999.99...99999.99	0.00 (default)

D-I-C Ground temperature offset

Offset of the ground temperature. An offset might be required if the sensor needs to be matched to an external reference. Can also be set with the function [Adjust sensor temperatures](#). Applicable if ground temperature sensor is connected and turned on (optional, needs to be installed by Sommer GmbH).

Unit	Unit of temperature	
Value range	-9999.99...99999.99	0.00 (default)

D-I-D Test sensor temperatures

Function to test the Load cell temperature.

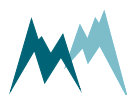

D-I-E Adjust sensor temperatures

Function to adjust the temperature measurements of the SSG-2. Applying this function will update the settings [Load cell temperature offset](#) and [Ground temperature offset](#). Follow the instructions displayed during the procedure.

D-J 4-20 mA outputs

D-J-A	Output status	118
D-J-B	IOUT1, SWE 4-20 mA span	118
D-J-C	IOUT1, SWE 4 mA value	119
D-J-D	Simulate current output	119

D-J-A Output status

`generic-analog-out-status`

The status defines the behavior of the analog outputs.

ID	Option	Description
1	Off (default)	Analog outputs are inactive.
2	Just during TRIG	Analog outputs are only active, if an external signal is present at the TRIG input. The outputs are high as long as the signal at the TRIG input is high.
3	Always on	Analog outputs are permanently active.

D-J-B IOUT1, SWE 4-20 mA span

Defines the output range of the 4-20 mA signal of IOUT1. The span should cover the expected SWE range.

Unit	Unit of SWE	
Value range	-9'999'999...99'999'999	1'000 (default SSG-2 1000) 2'000 (default SSG-2 2000) 3'000 (default SSG-2 3000)

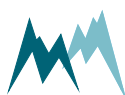

D-J-C IOUT1, SWE 4 mA value

Defines the minimum SWE that corresponds to the 4 mA current output. Usually, this value is zero.

Unit	Unit of SWE	
Value range	-9'999'999...99'999'999	0 (default)

D-J-D Simulate current output

`generic-analog-out-simulate-current`

With this function the analog outputs can be simulated. Upon submission of a current value between 4 and 20 mA the corresponding values of the selected variable are displayed. The selected current is also applied to the active analog outputs and can be read with a connected data logger or multimeter. By pressing Return/Enter again the simulation stops.



NOTE

If **Output status** is deactivated, no current output can be simulated.

If **Output status** is set to **just during TRIG**, the trigger must be set prior to simulation. Additionally, the trigger must be reset before each simulation.

E Region format

E-A	Language/Sprache	119
E-B	Decimal character	120

E-A Language/Sprache

`generic-language`

The menu language.

ID	Option	Description
1	German/Deutsch	German language
2	English/Englisch (default)	English language

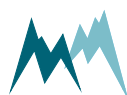

E-B Decimal character

generic-decimals-character

The character used as decimal separator in the values of the settings, in serial data strings and in .csv files.

ID	Option	Description
1	Comma	-
2	Dot (default)	-

F Special functions

F-A	Device status	120
F-B	View setup	120
F-C	Continuous meas. mode (temp).	120
F-D	Set factory default	121
F-E	Temp. load factory default	121
F-F	Relaunch program	121

F-A Device status

generic-special-functions-device-status

Displays information about the device and the software version.

F-B View setup

generic-special-functions-view-setup

All parameters of the SSG-2 are listed in the terminal window.

F-C Continuous meas. mode (temp).

generic-special-functions-continuous-meas-mode

Inactive in the Commander menu. This feature can be triggered in the Commander under the **Measurement (F3)** tab with the command **Start polling measurements** and then **Start polling WITH measurements**. When active, measurements are performed continuously, ignoring the specified measurement interval.

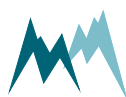

F-D Set factory default

`generic-special-functions-set-factory-default`

All parameters are reset to factory defaults. Only available in terminal-mode.

F-E Temp. load factory default

`generic-special-functions-temp-load-factory-default`

Loads factory default values temporarily. Only available in terminal mode.

F-F Relaunch program

`generic-special-functions-relaunch-program`

The device is restarted. Powering the device off and on again is equivalent.

G Measurement table

`generic-measurement-table`

Adjustment

`generic-measurement-table-adjustment`

A measurement of the selected variable is triggered and the result displayed in a terminal window. If the measured value deviates from the correct value, the correct value can be entered. This adjusts the value in **Offset**. The factor in **Scale** is not affected by this correction.



Appendix A Troubleshooting

A.1	Devices	122
A.1.1	The SSG-2 is not responding or returns unreadable characters	122
A.1.2	The SSG-2 reboots repeatedly	124
A.2	Measurement data	124
A.2.1	Measurement data are not updated	124
A.2.2	The SSG-2 reads zero weights	124
A.3	Firmware & software	124
A.3.1	Commander loads wrong setup	124
A.3.2	Firmware update via RS-485 is aborted	125
A.4	SDI-12	125
A.4.1	The SSG-2 is not detected by a SDI-12 master device	125
A.5	Analog output	126
A.5.1	The 4-20 mA output is wrong	126

A.1 Devices

A.1.1 The SSG-2 is not responding or returns unreadable characters

Reason	Solution
The power supply is not connected or turned off.	Check if the power supply is connected and on.
The polarity of connected power supply wires is wrong.	Check the polarity of connected wires.
Wrong sensor cable.	Use the original sensor cable configured by Sommer Messtechnik (only applicable to Sommer Messtechnik cables).
Power supply is insufficient. The SSG-2 requires a certain inrush-current that the power supply is not able to provide.	<ol style="list-style-type: none"> 1. Use a power supply providing >0.5 A at 12 VDC or a fully charged battery. 2. In case of long sensor cables (>50 m) use a 24-VDC power supply. Please note that power supplied by the USB-port is insufficient to power the SSG-2!
The power supply voltage is out of range.	Adjust the power supply to match the specified voltage range.
The polarity of the connected RS-485-A and RS-485-B wires is wrong.	Reverse the polarity of the connected RS-485-A and RS-485-B wires.

Reason	Solution
The port settings of the SSG-2 and the data acquisition system do not match.	<p>Use the Commander Communication assistant or adapt port settings on your device.</p> <p> NOTE Sommer Messtechnik devices require the following Baudrates:</p> <ul style="list-style-type: none"> ■ Sensor: 9600 ■ Data logger: 115200 ■ Modbus: 19200 <p>In case of doubt use the function Check port in the Communication assistant.</p>
The SSG-2 is set to Modbus.	Connect to the sensor using the Communication assistant of the Commander and select the Modbus option in the Serial connection .
A sensor wire is not connected firmly to the terminal of the data acquisition device.	Check the firm connection of the sensor wires.
SSG-2 and data acquisition device have different grounds.	Connect the grounds of the SSG-2 and the data acquisition device.
A pin of the connector plug is bent or broken.	Verify that all connector pins are straight.
The sensor cable is damaged.	Replace the sensor cable.
The COM-port has not been assigned correctly to the USB converter.	<ol style="list-style-type: none"> 1. Make sure to use a Sommer Messtechnik USB converter. Third party converters are not supported. 2. Check the COM-port number using Windows Device Manager. 3. Plug in the USB converter first, then start Commander.
The USB converter is faulty.	Replace the USB converter.
The USB port on your PC is not working.	Use another USB port.
The driver of the USB converter was incorrectly installed	Reinstall the driver of the USB converter.

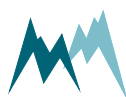

A.1.2 The SSG-2 reboots repeatedly

Reason	Solution
The power supply has not enough current to start the SSG-2.	Verify that the power supply provides enough current. A SSG-2 consumes up to 140 mA @ 12 V. If required, power the SSG-2 by an additional or alternative supply.

A.2 Measurement data

A.2.1 Measurement data are not updated

The device is connected to the Commander, but the data are not updated.

Reason	Solution
Data traffic conflict	Reboot the device by interrupting the power supply.

A.2.2 The SSG-2 reads zero weights

Cause	Solution
A deactivation limit is set	Reduce Weight limit to a lower value or zero.

A.3 Firmware & software

A.3.1 Commander loads wrong setup

If the setup is reloaded from the device the Commander seems to display an old version.

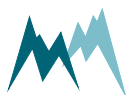

Cause	Solution
The device has been connected to the same PC before and several different setup files have been loaded.	<ul style="list-style-type: none"> ■ In the Communication section of the Commander, select Mode Connection and click on the trash can icon on the right edge. Then, reload the setup from the device. ■ Delete the setup files of the device that have been downloaded by Commander to the folder <code>C:\Users\Public\Documents\Sommer\Setup</code>. The respective files can be identified by the serial number in the file name and the file date.

A.3.2 Firmware update via RS-485 is aborted

Reason	Solution
USB to RS-485 converter cable is damaged or can only operate on 9600 baud.	Replace USB to RS-485 converter cable. The programmer requires 57600 baud.

A.4 SDI-12

A.4.1 The SSG-2 is not detected by a SDI-12 master device

Reason	Solution
The SSG-2 and the SDI-12 master have different grounds.	Verify that the SSG-2 and the SDI-12 master are connected by a ground (GND) wire.



A.5 Analog output

A.5.1 The 4-20 mA output is wrong

Reason	Solution
Analog output settings incorrect.	<ol style="list-style-type: none"> 1. Check analog output settings. 2. Run Simulate current output and verify the correct output.
Sensor and data acquisition system have different grounds.	Verify that sensor and data acquisition system have the same ground.
The analog output is read by a data acquisition system and the scaling is wrong.	Verify scale and offset on your data acquisition system.
Two or more analog outputs of the SSG-2 are read by a data acquisition system and the wiring is wrong, e.g. IOUT1 is read as IOUT2.	Verify the wiring on your data acquisition system and swap the wires if required.
The 4-20 mA output is delayed by approx. 150 ms. If the output is read before, a wrong value is acquired.	Sample the 4-20 mA output with a delay of more than 150 ms.

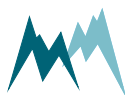

Appendix B CRC-16 array

CRC-16 array

```
1  crc16tab[] =
2  {
3  0x0000, 0x1021, 0x2042, 0x3063, 0x4084, 0x50A5, 0x60C6, 0x70E7,
4  0x8108, 0x9129, 0xA14A, 0xB16B, 0xC18C, 0xD1AD, 0xE1CE, 0xF1EF,
5  0x1231, 0x0210, 0x3273, 0x2252, 0x52B5, 0x4294, 0x72F7, 0x62D6,
6  0x9339, 0x8318, 0xB37B, 0xA35A, 0xD3BD, 0xC39C, 0xF3FF, 0xE3DE,
7  0x2462, 0x3443, 0x0420, 0x1401, 0x64E6, 0x74C7, 0x44A4, 0x5485,
8  0xA56A, 0xB54B, 0x8528, 0x9509, 0xE5EE, 0xF5CF, 0xC5AC, 0xD58D,
9  0x3653, 0x2672, 0x1611, 0x0630, 0x76D7, 0x66F6, 0x5695, 0x46B4,
10 0xB75B, 0xA77A, 0x9719, 0x8738, 0xF7DF, 0xE7FE, 0xD79D, 0xC7BC,
11 0x48C4, 0x58E5, 0x6886, 0x78A7, 0x0840, 0x1861, 0x2802, 0x3823,
12 0xC9CC, 0xD9ED, 0xE98E, 0xF9AF, 0x8948, 0x9969, 0xA90A, 0xB92B,
13 0x5AF5, 0x4AD4, 0x7AB7, 0x6A96, 0x1A71, 0x0A50, 0x3A33, 0x2A12,
14 0xDBFD, 0xCBDC, 0xFBBF, 0xEB9E, 0x9B79, 0x8B58, 0xBB3B, 0xAB1A,
15 0x6CA6, 0x7C87, 0x4CE4, 0x5CC5, 0x2C22, 0x3C03, 0x0C60, 0x1C41,
16 0xEDAE, 0xFD8F, 0xCDEC, 0xDDCD, 0xAD2A, 0xBD0B, 0x8D68, 0x9D49,
17 0x7E97, 0x6EB6, 0x5ED5, 0x4EF4, 0x3E13, 0x2E32, 0x1E51, 0x0E70,
18 0xFF9F, 0xEFBE, 0xDFDD, 0xCFFC, 0xBF1B, 0xAF3A, 0x9F59, 0x8F78,
19 0x9188, 0x81A9, 0xB1CA, 0xA1EB, 0xD10C, 0xC12D, 0xF14E, 0xE16F,
20 0x1080, 0x00A1, 0x30C2, 0x20E3, 0x5004, 0x4025, 0x7046, 0x6067,
21 0x83B9, 0x9398, 0xA3FB, 0xB3DA, 0xC33D, 0xD31C, 0xE37F, 0xF35E,
22 0x02B1, 0x1290, 0x22F3, 0x32D2, 0x4235, 0x5214, 0x6277, 0x7256,
23 0xB5EA, 0xA5CB, 0x95A8, 0x8589, 0xF56E, 0xE54F, 0xD52C, 0xC50D,
24 0x34E2, 0x24C3, 0x14A0, 0x0481, 0x7466, 0x6447, 0x5424, 0x4405,
25 0xA7DB, 0xB7FA, 0x8799, 0x97B8, 0xE75F, 0xF77E, 0xC71D, 0xD73C,
26 0x26D3, 0x36F2, 0x0691, 0x16B0, 0x6657, 0x7676, 0x4615, 0x5634,
27 0xD94C, 0xC96D, 0xF90E, 0xE92F, 0x99C8, 0x89E9, 0xB98A, 0xA9AB,
28 0x5844, 0x4865, 0x7806, 0x6827, 0x18C0, 0x08E1, 0x3882, 0x28A3,
29 0xCB7D, 0xDB5C, 0xEB3F, 0xFB1E, 0x8BF9, 0x9BD8, 0xABBB, 0xBB9A,
30 0x4A75, 0x5A54, 0x6A37, 0x7A16, 0x0AF1, 0x1AD0, 0x2AB3, 0x3A92,
31 0xFD2E, 0xED0F, 0xDD6C, 0xCD4D, 0xBDAA, 0xAD8B, 0x9DE8, 0x8DC9,
32 0x7C26, 0x6C07, 0x5C64, 0x4C45, 0x3CA2, 0x2C83, 0x1CE0, 0x0CC1,
33 0xEF1F, 0xFF3E, 0xCF5D, 0xDF7C, 0xAF9B, 0xBFBA, 0x8FD9, 0x9FF8,
34 0x6E17, 0x7E36, 0x4E55, 0x5E74, 0x2E93, 0x3EB2, 0x0ED1, 0x1EF0
35 }
```

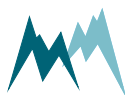

Glossary

A

ablation

removal of material from the surface of an object by vaporization, chipping, or other erosive processes. In this case the opposite of snow accumulation.

B

blowing snow

an ensemble of snow particles raised by the wind to moderate or great heights above the ground; the horizontal visibility at eye level is generally very poor NOTE See also drifting snow

D

drifting snow

snow raised from the snow surface by the wind to a height of less than 2 metres; it does not restrict horizontal visibility at 2 metres or more above the surface NOTE See also blowing snow

F

firn

well-bonded and compacted snow that has survived the summer season, but has not been transformed to glacier ice NOTE Typical densities

are 400 - 830 kg·m⁻³. Thus, firn is the intermediate stage between snow and glacial ice where the pore space is at least partially interconnected. Firn usually results from both melt-freeze cycles and compaction by overload, or from compaction alone, as in inland Antarctic snow.

fractional snow cover

the areal extent of snow-covered ground in relation to the total catchment, usually expressed as % of total area in a given region

G

gliding snow

slow, gliding motion of the snowpack over smooth or wet ground, e.g. grassy slopes or smooth rock slabs, attaining velocities of a few millimetres to a few metres per day

I

IP-Call

A technology that provides communication services over the Internet.

M

Modbus

A serial communications protocol for connecting industrial electronic

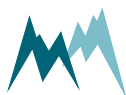

devices.

N

new snow

recently fallen snow in which the original form of the ice crystals can be recognized NOTE New snow can be measured by use of a snow board

P

perennial snow

snow persisting for an indefinite time longer than one year NOTE See also seasonal snow and firn

R

RS-485

A standard defining the signal transmission in serial communication systems.

S

SBP

Sommer Bus Protocol

SDI-12

Asynchronous serial communications protocol for intelligent sensors (Serial Digital Interface at 1200 baud)

seasonal snow

snow that accumulates during, and lasts, for only one season NOTE See also perennial snow.

snow accumulation

opposite of ablation all processes that add mass to the snow cover, i.e. typically solid and liquid precipitation, ice deposition from atmospheric water vapor, and snow deposited by wind, avalanches, etc.

snow avalanche

mass of snow which becomes detached and slides swiftly down a slope NOTE Large snow avalanches may contain rocks, soil, vegetation, and/or ice

snow board

a specially constructed board used to measure new snow manually

snow course

an established line, or transect, of measurements of SWE across a snow-covered area in a representative terrain, where snow accumulation is not homogeneously distributed in the terrain

snow cover

the accumulation of snow on the ground the areal extent of snow-covered ground NOTE See also snowpack, and fractional snow cover.

snow creep

a continuous, slow downhill movement of a snow layer

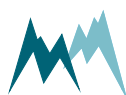

snow crust

a crisp, firm, outer surface upon snow NOTE Basically, three types of snow crusts exist, formed by 1) the refreezing of surface snow, after melting and/or wetting, which forms a hard layer of snow (sun crust, rain crust, spring crust); 2) the packing of snow into a hard layer by wind action (wind crust, wind slab); and 3) a continuous layer of ice on top of snow formed by freezing of surface water (film crust, ice crust). A snow crust is designated as "breakable" or "unbreakable" according to its ability to support a person on skis.

snow density

the mass of snow per unit of volume NOTE Sometimes total and dry snow densities are measured separately. Total snow density encompasses all constituents of snow (ice, liquid water, and air) while dry snow density refers to the ice matrix and air only.

snow depth

the total height of the snowpack measured vertically from the base to the snow surface NOTE The slope-perpendicular equivalent of snow depth is the snow thickness

snow distribution

spatial and temporal variability of snow cover affected by snowfall, wind speed, elevation, topography, vegetation and ablation

snow height

the vertical distance from a base to a specific level in the snow, or to the snow surface NOTE Ground surface is usually taken as the base, but on firn fields and glaciers it refers to the level of either the firn surface or glacier ice. Height is used to denote the position of different snow layers but also of measurements such as snow temperatures relative to the base. In those cases, where only the upper half of the snowpack gets analyzed, the snow surface may be taken as the reference. This should be indicated by using negative coordinate values. Snow depth is the total height of the snowpack.

snow layer

a layer of ice crystals with similar size and shape, delimited by two clear layer boundaries

snow load

the downward force on an object or structure caused by the weight of accumulated snow

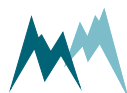

snow pit

a pit dug vertically into the snowpack where snowpack stratigraphy and characteristics of individual snow layers are observed
NOTE See also snow profile

snow profile

a stratigraphic record of the snowpack including characteristics of individual snow layers, usually performed in snow pits

snow redistribution

distribution of previously deposited snow that was eroded and transported by the wind
NOTE Redistribution features such as snowdrifts are usually formed from densely packed and friable snow

snow stake

instrument for making manual measurements of the snow depth

snow survey

the process of determining snow parameters, most often depth and density, at representative points, usually along a snow course

snow thickness

the snowpack measured slope-perpendicularly from the base to the snow surface
NOTE See also snow depth

snow water equivalent (SWE)

water equivalent of snow cover term expressing the depth of water that would be obtained by melting the snowpack in a given area
NOTE The snow water equivalent can represent the snow cover over a given region or a confined snow sample over the corresponding area. It is the product of the snow depth and the snow density divided by the density of water, and is typically expressed in millimetres of water equivalent, which is equivalent to kilograms per square metre or litres of water per square metre.

snowmelt

the change of the physical state of snowpack from solid to liquid phase, mainly affected by various meteorological factors (e.g. temperature, air humidity, radiation, wind, rain etc.)

snowpack

the accumulation of snow on the ground at a given site and time. It often consists of various layers with different physical and mechanical properties
NOTE See also snow cover

solid precipitation

the solid products of the condensation of water vapor falling from clouds or deposited from air

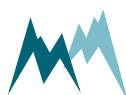

on the ground as snow, snow pellets, snow grains, ice pellets, hoarfrost, rime and hail

