

# RQ-30+

Contact-free Discharge Measurement System

## Manual

Setup version 2.48.05 (Firmware 4.05)

06.09.2024



Sommer Messtechnik

All rights reserved.

The Copyrights for this manual are exclusively owned by

Sommer Messtechnik  
6842 Koblach  
Austria

This manual or parts of it may only be copied or passed on to third parties with written permission of Sommer Messtechnik. This applies to printed as well as digital issues of this manual.



Sommer Messtechnik  
Strassenhäuser 27  
6842 Koblach  
Austria  
[www.sommer.at](http://www.sommer.at)  
E [office@sommer.at](mailto:office@sommer.at)  
T +43 5523 55989  
F +43 5523 55989-19

## Validity

This manual applies to the Contact-free Discharge Measurement System with the setup version 2.48.05, including all its subversions.

Created: 30.08.2024

Last update: 06.09.2024

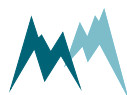

# EU conformity



This product is in conformity with the following standards:

EMC	2014/30/EU	EN 301 489-1 V1.9.2
EMC	2014/30/EU	EN 61326-1:2013
		EN 55022:2010
LVD	2014/35/EU	EN 62311:2008
		EN 62368-1:2014
RED	2014/53/EU	EN 300 440-2 V1.4.1
Machinery directive	2006/42/CE	
RoHS II	2011/65/EU	EN 50581:2012
RoHS III	2015/863/EU	
REACH	1907/2006/EU	



## FCC compliance



This device complies with Part 15 of the FCC Rules. Operation is subject to the following two conditions: (1) This device may not cause harmful interference, and (2) This device must accept any interference received, including interference that may cause undesired operation.

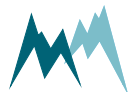

# FCC and IC compliance

This device complies with Part 15 of the FCC Rules and with Industry Canada license-exempt RSS standard(s). Operation is subject to the following two conditions:

1. this device may not cause harmful interference, and
2. this device must accept any interference received, including interference that may cause undesired operation.

Le présent appareil est conforme aux CNR d'Industrie Canada applicables aux appareils radio exempts de licence. L'exploitation est autorisée aux deux conditions suivantes:

1. l'appareil ne doit pas produire de brouillage, et
2. l'appareil doit accepter tout brouillage radioélectrique subi, même si le brouillage est susceptible d'en compromettre le fonctionnement.

Changes or modifications made to this equipment not expressly approved by Sommer Messtechnik may void the FCC authorization to operate this equipment.

NOTE: This equipment has been tested and found to comply with the limits for a Class A digital device, pursuant to Part 15 of the FCC Rules. These limits are designed to provide reasonable protection against harmful interference when the equipment is operated in a commercial environment. This equipment generates, uses, and can radiate radio frequency energy and, if not installed and used in accordance with the instruction manual, may cause harmful interference to radio communications. Operation of this equipment in a residential area is likely to cause harmful interference in which case the user will be required to correct the interference at his own expense.

**ISED Certification Number: 25742-RGSENS**

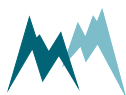

# Safety information

Please read this manual carefully before installing or operating this equipment. Non-compliance with the instructions given in this manual can result in failure or damage of the equipment or may put people at risk by injuries through electrical or mechanic impact.

- Make sure that the personnel responsible for installation, configuration and maintenance is familiar with the applicable regulations and standards!
- Installation of equipment on towers, bridges and in discharge channels poses the risk of falling, slipping or dropping of objects. Contact your safety officer or consult applicable safety regulations for precautions and proper personal safety equipment.
- Do not perform any installations in bad weather conditions, e.g. thunderstorms.
- Prior to installation of equipment inform the owner of the measurement site or the authority responsible for it. Upon completion, secure the installation from trespassers.
- Maintenance and repair must be performed by trained personnel or an engineer of Sommer Messtechnik. Only replacement parts supplied by Sommer Messtechnik should be used for repairs.
- Make sure that NO power is connected to the equipment during installation and wiring!
- Only use a power supply that complies with the power rating specified for this equipment!
- Keep equipment dry during wiring and maintenance!
- If applicable, it is recommended to use accessories of Sommer Messtechnik with this equipment.

## Disposal



After this device has reached the end of its lifetime, it must not be disposed of with household waste! Instead, dispose of the device by returning it to a designated collection point for the recycling of waste electrical and electronic equipment.



## Feedback

Should you come across any error in this manual, or if you miss information to handle and operate the RQ-30+ we are pleased to receive your feedback to [office@sommer.at](mailto:office@sommer.at).

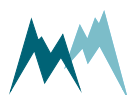

# Content

- 1 What is the RQ-30+? .....16
- 2 Unpacking ..... 18
- 3 Get started ..... 19
  - 3.1 Connect the RQ-30+ to your PC ..... 19
  - 3.2 Configure the RQ-30+ ..... 20
  - 3.3 Adjust the RQ-30+ to the current water level ..... 20
  - 3.4 Acquire measurements ..... 20
- 4 How the RQ-30+ works ..... 22
  - 4.1 Water level ..... 22
    - 4.1.1 Definition ..... 22
    - 4.1.2 Principle of measurement ..... 23
  - 4.2 Flow velocity ..... 23
    - 4.2.1 Principle of measurement ..... 23
    - 4.2.2 Flow direction separation ..... 24
    - 4.2.3 Inclination angle measurement ..... 24
    - 4.2.4 Conditions of the water surface ..... 24
    - 4.2.5 Radar spectrum ..... 25
  - 4.3 Determination of water discharge ..... 26
    - 4.3.1 Base equation ..... 26
    - 4.3.2 k-Factors ..... 26
    - 4.3.3 Cross-Sectional area ..... 27
    - 4.3.4 Discharge calculation ..... 27
- 5 Components ..... 28
  - 5.1 RQ-30+ device ..... 28
    - 5.1.1 Velocity sensor ..... 28
    - 5.1.2 Level sensor ..... 28
    - 5.1.3 Main connector ..... 28
    - 5.1.4 Connector LEVEL ..... 29
- 6 Specifications ..... 30
- 7 Installation ..... 32
  - 7.1 Site selection ..... 32
    - 7.1.1 Hydraulic requirements ..... 32
    - 7.1.2 Installation requirements ..... 34
    - 7.1.3 Documentation ..... 35
  - 7.2 Performing a site survey ..... 35
  - 7.3 Things to consider for installation ..... 40
    - 7.3.1 Power supply ..... 40

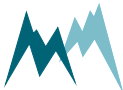

7.3.2	Signal cables .....	40
7.3.3	Lightning protection .....	41
7.4	Required tools and equipment .....	41
7.5	Mounting .....	41
7.6	Wiring .....	42
7.6.1	RS-485 wiring .....	42
7.6.2	SDI-12 wiring .....	43
7.6.3	How to wire analog outputs .....	44
7.7	Adjustment of water level .....	45
7.8	Start-up .....	45
8	Operation .....	46
8.1	Connect device to PC .....	46
9	Maintenance .....	47
9.1	Device status .....	47
10	Support software Q-Commander .....	57
10.1	Software features .....	57
10.2	System requirements .....	57
10.3	Installation of Q-Commander .....	57
10.4	Change authorization .....	62
10.5	Working with connections .....	63
10.5.1	Establish a connection with the Communication assistant .....	63
10.5.2	Establish a connection manually .....	63
10.5.3	Create a new connection .....	63
10.6	Working with stations .....	64
10.6.1	Create a station with the Communication assistant .....	64
10.6.2	Create a station manually .....	68
10.7	Working with measurements .....	69
10.7.1	Poll continuous measurements .....	69
10.7.2	Record measurements .....	70
10.8	Working with data .....	70
10.8.1	View live data .....	70
10.9	Working with spectra .....	71
10.9.1	Record spectrum .....	71
10.9.2	Read spectrum file .....	72
10.10	Working with setups .....	72
10.10.1	Download setup .....	72
10.10.2	Open a setup file .....	72
10.10.3	Edit setup .....	73
10.10.4	Upload new setup file .....	73

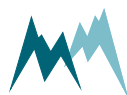

10.11 Update firmware .....	73
11 Configuration of the RQ-30+ .....	76
11.1 Software tools .....	76
11.2 Configuration with Q-Commander support software .....	76
11.3 Configuration with a terminal program .....	79
11.4 Conflict messages .....	80
11.4.1 Setup conflicts .....	80
11.5 General settings .....	81
11.5.1 Measurement trigger .....	81
11.5.2 Language/Sprache .....	82
11.5.3 Decimal character .....	82
11.5.4 Units and decimals .....	82
11.5.5 Protocol type .....	82
11.5.6 Information .....	83
11.6 Water level measurement .....	83
11.6.1 WMA, maximum level .....	83
11.6.2 WLL, low level border .....	84
11.6.3 WCF, cease to flow level .....	84
11.6.4 Adjustment .....	84
11.7 Velocity measurement .....	86
11.7.1 Viewing direction .....	86
11.7.2 Possible flow directions .....	86
11.7.3 Measurement duration .....	87
11.7.4 Minimum velocity .....	87
11.7.5 Maximum velocity .....	87
11.7.6 Meas. spot optimization .....	87
11.7.7 Measurement type .....	87
11.7.8 Criteria for invalid measurements and their handling .....	87
11.7.9 Inclination measurement .....	88
11.7.10 View spectral distribution .....	88
11.8 Discharge table .....	88
11.9 Total discharge volume .....	88
11.10 W-v relation .....	88
11.10.1 Usage .....	89
11.10.2 Learning of the W-v relation .....	89
11.10.3 Water levels for the W-v relation .....	90
11.10.4 Activation .....	90
11.10.5 W-v priority .....	90
11.10.6 W-v table reset .....	90

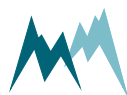

12	Communication .....	91
12.1	Communication protocols .....	91
12.2	Data output .....	91
12.2.1	Main values .....	91
12.2.2	Special values .....	92
12.2.3	Analysis values .....	92
12.2.4	Quality value .....	93
12.2.5	Exception values .....	94
12.3	RS-485 .....	94
12.3.1	What is RS-485? .....	94
12.3.2	What can I do with it? .....	94
12.3.3	Configuration .....	94
12.3.4	Data output options .....	96
12.3.5	Sommer Bus Protocol (SBP) .....	96
12.3.6	Standard protocol .....	100
12.3.7	Sommer old protocol .....	103
12.3.8	RS-485 commands .....	103
12.3.9	Sommer Messtechnik CRC-16 .....	106
12.4	SDI-12 .....	107
12.4.1	What is SDI-12? .....	107
12.4.2	What can I do with it? .....	108
12.4.3	Configuration .....	108
12.4.4	Data structure .....	108
12.4.5	SDI-12 commands .....	109
12.5	Modbus .....	113
12.5.1	What is Modbus? .....	113
12.5.2	What can I do with it? .....	114
12.5.3	Wiring .....	114
12.5.4	Modbus configuration .....	115
12.5.5	Modbus commands and registers .....	120
12.5.6	Reactivate Sommer Bus Protocol .....	123
12.5.7	PLC integration .....	129
13	Analog output .....	130
13.1	What can I do with it? .....	130
13.2	Activation .....	130
13.3	Scaling .....	130
13.3.1	IOOUT1 – AUX .....	131
13.3.2	IOOUT2 – water level .....	131
13.3.3	IOOUT3 – flow velocity .....	132



13.3.4	IOUT4 – discharge .....	133
13.4	Simulate current output .....	133
14	Parameter definitions .....	134
A	Measurement trigger .....	134
B	Measurement Interval .....	134
C	AUX .....	135
C-A	Mean value, no. of values .....	135
C-B	Test .....	136
C-C	Adjustment .....	136
D	Level (W) .....	136
D-A	Mean value, no. of values .....	136
D-B	Test .....	137
D-C	Adjustment .....	137
D-D	W_Q, fixation level .....	137
D-E	WMA, maximum level .....	138
D-F	WLL, low level border .....	138
D-G	WCF, cease to flow level .....	138
D-H	W-v table reset .....	139
E	Velocity .....	139
E-A	Viewing direction .....	139
E-B	Possible flow directions .....	140
E-C	River inclination .....	140
E-D	Yaw angle .....	141
E-E	Measurement duration .....	141
E-F	Filter, no. of values .....	141
E-G	Filter, type .....	142
F	Discharge table .....	143
F-A	Status .....	143
F-B	Level (W) .....	144
F-C	k value .....	144
F-D	Area (A) .....	144
G	DIG OUT .....	145
G-A	LM, trigger via .....	145
G-B	LM, limit type .....	145
G-C	LM, limit value .....	145
G-D	LM, hysteresis .....	146
H	Technics .....	146
H-A	SDI-12 address .....	147
H-B	Channel type .....	147



H-C	W-v priority .....	147
H-D	Area correction .....	148
H-E	Units and decimals .....	148
	H-E-A AUX unit .....	148
	H-E-B AUX decimals .....	148
	H-E-C Level, unit .....	149
	H-E-D Level, decimals .....	149
	H-E-E Velocity, unit .....	149
	H-E-F Velocity decimals .....	150
	H-E-G Discharge (Q), unit .....	150
	H-E-H Discharge (Q) decimals .....	151
	H-E-I Total discharge volume unit* .....	151
	H-E-J Total discharge volume decimal .....	151
	H-E-K Simulation, discharge volume .....	152
	H-E-L Area (A), unit .....	154
	H-E-M Area (A) decimals .....	154
H-F	SBP device addressing .....	155
	H-F-A Device number .....	155
	H-F-B System key .....	155
H-G	RS-485 (COM) .....	155
	H-G-A Output protocol .....	156
	H-G-A-A Protocol type .....	156
	H-G-A-B Measurement output .....	156
	H-G-A-C Information .....	157
	H-G-A-D Wake-up sequence .....	157
	H-G-A-E Prefix holdback .....	158
	H-G-A-F MODBUS, set default .....	158
	H-G-A-G MODBUS, device address .....	158
	H-G-B Port .....	158
	H-G-B-A Baud rate .....	159
	H-G-B-B Parity, stop bits .....	159
	H-G-B-C Minimum response time .....	159
	H-G-B-D Transmitter warm-up time .....	160
	H-G-B-E Flow control .....	160
	H-G-B-F Sending window .....	160
	H-G-B-G Receiving window .....	160
H-H	Advanced settings .....	161
	H-H-A Reset general behavior .....	161
	H-H-B Reset total discharge volume .....	161

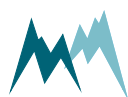

	H-H-C	Inclination measurement	162
	H-H-D	Sleep mode	162
	H-H-E	Sommer ID	162
H-I		Tech. AUX	163
	H-I-A	Status	163
	H-I-B	Supply	163
	H-I-C	Warm-up time	164
	H-I-D	0-2.5 V input span	164
	H-I-E	0 V input value	164
H-J		Tech. level (W)	164
	H-J-A	Supply	164
	H-J-B	Warm-up time	165
H-K		Tech. velocity (v)	165
	H-K-A	Minimum velocity	166
	H-K-B	Maximum velocity	166
	H-K-C	Meas. spot optimization	166
	H-K-D	Measurement type	168
	H-K-E	Stop, min. quality (SNR)	169
	H-K-F	Stop, max. opp. direction	169
	H-K-G	Stop, number of valid meas.	169
	H-K-H	Stop, behavior	170
	H-K-I	Stop, replace value	171
	H-K-J	Start velocity at WLL	171
	H-K-K	Velocity output	171
	H-K-L	Meas. spot weighting	171
H-L		4-20 mA outputs	172
	H-L-A	Output status	172
	H-L-B	IOOUT1, AUX 4-20 mA span	172
	H-L-C	IOOUT1, AUX 4 mA value	173
	H-L-D	IOOUT2, level 4-20 mA span	173
	H-L-E	IOOUT2, level 4 mA value	173
	H-L-F	IOOUT3, Max. velocity	174
	H-L-G	IOOUT4, max. discharge	174
	H-L-H	Simulate current output	174
I		Region format	175
	I-A	Language/Sprache	175
	I-B	Decimal character	175
J		Special functions	175
	J-A	View spectral distribution	176

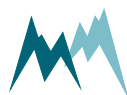

J-B	Veloc. radar inspection (Som)	176
J-C	Veloc. radar inspection (RFB)	176
J-D	Continuous meas. mode (temp).	176
J-E	View spectral trap	176
J-F	View setup	177
J-G	Device status	177
J-H	W-v table view	177
J-I	W-v table reset	177
J-J	Set factory default	177
J-K	Temp. load factory default	178
J-L	Relaunch program	178
J-M	Replace program	178
15	Replacement parts	179
Appendix A	Troubleshooting	181
A.1	Devices	181
A.1.1	The RQ-30+ is not responding or returns unreadable characters	181
A.1.2	The RQ-30+ reboots repeatedly	183
A.2	Measurement data	183
A.2.1	Measurement data are not updated	183
A.2.2	The RQ-30+ returns no or zero velocity	184
A.2.3	The RQ-30+ returns negative velocities	184
A.2.4	The RQ-30+ returns the wrong water level	185
A.2.5	The RQ-30+ continuously returns the same water level	185
A.2.6	The RQ-30+ returns no water discharge	186
A.2.7	The measured discharge is too low or too high	186
A.2.8	The RQ-30+ returns negative discharge values	187
A.2.9	The discharge sum is reset regularly	188
A.2.10	Learned velocity and discharge are inconsistent	188
A.2.11	Quality values are low or negative	188
A.2.12	Velocity/level data show spikes	189
A.2.13	W-v table reset fails	189
A.3	Firmware & software	189
A.3.1	Commander loads wrong setup	189
A.3.2	Firmware update via RS-485 is aborted	190
A.4	RS-485	190
A.4.1	Configuration via terminal shows unexpected behavior	190
A.5	SDI-12	190
A.5.1	The RQ-30+ is not detected by a SDI-12 master device	190

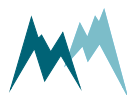

A.6	Modbus .....	191
A.6.1	Modbus function 04 returns obscure measurement values .....	191
A.7	Analog output .....	192
A.7.1	The 4-20 mA output is wrong .....	192
Appendix B	Unwanted reflections .....	193
B.1	Open channel .....	193
B.2	Closed channel .....	194
2.3	Examples of velocity spectra .....	195
Appendix C	CRC-16 array .....	199

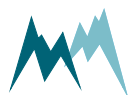

# 1 What is the RQ-30+?

The exact and real time knowledge of water discharge is of central importance in the fields of hydrography, water storage management, irrigation and for the early detection of floods. It is essential in hydraulic engineering and water resource management and is the basis for hydrological modelling and simulation.

The RQ-30+ sensor is a continuous measurement device for the contact-free determination of the water discharge of open rivers and channels. It combines two sensors in one system. The first determines the water level by measuring the transit time of a radar signal. The second simultaneously measures the flow velocity of the water surface by means of the Doppler frequency shift. These two measurements are internally combined and thus provide the water discharge by using an advanced hydraulic model from Sommer Messtechnik to calculate the discharge in real-time inside the RQ-30+.

Due to the contact-free measurement method the RQ-30+ can be installed on extension arms or cable ways without costly structural measures under or inside the water. This also has the advantage that the sensor is located outside the danger area of flood events and that it requires no maintenance over many years.

Harnessing the Power of AI and Machine Learning for Precision Measurements and Unmatched Reliability.

Unlocking new frontiers in data accuracy, the RQ-30+ integrates cutting-edge internal AI and machine learning algorithms, ensuring unparalleled precision even in challenging environmental conditions.

Distinguished by its exceptional robustness, the RQ-30+ stands tall as the instrument of choice, trusted and deployed across thousands of sites spanning over 120 countries worldwide.

Not just a technological marvel, the RQ-30+ is also eco-conscious, boasting low-power consumption and seamlessly operating on solar power, making it a sustainable solution for tomorrow's needs.

Experience the future of measurement technology with the RQ-30+: Where innovation meets reliability, and precision knows no bounds.



## FEATURES

- Contact-free radar method prevents soiling and damage, no sensor maintenance
- Automatic discharge calculation based on hydraulic model with multiple dyn. k-factors.
- Sensor self check with status and error output.
- AI-based machine learning for compensation of environmental influences and early detection of errors.
- 3-point velocity calibration certificate.
- Advanced velocity diagnostics with spectrum display
- Discharge calculation inside the RQ-30+.

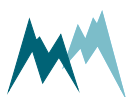



- Water level and velocity sensor combined in one weather and vandalism proof housing.
- Sommer Messtechnik ANR: advanced noise reduction system

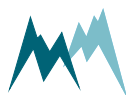
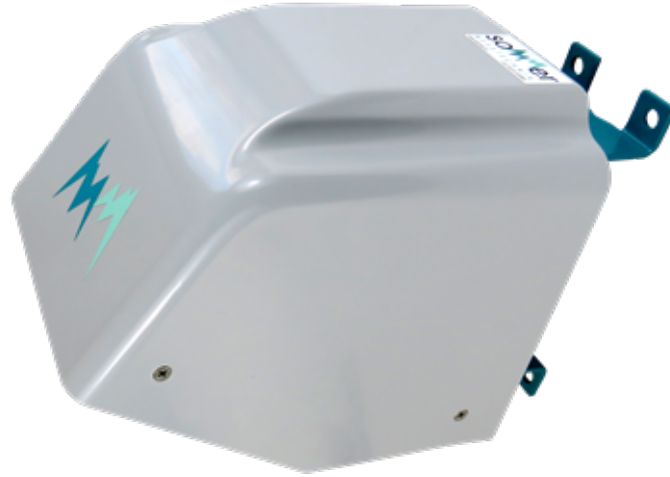

## 2 Unpacking

When unpacking your RQ-30+ sensor box please make sure that the following items are present:

Qty	Art	Item
1	-	RQ-30+ in the required version
1	-	Manual and Q-Commander Software on USB stick

In case of missing or damaged items please contact your Sommer Messtechnik sales partner.

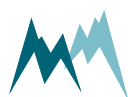

## 3 Get started

Follow the steps described below to set the basic configurations and to acquire the first measurement results.



**NOTE** Perform the first start-up in your lab or office before installing the equipment in the field!

### 3.1 Connect the RQ-30+ to your PC

1. Install the Q-Commander support software (see [Installation of Q-Commander](#) )
2. Connect the yellow and gray wires of the sensor cable to the RS-485 to USB converter cable and plug it into your PC as illustrated in the figure below.
3. Connect a 9...30 VDC power supply to the RQ-30+.
4. Click on [Communication assistant](#) on the right-hand side of the Q-Commander window and follow the instructions. During this procedure the communication assistant will search for connected devices. Upon successful completion, the new connection is added to the connections list (tab [Connections \(F8\)](#)).
5. In the [Communication](#) Section at the right-hand side of the Q-Commander window select Mode [Connection](#) and the previously created connection from the drop-down list.
6. Click [Connect](#) to establish a connection with the RQ-30+. If the connection was successful a green icon is displayed at the top-right corner of the Q-Commander window.
7. Select the tab [Parameters \(F2\)](#) and click [Download parameters from device](#) on the left side of the Q-Commander window. The complete parameter list is transferred from the sensor to your PC and displayed in the [Parameter](#) window.

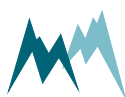
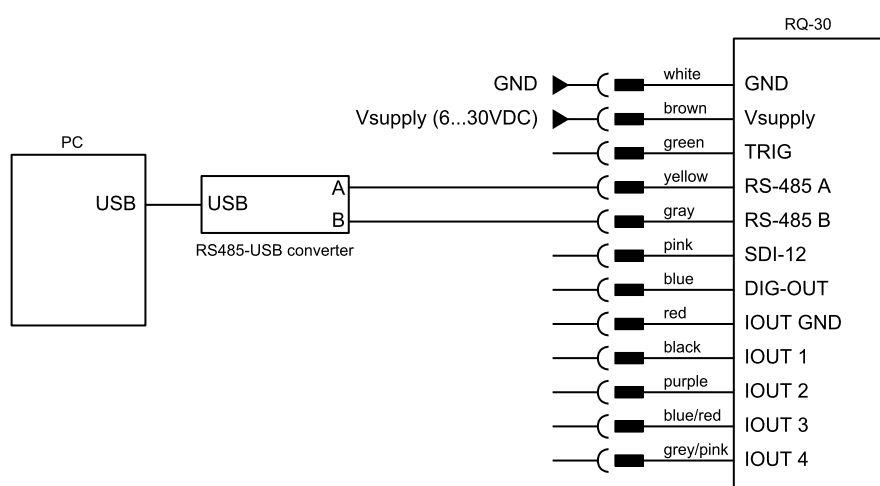

## 3.2 Configure the RQ-30+

1. Select language, decimal character, units and decimal places (see [General settings](#))
2. Select the measurement trigger (see [General settings](#))
3. Set the parameters of the water level measurement (see [Water level measurement](#))
4. Set the parameters of the velocity measurement (see [Velocity measurement](#))
5. Transfer the discharge table from the Q-Commander to the RQ-30+ sensor (see [Discharge table](#))
6. Optional: Configure analog outputs (see [Scaling](#))
7. Send any modifications to the RQ-30+ by clicking [Upload modified parameters to device](#).

## 3.3 Adjust the RQ-30+ to the current water level

This step needs to be performed as soon as the RQ-30+ has been installed at its final location. The respective procedure is described in [Adjustment of water level](#).

## 3.4 Acquire measurements



**ATTENTION** Do not start the RQ-30+ while the target surface is within the blanking distance of the level sensor! Otherwise the RQ-30+ will not receive level measurements for several minutes! See for the blanking distance of your sensor.

1. Establish a connection to your device as described in [Working with connections](#).
2. Download the setup of your device as described in [Download setup](#).
3. Select the [Measurement \(F3\)](#) tab.
4. In the [Commands](#) section click [Start polling measurement](#). Now, the Q-Commander will trigger measurements of the RQ-30+ without any delays between measurements. The results are displayed [Measurement values](#) and plotted in the [Measurement data graph](#).

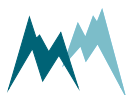

- To finish polling mode click **Stop polling**.

The screenshot displays the M1 Commander 2.0.1.0 software interface. The main window is titled 'Measurement (F)' and shows various data points and a graph. A red callout box highlights the 'Start and stop polling' button in the 'Polling commands' section. Another red callout box points to the 'Last measurement' row in the 'Measurement values' table. The graph at the bottom shows a red line representing 'Flow sum [m³/h]' over time.

ID	Name	Value	Unit
0	Self-check	0	
1	Level	40	mm
2	Velocity	1.023	m/s
3	Quality (SH)	87.01	
4	Flow	5.143	m³/h
5	Flow sum	m³/h	
6	Learned velocity	1.023	m/s
7	Learned flow	5.143	m³/h

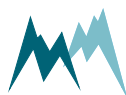

## 4 How the RQ-30+ works

The RQ-30+ measures the water level contact-free with distance sensor and the flow velocity of the water surface with a Doppler radar sensor and calculates the water discharge.

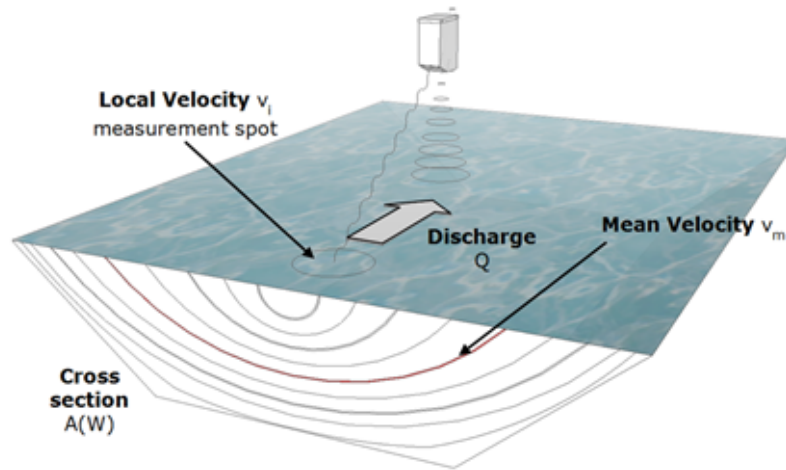

Figure 1 Principle of measurement of the RQ-30+ sensor

### 4.1 Water level

#### 4.1.1 Definition

The water level  $W$  is the vertical distance of a point of the water surface above or below a reference level defined, e.g., by the deepest point of the cross-sectional profile, sea level or gauge zero (GZ).

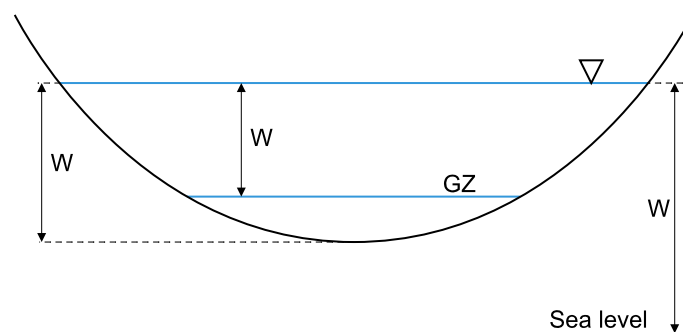

Figure 2 Water level  $W$  and gauge zero GZ

## 4.1.2 Principle of measurement

The water level sensor is installed above a river or channel and transmits a short signal towards the water surface. This signal is reflected at the water surface and recorded by the sensor now working as a receiver. The traveling time of the impulse is directly proportional to the distance between the sensor and the water surface.

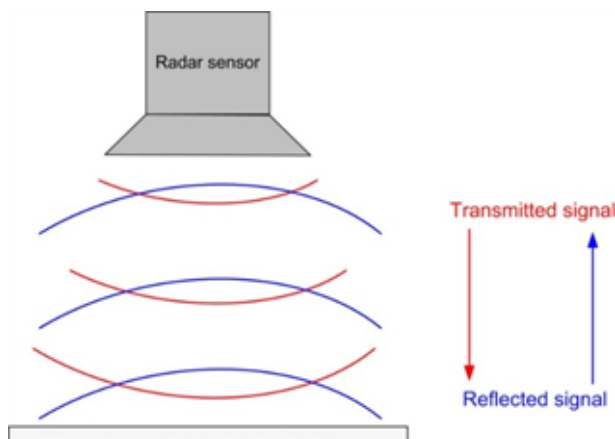

Figure 3 Principle of water level sensor

## 4.2 Flow velocity

### 4.2.1 Principle of measurement

The contact-free measurement of the flow velocity is based on the principle of the Doppler Effect. The integrated velocity radar sensor transmits a signal with a constant frequency in a specific angle towards the water surface (see Figure 4). There, the signal is reflected and shifted in frequency due to the movement of the water body. The reflected signal is received by the antenna of the integrated velocity radar sensor. By comparing the emitted frequency to the frequency of the reflected signal from the water surface the local velocity can be determined.

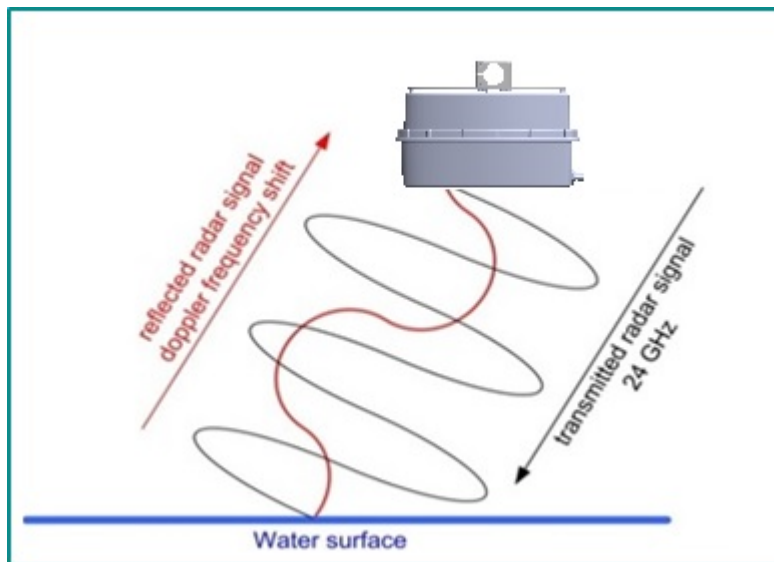

Figure 4 Principle of flow velocity sensor

#### 4.2.2 Flow direction separation

Water can either flow towards or away from the integrated velocity radar sensor. Depending on the flow direction a frequency shift to higher or lower frequencies occurs. This circumstance allows the RQ-30+ sensor to separate the water movements by their directions and to separately evaluate the corresponding velocity distribution.

#### 4.2.3 Inclination angle measurement

As the RQ-30+ sensor is directed in a specific angle towards the water surface an angle correction has to be applied. The RQ-30+ measures its vertical inclination with an internal sensor and applies an automatic angle correction.

#### 4.2.4 Conditions of the water surface

The water surface has to move distinctly and a minimum roughness has to be present to measure a discernible Doppler frequency shift. The more rippled the water surface and the higher the flow velocity is the more reliable the measurements are. The minimum ripple height for a valid analysis is about 2 mm depending on the used frequency. For very slow moving rivers this requirement might not be fulfilled and a continuous and correct velocity measurement cannot be guaranteed.

## 4.2.5 Radar spectrum

The integrated velocity radar sensor has an opening angle of  $12^\circ$ . Thus, the reflected radar signal of an area is measured. The size of this area depends on the inclination angle and the distance between the sensor and the reflecting water surface.

The velocities appearing in the measured area have a specific distribution depending on the water flow conditions. The velocity distribution is determined with a digital signal processor via spectral analysis, and the dominant velocity in the measurement area is calculated.

As illustrated in [Figure 5](#) the radar spectrum is recorded for water flows up- and downstream. In the lower part of [Figure 5](#) the velocity spectrum of water flowing away from the radar sensor is displayed, in the upper part the spectrum of water flowing towards the sensor. The yellow area is the part of the spectrum used for analysis and the vertical green line indicates the resulting velocity.

By interpreting the radar spectra, velocity measurements can be analyzed in detail. A spectrum can have a narrow or broad peak, one or more maxima or it can identify only one velocity direction. Awareness of this can result in a modification of the settings for the velocity measurement.

For detailed information on how to proceed if more than one peak is visible in the radar spectrum please refer to [Appendix B](#).

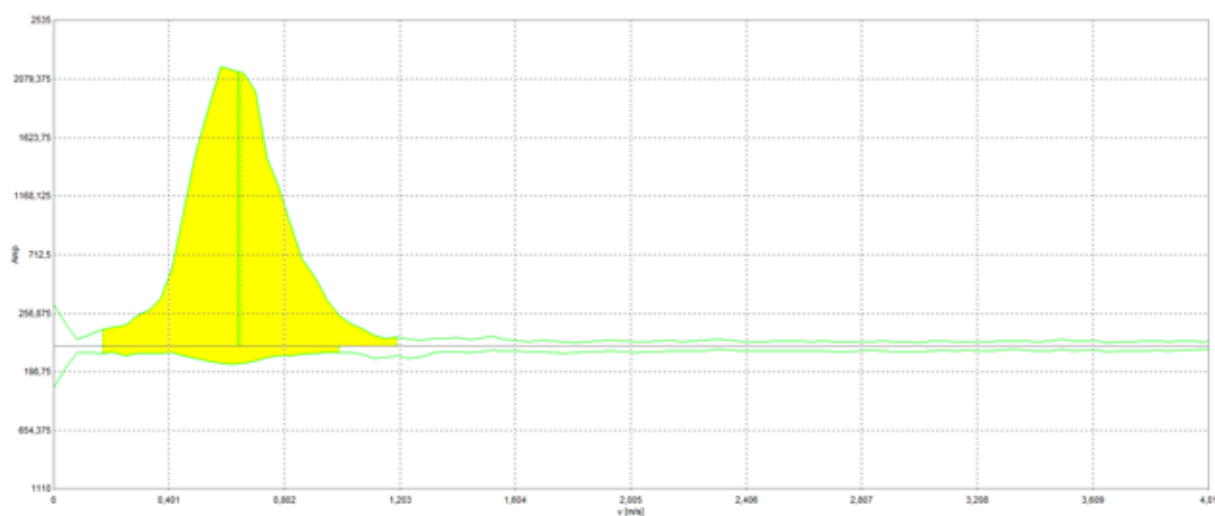

Figure 5 Radar spectrum

## 4.3 Determination of water discharge

### 4.3.1 Base equation

The discharge  $Q$  is the volume of water  $V$  flowing through a cross Section of a river per time unit  $t$ . Therefore the dimension is  $m^3/s$ ,  $l/s$ ,  $ft^3/s$  or  $m^3/day$ .

$$Q = \frac{V}{t}$$

By applying the continuity equation the expression above can be transformed into the base equation of the discharge measurement:

$$Q = A \times v_m$$

where  $A$  is the wetted cross-Sectional area and  $v_m$  the mean flow velocity.

The integrated velocity radar sensor measures the local velocity  $v_l$  at the water surface and not the mean velocity  $v_m$ . Therefore, a dimensionless correction factor  $k$  has to be implemented to calculate the mean velocity from the local velocity:

$$\frac{v_m}{v_l} = k \rightarrow v_m = k \times v_l$$

The  $k$ -factor depends on the flow conditions and consequently on the water level  $W$ . Its usual range is 60 to 90 % of  $v_l$ . In combination with the base equation the discharge is calculated:

$$Q = A(W) \times k(W) \times v_l$$

For the RQ-30+ a discharge table is generated from the cross-Sectional areas  $A(W)$  and the  $k$ -factors  $k(W)$  for different water levels. This table is stored in the RQ-30+ sensor and is the basis for the discharge calculation. It is essential that the water levels of the discharge table correspond to the same reference as the water level measurement of the RQ-30+ sensor.

### 4.3.2 k-Factors

The  $k$ -factors are determined by numerical hydraulic modelling. The  $k$ -factors mainly depend on the water level, the shape of the channel/river cross-Section, the turbulence of the flowing water and the mounting position of the RQ-30+ sensor. By applying a hydraulic model the total water level range can be determined and the discharge calculated from the time of installation. As the  $k$ -factors are site-specific they have to be determined for each measurement site.

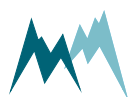

The PC software Q-Commander by Sommer Messtechnik can be used to compute k-factors based on hydraulic modelling. Additionally, reference measurements can be used to verify and correct modelled k-factors.

### 4.3.3 Cross-Sectional area

### 4.3.4 Discharge calculation

The water discharge is calculated from the measured values of  $W$  and  $v_l$  using the discharge table stored in the RQ-30+ sensor. The following scheme illustrates this procedure:

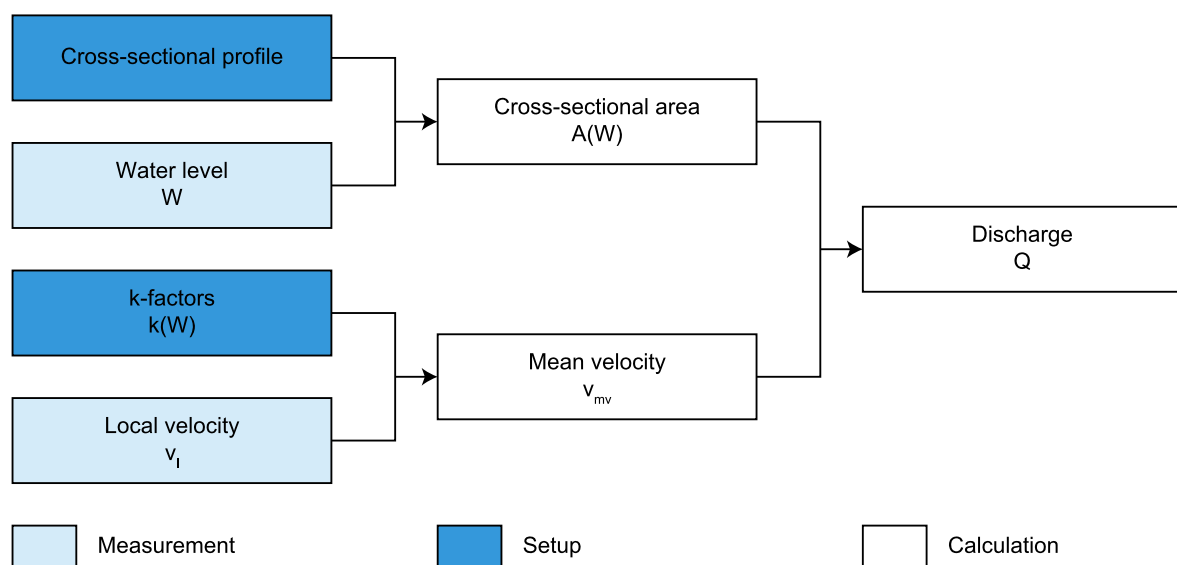

Figure 6 Discharge calculation scheme

## 5 Components

### 5.1 RQ-30+ device

#### 5.1.1 Velocity sensor

The velocity sensor of the RQ-30+ uses a frequency of 24.160 GHz at an output power of 26 dBm.

#### 5.1.2 Level sensor

The RQ-30+ contains a radar level sensor that operates at a frequency of 80 GHz.

#### 5.1.3 Main connector

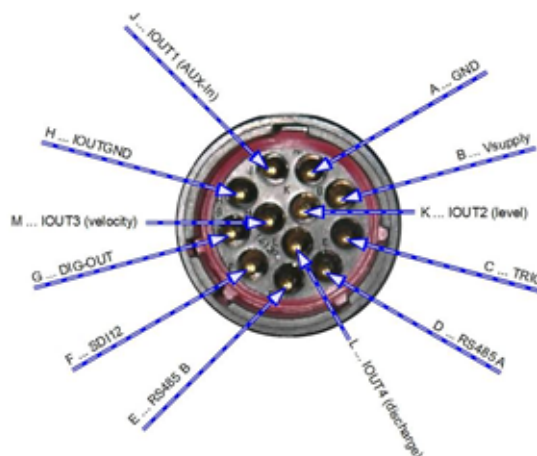

Figure 7 Pin configuration of connector MAIN

	Pin	Function	Description
Power supply	A	GND	Ground
	B	Vsupply	+6...+30 V
Trigger input	C	TRIG	low: 0...0.6 V high: 2...30 V
RS-485 interface	D	RS485 A	1 x RS-485 (1200...115200 Baud)
	E	RS485 B	
SDI-12 interface	F	SDI-12	1 x SDI-12 (1200 Baud)
Switched digital output	G	DIG-OUT	Max. 1.5 A
Analog outputs ( RQ-30+ a only)	H	IOUTGND	Analog ground
	J	IOUT1	Optional sensor (4...20 mA)
	K	IOUT2	Water level (4...20 mA)
	L	IOUT4	Discharge (4...20 mA)
	M	IOUT3	Velocity (4...20 mA)



**NOTE** The analog outputs and the trigger input are referenced to GND on pin H.

### 5.1.4 Connector LEVEL

The level-sensor is directly wired to the RQ-30+ velocity unit inside the metal housing.

	Pin	Function	Description
Ground	A	GND	Ground
Input 4...20 mA	B	LEVEL	4...20 mA
Supply	C	VOUT-LEVEL	12 VDC
-	D	-	-

Configuration of connector LEVEL

## 6 Specifications

Physical and environmental	
Power supply	9...30 VDC; Reverse voltage protection, overvoltage protection
Power consumption at 12 VDC	Standby approx. 1- Active measurement approx. 140 mA (default 30 sec)
Outputs	RS-485 ASCII or Modbus RTU SDI-12 Analog output 4...20 mA (14 bit, max. load 250 $\Omega$ ) Digital output (low: 0 V, high: Vsupply, max. 1.5 A)
Operating temperature	-40...85 °C (-40...185 °F)
Storage temperature	-40...85 °C (-40...185 °F)
Relative humidity	0...100 %
Protection rating	IP 67 (IP 68 on request)
Lightning protection	Integrated protection against indirect lightning with a discharge capacity of 0,6 kW Ppp
Housing material	Powder coated aluminum, vandalism-proof, plastic cover Stainless steel (on request)
Mounting bracket	$\varnothing$ 34...48 mm
Size L x W x H	295 x 160 x 210,5 mm (11.61 x 6.30 x 8,29 in)
Weight	5.4 kg (11.90 lb)

Velocity	
Detectable measurement range	0.08...16 m/s practical range (depending on surface water waves) 0.01...20 m/s technical range
Accuracy	$\pm$ 0.01 m/s (certified by METAS)
Resolution	1 mm/s
Direction recognition	+/-
Measurement duration	5...240 s

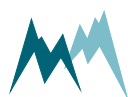

Velocity	
Measurement interval	8 s...5 h
Measurement frequency	24 GHz (K-Band)
Radar opening angle	12°
Distance to water surface	0.05...130 m (0.16...426.51 ft)
Noise reduction	Sommer Messtechnik ANR (advanced noise reduction) based on velocity spectrum analysis

Automatic vertical angle compensation	
Vertical inclination	Measured internally
Accuracy	± 1 °
Resolution	± 0.1 °

Water level measurement	15 m	30 m
Measurement range	0...15 m 49.2 ft.	0...30 m 98.4 ft.
Measurement frequency	80 GHz	
Resolution	1 mm	
Accuracy	± 2 mm	
Level sensor opening angle	8 °	4 °

Features	
Self check	Internal self check with code output for each measurement
AI Machine learning	Internal Machine learning for velocity and discharge, outputted with each measurement.
Hydraulic model	Dynamically and automatically calculated k-factors for discharge calculation
Data quality	Internal measurement quality value output with each measurement

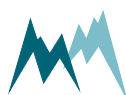

# 7 Installation

## 7.1 Site selection

The selection of a suitable measurement site for the RQ-30+ is crucial for the reliability and accuracy of the measurement results. Several aspects related to the hydraulic situation and the mounting of the sensor have to be considered.

### 7.1.1 Hydraulic requirements

#### 7.1.1.1 Cross-Sectional velocity distribution

In general, the cross-Sectional velocity distribution at the measurement site must not be changed. For example, fluctuating inflows and regulated weirs can influence the measurements. Therefore a minimum distance to such influences of 5...10x the channel width up- and downstream of the measurement site is recommended. The following drawings illustrate some examples:

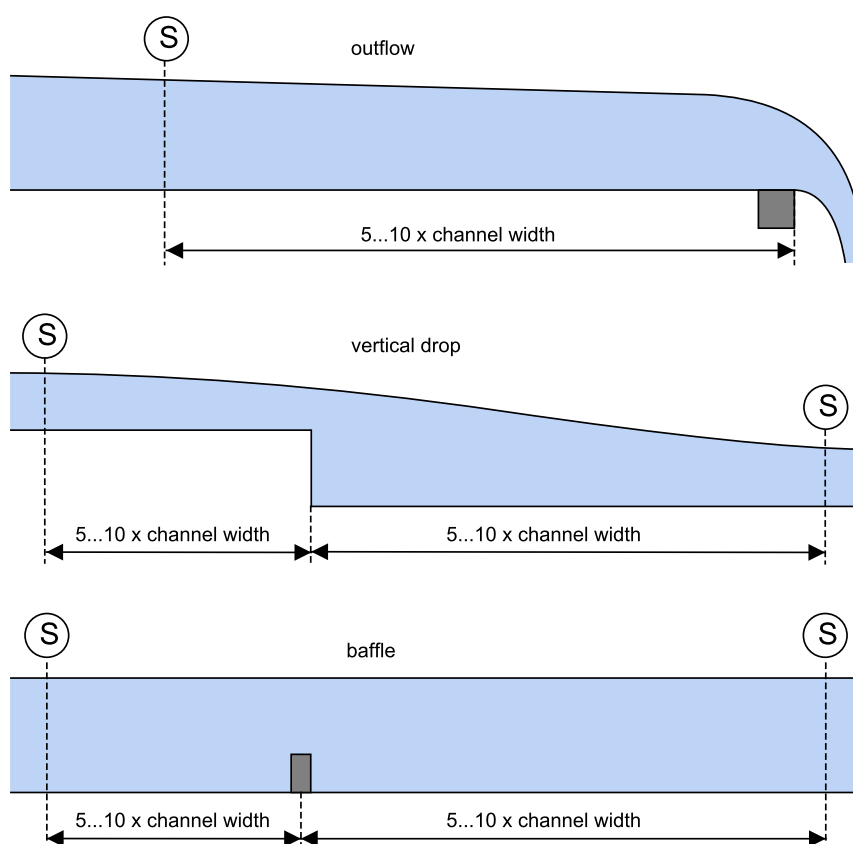

Figure 8 Positioning of RQ-30+ sensor under different flow conditions

### 7.1.1.2 Stationary waves

There must be no stationary waves present in the field of view of the RQ-30+ as they can negatively influence the measurement accuracy. Stationary waves may be caused by big stones and other obstacles; their impact depending on water level. Stationary waves cause errors in angle as the radar impulse is partly reflected from them and not the plane water surface. Also, they may overestimate the water level.

### 7.1.1.3 Range with unchanging cross Section

The cross-Section of the channel/river in the vicinity of the flow measurement needs to be stable. Pillars of bridges and bends or corners in the flow channel represent changes of the cross-Section. The minimum distance with a constant cross-Section upstream and downstream of the sensor should be 5...10x the channel width.

### 7.1.1.4 Stable cross-Section

The calculation of the discharge requires the cross-Sectional area of the channel/river (see [Determination of water discharge](#)). Therefore, the cross Section of the river must not change as this causes the need of a new site calibration. Examples of a changing cross-Section are erosion of the channel bed, deposition of debris or the relocation of sediments. Changes of the cross-Section may be identified by changes in the W-v relation.

### 7.1.1.5 Adequate wave movements

Waves or ripples with a height of at least 2 mm have to be present at the water surface over the full expected water level range. Especially very slow flowing rivers often do not meet this requirement (see also [Conditions of the water surface](#)).

### 7.1.1.6 Influence of wind

For slow moving, deep rivers the flow velocity measurement may be interfered by waves which are caused by wind. If such an influence is observed, the measurement site should be shielded from wind by proper means or an alternative site should be considered.

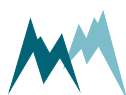

## 7.1.2 Installation requirements

### 7.1.2.1 Viewing direction

It is recommended to install the RQ-30+ with its tip pointing upstream. This has some essential advantages: For installations on bridges the influence of pillars on the water flow conditions are avoided. Additionally, the influence of precipitation is eliminated by a direction separation obtained from the velocity spectrum (see [Flow direction separation](#)).

### 7.1.2.2 Free field of view

The RQ-30+ sensor interprets all movements in its field of view. Therefore, no moving objects shall be present in the field of view of the RQ-30+. [Figure 9](#) shows the size of the measurement spot and its distance from the RQ-30+ sensor for different installation heights. Consider these dimensions when installing the sensor.

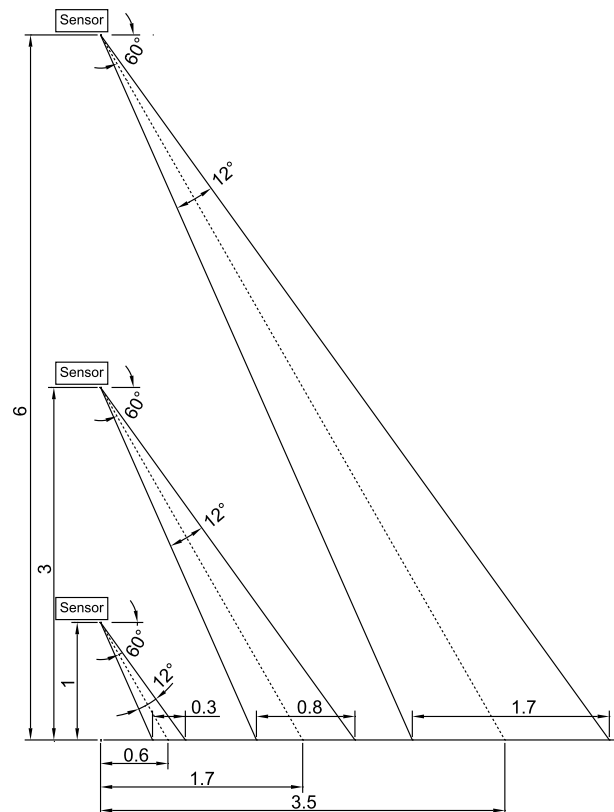

**Figure 9** Measurement spot size for different mounting heights (dimensions in m)

### 7.1.2.3 Installation underneath bridges

When the RQ-30+ is installed underneath a bridge it has to be assured that no rain or melt water is dripping through the field of view of the velocity radar. The occurrence of such events may influence the measurement considerably.

### 7.1.2.4 Installation on extension arms

The RQ-30+ sensor can be mounted on an extension arm protruding from a river bank or channel wall. Sommer Messtechnik suggests installing a rotatable extension arm to facilitate maintenance.

### 7.1.2.5 Installation above open channels or rivers

The RQ-30+ can be mounted in a range between 0.5 to 15 m above the water surface. With the extended measurement range the RQ-30+ can be installed at a height up to 35 m above the water surface.

The sensor has to be mounted on a rigid structure that does not move, e.g. support beams or handrails of a bridge. An exception is the mounting on cable ways, which requires determination of the sensor inclination before each measurement to account for swinging (see parameter definition [Inclination measurement](#)).

## 7.1.3 Documentation

It is recommended to document the measurement site with pictures for future analysis. These may include:

- Measurement site with the installed sensor
- River or channel facing upstream and downstream
- Flow conditions at the measurement site
- Roughness of the river bed or channel walls

## 7.2 Performing a site survey

Every measurement site requires an individual survey to determine the local hydraulic boundary conditions. These conditions are aggregated the a discharge table, which is used to calculate the discharge based on the measured water level and flow velocity.

Follow the instructions below to perform a complete site survey:

### 1. Select the reference coordinate system

The measurements of the water level, the mounting position of the RQ-30+ sensor and points in the cross-sectional profile have to relate to each other. Especially the water levels defined in the discharge table and the water levels measured with the RQ-30+ sensor have to be consistent. See [Map the cross-sectional profile](#) for the available options.

When selecting the reference system for the measurement site, existing installations for water level measurements should be considered.

#### Sites with an existing water level measurement

If a water level measurement is already present at the measurement site, i.e. gauge plate or gauge sensor, it is recommended to use the gauge zero (GZ) of the existing measurement as the reference level. This level is usually unique and defined permanently. Moreover, consistency in the existing water level measurement and the RQ-30+ measurement simplifies interpretation. As illustrated in [Figure 10](#) the level of the gauge zero has to be known in the reference system.

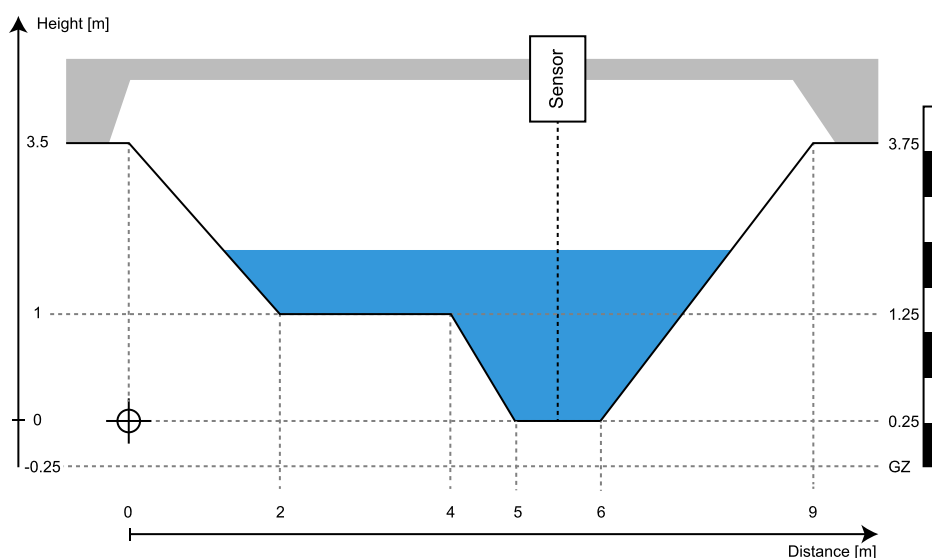

**Figure 10** Gauge zero (GZ) of a gauge plate in reference to a channel profile

In the example shown in [Figure 10](#) gauge zero is at -0.25 m in the reference coordinate system of the cross-Section H.

#### Sites without an existing water level measurement

For measurement sites without an existing water level measurement a new reference has to be defined. It is recommended to select a stable, fixed point as reference for future verification. It is essential to exactly document this point and its relation to the water level W.

For channels with a stable lining a point on the surface can be selected as a reference and gauge zero simultaneously. Thus, the water level can be determined easily and the adjustment procedure for the water level measurement of the RQ-30+ sensor is simple.

For all other situations a fixed point has to be selected. Examples are survey points or stable, accessible points on bridges or other structures. This reference point has to be mapped in the coordinates of the cross-Sectional profile. The point does not need to be defined as gauge zero, but needs to relate to it.

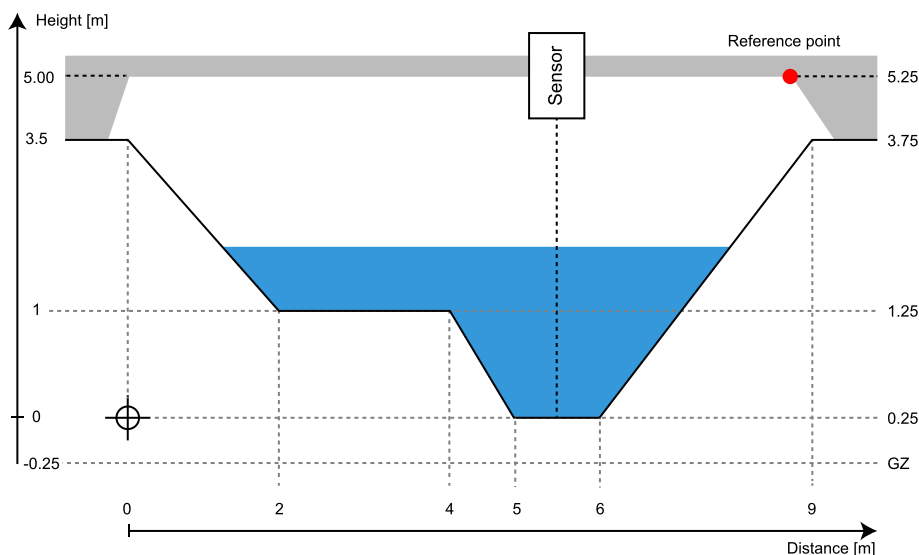

Figure 11 Gauge zero (GZ) with a fixed point referenced to it

In the example of Figure 11 a fixed point was defined on a bridge. The height of the point is 5 m in the reference coordinate system of the cross-Section H. The gauge zero was defined as -0.25 m. Thus, the fixed point is at 5.25 m in the coordinate system of the water level measurement W.

## 2. Map the cross-sectional profile

The cross-Sectional profile represents a vertical cut through the channel from the river bed to the maximum expected water level. It is required for the calculation of the wetted cross-Sectional areas  $A(W)$  and the modeling of the k-factors  $k(W)$  (see [Determination of water discharge](#)).

The cross-Section is usually taken at the position of the water level measurement. A point in the profile is specified in one of the following coordinates:

- height relative to bottom with positive values upwards, see [Figure 12](#)
- absolute height above sea level, see [Figure 13](#)
- height relative to top with positive values downwards, see [Figure 14](#)

## 3. Determine the roughness of the riverbed

An estimation of the roughness on the edges of the cross-Sectional profile is necessary to model the k-factors. The roughness is specified as absolute roughness  $k_s$ , Strickler coefficient  $k_{St}$  or Manning co-efficient  $n$ . In the Q-Commander software the roughness is specified in categories, e.g. "Sand bed" or "Brickstone walls".

4. Locate the position of the RQ-30+

The exact position of the RQ-30+ in the reference system has to be known (see Figure 15). This information is essential for modelling the k-factors and adjusting the water level measurement.

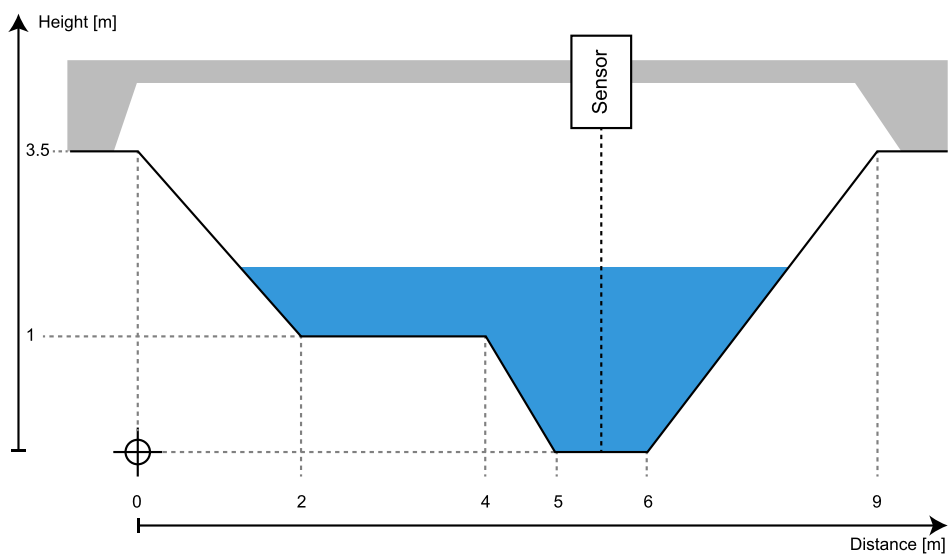

Figure 12 Cross-Sectional profile with height relative to bottom

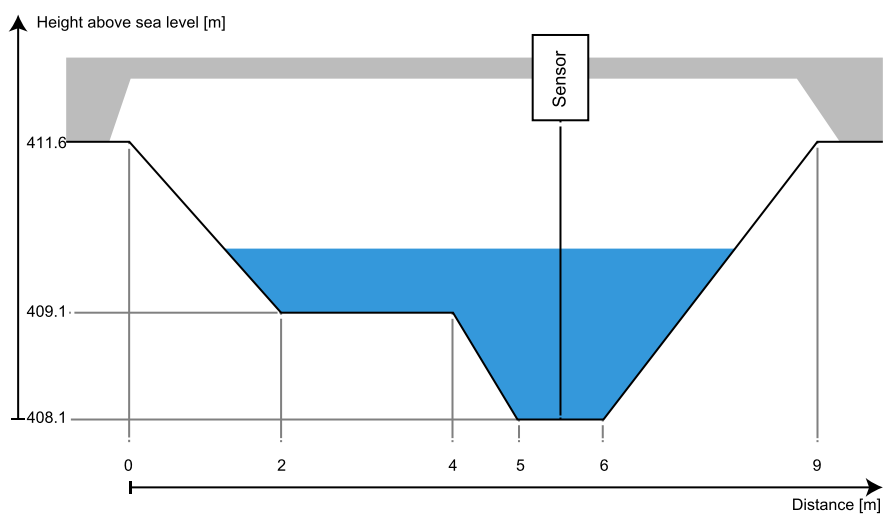
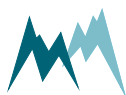

Figure 13 Cross-Sectional profile with absolute heights



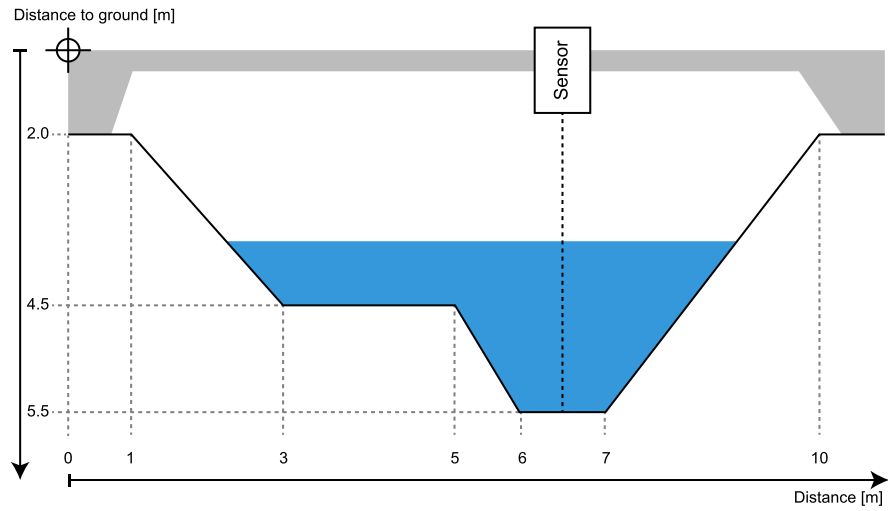

Figure 14 Cross-Sectional profile with heights relative to top

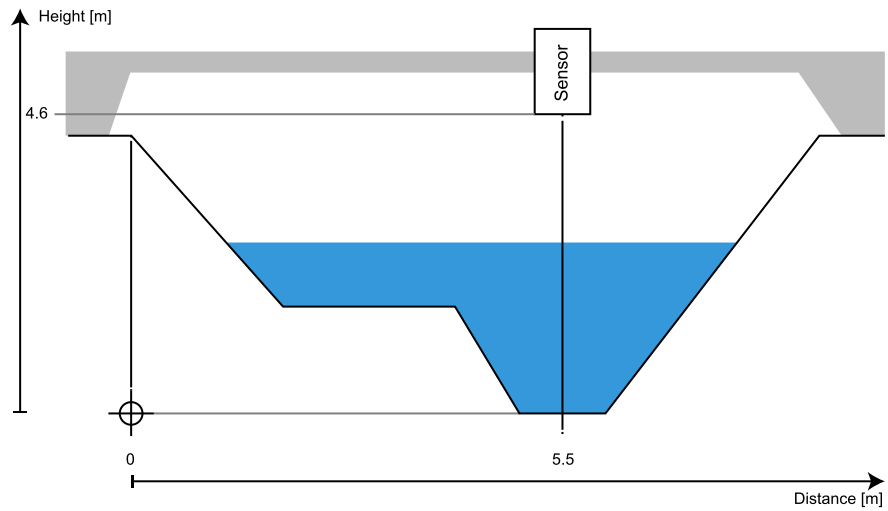

Figure 15 Cross-Sectional profile with RQ-30+ position relative to bottom

5. Build the discharge table

The survey of the measurement site is expressed in the form of a discharge table as shown in [Table 1](#). This table is stored in the RQ-30+ sensor and is the basis for the calculation of the discharge as described in [Discharge calculation](#).

The discharge table contains the cross-Sectional areas  $A(W)$  and  $k$ -factors  $k(W)$  of different water levels  $W$ . The areas  $A(W)$  are derived from the cross-Sectional profile,  $k$ -factors  $k(W)$  are determined according to [k-Factors](#).

The discharge table can contain up to 16 entries which are ordered from low to high water levels.  $A(W)$  and  $k(W)$  values are interpolated linearly to measured water levels.

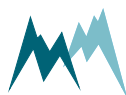

The discharge table can be created with the software Q-Commander by Sommer Messtechnik. After entering the cross- Sectional profile, the channel/river roughness and the sensor position the discharge table is calculated automatically. This table can then be transferred to the RQ-30+ sensor.

	Status	Level (W)	K value	Area (A)
		[m]	[ ]	[m^2]
01	on	0.4	64.0	4.7
02	on	0.6	68.7	9.5
03	on	0.8	72.1	14.4
04 ... 14	...	...	...	...
15	on	4.9	79.5	141.8
16	on	6.7	80.7	202.4

Table 1 Example of a discharge table

## 7.3 Things to consider for installation

### 7.3.1 Power supply

The RQ-30+ is designed for extreme environmental conditions at remote sites and with no grid connection. The sensor switches automatically into standby-mode between measurements and thus consumes only approx. 3.5 Ah per day which can be supplied by a 12V-solar-generator mounted to the mast.

### 7.3.2 Signal cables

#### 7.3.2.1 Maximum cable length

Please consider the maximum cable lengths for the applied transmission protocol:

Protocol	Max. cable length
SDI-12	~60 m (depending on wire cross section and number of sensors)
RS-485	~300 m

Table 2 Maximum cable lengths



**NOTE** Cable lengths longer than 60 m require a heavier gauge wire if the power supply drops below 11 V.

### 7.3.3 Lightning protection

If the underground at the measurement site permits sufficient current dissipation it is strongly recommended to equip the sensor support or mast with properly dimensioned lightning protection. Consult an expert for advice.

The RQ-30+ is protected against overvoltage. If a data logger is mounted to the mast, its ground lug must be properly connected to earth ground.

## 7.4 Required tools and equipment

Prepare the following tools and equipment to install the RQ-30+:

Qty	Tool
1	Mounting tube $\varnothing 34...48$ mm
1	Cable ties
1	Wire cutter

## 7.5 Mounting



### ATTENTION

The RQ-30+ must be installed parallel to the water surface! The angle between the water surface and the device must not exceed  $\pm 2.5^\circ$ .

As illustrated in [Figure 16](#) the RQ-30+ must be installed parallel to the water surface in both directions: along and perpendicular to the water flow. Additionally, the sloping angle has to be entered

in the parameter **River inclination**. The sloping angle is always entered as a positive value, irrespective of the viewing direction of the sensor.

In tidal situations where both flow directions occur, the RQ-30+ should always be mounted horizontally and **River inclination** should be set to 0.

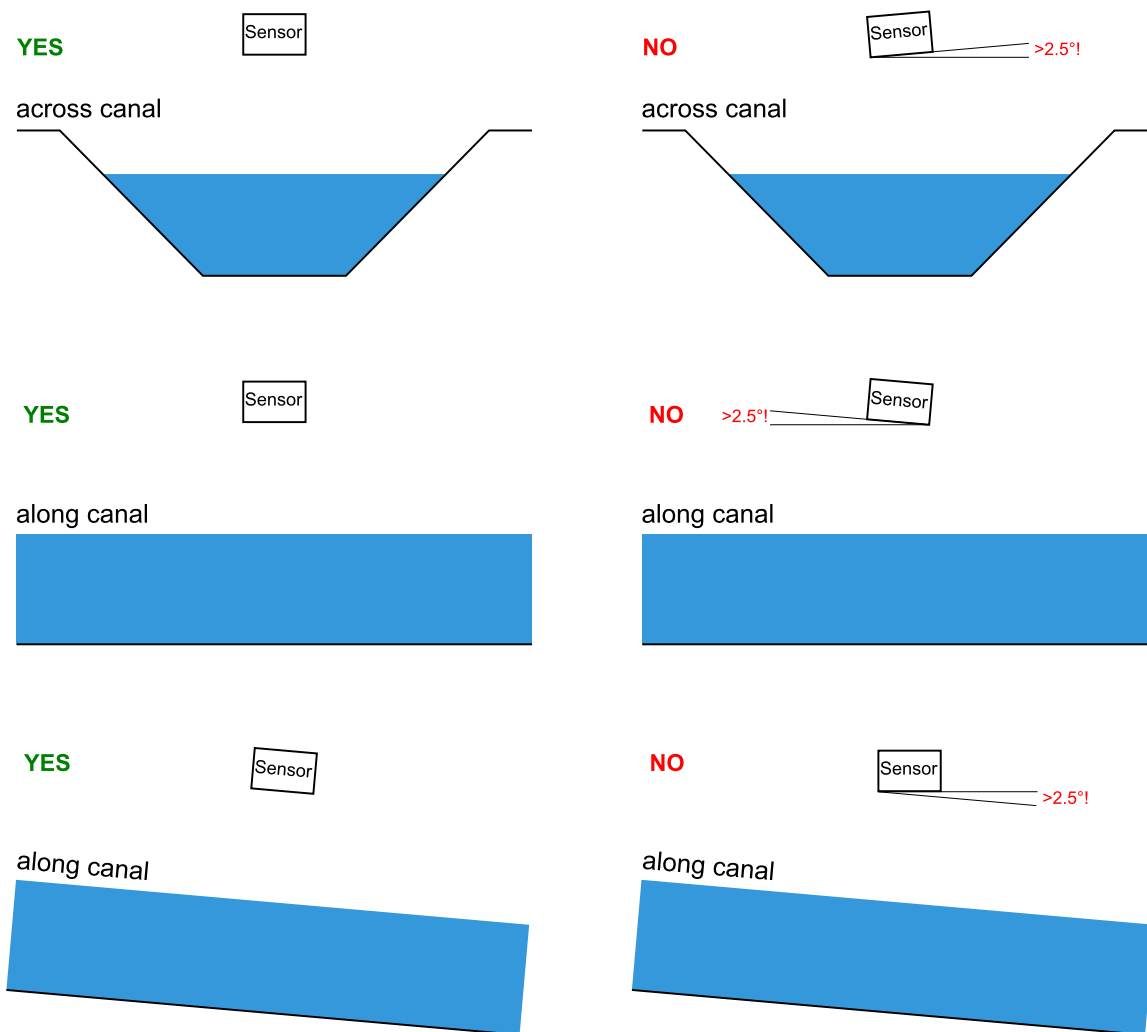
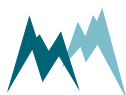

Figure 16 Parallel sensor installation

## 7.6 Wiring

### 7.6.1 RS-485 wiring

Connect the RQ-30+ to a data logger or RS-485 network according to the figure below.



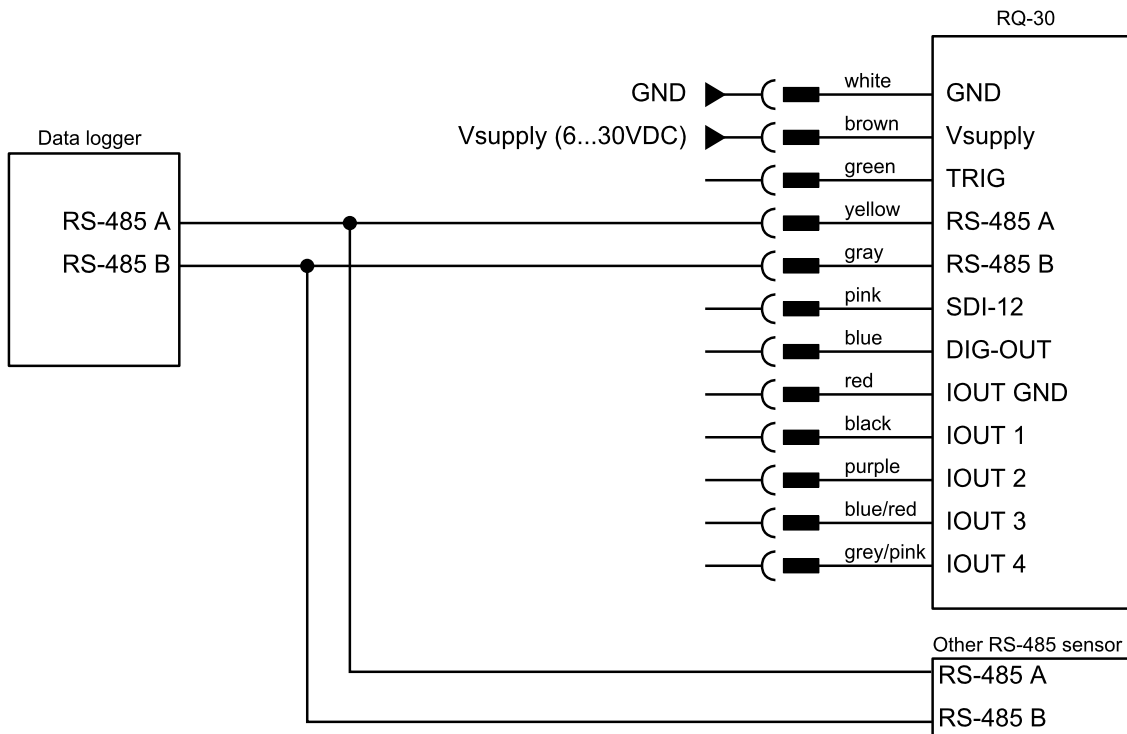

**ATTENTION**  
 If multiple Sommer Messtechnik devices are connected to a data logger over the same bus, all devices must share the same ground (GND)!

### 7.6.2 SDI-12 wiring

Connect the RQ-30+ to a data logger by SDI-12 according to the figure below. SDI-12 uses a shared bus with a ground wire, a data wire (indicated as SDI-12) and an optional +12 V wire.

**NOTE** The connection with the 12 V power supply is optional and depends on the connected SDI-12 master device (typically a data logger).

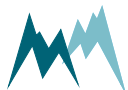

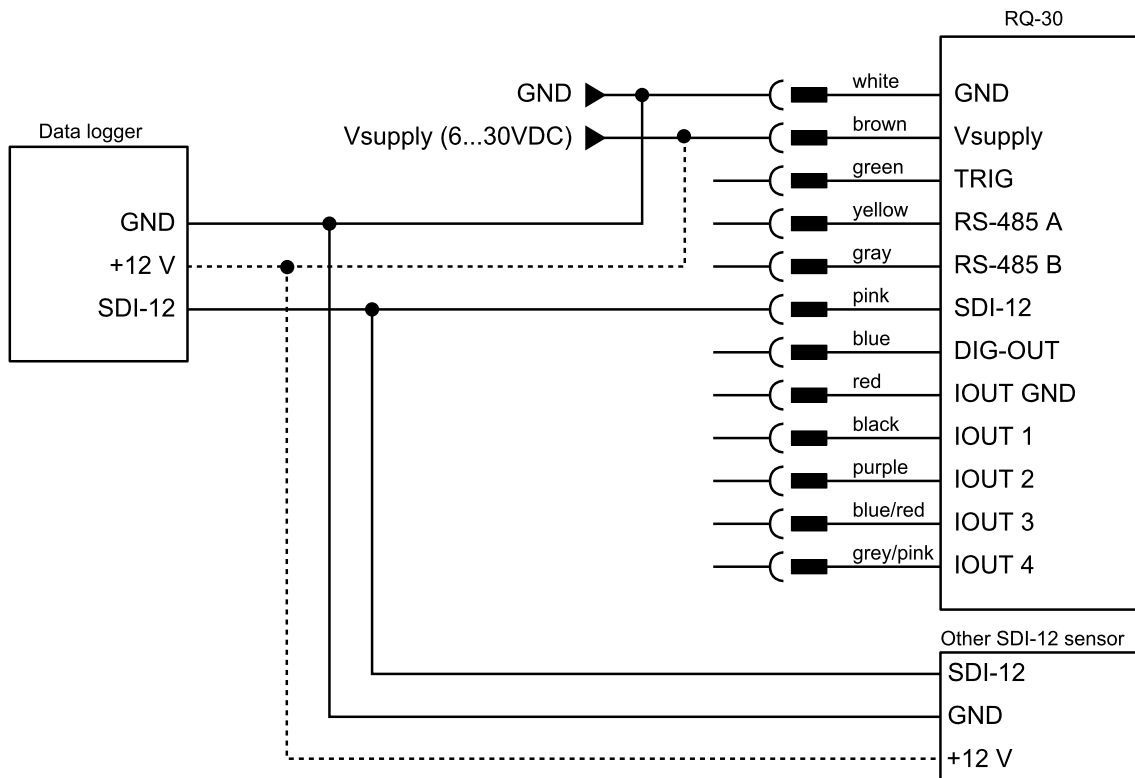
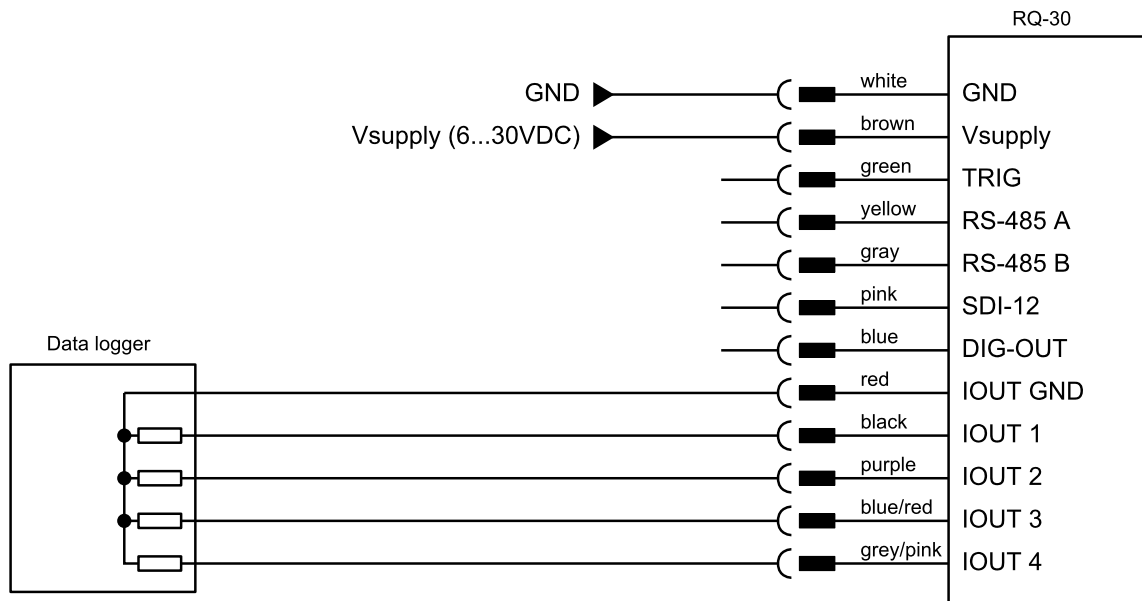

Figure 17 Wiring of the RQ-30+ with a data logger via SDI-12

### 7.6.3 How to wire analog outputs

Connect the analog outputs of the RQ-30+ to a data acquisition device according to the figure below.



**NOTE** If a data logger is connected to the IOUT outputs, the resistance of the logger input(s) must not exceed 470  $\Omega$ .

## 7.7 Adjustment of water level

Once the RQ-30+ has been installed at its final location, and has been configured completely, the water level measurement has to be adjusted to the present water level.

Follow the steps below to perform the water level adjustment:

1. Test the water level measurement by clicking [Test](#) in the parameter menu [Level \(W\)](#) of the Q-Commander.
2. If the displayed water level does not match the manually measured level click [Adjustment](#) in the parameter menu [Level \(W\)](#).
3. Verify the measured water level by applying the [Test](#) function again.

## 7.8 Start-up

After successful testing, verify that the measurement data are recorded by your data acquisition system and check the data transmission to the remote server if applicable.

## 8 Operation

### 8.1 Connect device to PC

1. Install the Q-Commander support software (see [Installation of Q-Commander](#) )
2. Connect the yellow and gray wires of the sensor cable to the RS-485 to USB converter cable and plug it into your PC as illustrated in the figure below.
3. Connect a 9...30 VDC power supply to the RQ-30+.
4. Click on **Communication assistant** on the right-hand side of the Q-Commander window and follow the instructions. During this procedure the communication assistant will search for connected devices. Upon successful completion, the new connection is added to the connections list (tab **Connections (F8)**).
5. In the **Communication** Section at the right-hand side of the Q-Commander window select Mode **Connection** and the previously created connection from the drop-down list.
6. Click **Connect** to establish a connection with the RQ-30+. If the connection was successful a green icon is displayed at the top-right corner of the Q-Commander window.
7. Select the tab **Parameters (F2)** and click **Download parameters from device** on the left side of the Q-Commander window. The complete parameter list is transferred from the sensor to your PC and displayed in the **Parameter** window.

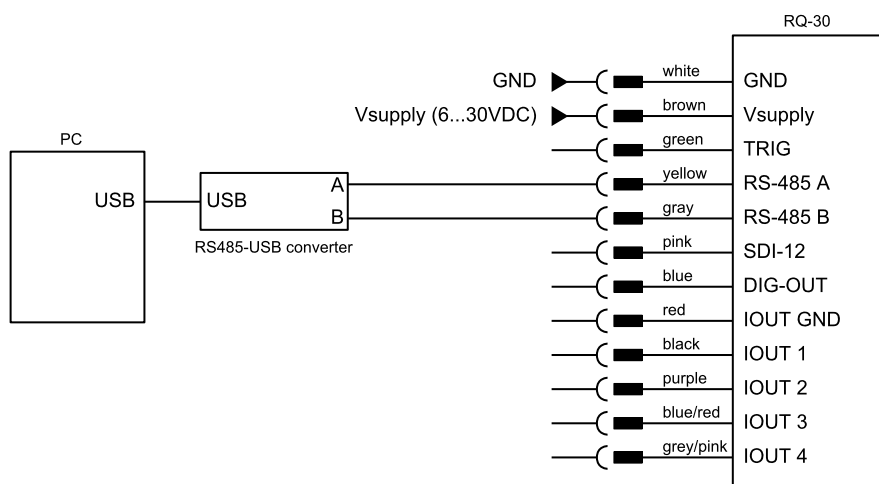

To activate the communication between your device and the Q-Commander software follow the steps described in [Working with connections](#).

# 9 Maintenance

The RQ-30+ generally does not require any special maintenance. However, the device should be inspected occasionally for damage and a dirty sensor surface. To remove dirt use a wet cloth with little force. Do not use any abrasive detergent or scraping tool!

## 9.1 Device status

During operation the RQ-30+ continuously performs a self-check to identify any abnormal system behavior or device failure. This self-check is returned by the RQ-30+ as a code (SFCH-code) with a value of 1 to 16. In the table below the SFCH-code together with their cause and solution. An icon as specified in the legend below is linked to each SFCH-code to indicate the significance of a detected abnormality.

To view the self-check message open the Q-Commander, connect to the RQ-30+ and open the tab **Measurements (F3)**. In the main window a section named **Self-check** opens and displays the current device status.



**NOTE** The parameter **Status** must be set to *off = SFCH (self-check, default)* in order to activate the self-check feature.

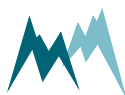

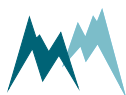

Symbol	SFCH-Code	Description	Cause	Solution
	16	Sensor returns 999997, i.e., level can not be measured or measurement value has not been returned.	<ul style="list-style-type: none"><li>■ Sensor connected incorrectly.</li><li>■ Sensor has just been powered.</li><li>■ Sensor is malfunctioning.</li></ul>	<ol style="list-style-type: none"><li>1. Check correct sensor installation (facing water surface).</li><li>2. Check wire connections.</li><li>3. Wait until the sensor has acquired its first measurements.</li><li>4. Re-power the sensor and start <b>Spectrum mode</b> to trigger measurements.</li></ol>

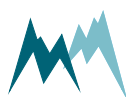

Symbol	SFCH-Code	Description	Cause	Solution
 	15	Sensor Inclination angle is outside the range $\pm 2.5^\circ$ (only applicable if <b>Inclination measurement</b> is set to <i>every measurement</i> ).	<ul style="list-style-type: none"> <li>■ Sensor mounted improperly.</li> <li>■ <b>River inclination</b> set inadequately.</li> <li>■ Calibration of inclination sensor incorrect.</li> </ul>	<ol style="list-style-type: none"> <li>1. Verify that the sensor is installed parallel to the water surface (level measurement is perpendicular to water surface). This also applies to sloping rivers.</li> <li>2. If sensor is installed with an inclination, verify that <b>River inclination</b> and <b>Viewing direction</b> are correct.</li> <li>3. Check if the velocity sensor sits firmly in its housing and that the housing is not crooked.</li> <li>4. Make sure the sensor is not swinging, wobbling or heavily vibrating. Reinforce any brackets if required.</li> <li>5. In the setting <b>Information</b> of sub-menu <b>RS-485 (COM)</b>, select <b>&amp; Analysis</b> values. This will add the inclination angle to the data output. Check if the displayed angle is plausible and that it changes accordingly if you</li> </ol>



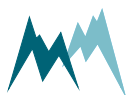

Symbol	SFCH-Code	Description	Cause	Solution
				tilt the sensor. 6. Contact Sommer Messtechnik to recalibrate or replace the inclination sensor.
 	14	Velocity too high for correct determination.	<ul style="list-style-type: none"> <li>■ Sensor may be mounted improperly or velocity settings are configured incorrectly.</li> </ul>	<ol style="list-style-type: none"> <li>1. Check/adjust sensor position</li> <li>2. Check/adapt settings in menus <a href="#">Velocity</a> and <a href="#">Tech. velocity (v)</a>.</li> </ol>



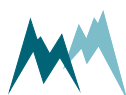



Symbol	SFCH-Code	Description	Cause	Solution
	13	Velocity too low for correct determination.	<ul style="list-style-type: none"> <li>Water flows very slowly and/or river has high waves. This may lead to overlapping velocity peaks.</li> </ul>	<ol style="list-style-type: none"> <li>Rivers with high waves should flow reasonably fast; change measurement site if this is not the case.</li> <li>If waves are small, reduce <b>Minimum velocity</b> and reduce the range between <b>Minimum velocity</b> and <b>Maximum velocity</b>.</li> <li>Check opposite direction content and increase <b>Stop, max. opp. direction</b>.</li> <li>Change the distance to the water surface.</li> <li>Mount the sensor in the reverse direction.</li> <li>Create artificial surface waves.</li> <li>If error persists, change measurement spot to one with higher flow velocities.</li> </ol>
	11	Not specified	-	-

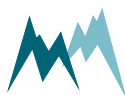





Symbol	SFCH-Code	Description	Cause	Solution
	10	Velocity indicates wrong flow direction.	<ul style="list-style-type: none"> <li>■ Sensor may not be properly configured.</li> <li>■ Insufficient waves on the water surface.</li> <li>■ Strong winds.</li> </ul>	<ol style="list-style-type: none"> <li>1. Check parameter <a href="#">Viewing direction</a>.</li> <li>2. Mount the sensor in the reverse direction</li> </ol>
 	9	Velocity cannot be determined.	<ul style="list-style-type: none"> <li>■ Flow conditions may be outside the range of detection.</li> <li>■ Sensor may be configured incorrectly or is malfunctioning.</li> </ul>	<ol style="list-style-type: none"> <li>1. Record some spectra and evaluate their quality. See also <a href="#">Examples of velocity spectra</a>.</li> <li>2. Check/adapt settings in menu <a href="#">Velocity</a>.</li> <li>3. Check opposite direction content and increase <a href="#">Stop, max. opp. direction</a>.</li> <li>4. Change the distance to the water surface.</li> <li>5. Mount the sensor in the reverse direction</li> <li>6. Create artificial surface waves.</li> <li>7. If error persists, change measurement site.</li> </ol>

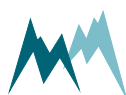





Symbol	SFCH-Code	Description	Cause	Solution
 	8	Opposite direction content is too high.	<ul style="list-style-type: none"> <li>■ Sensor may not be properly configured or is malfunctioning.</li> </ul>	<ol style="list-style-type: none"> <li>1. Check/adapt settings in menus <a href="#">Velocity</a>.</li> <li>2. Check opposite direction content and increase <a href="#">Stop, max. opp. direction</a>.</li> <li>3. Change the distance to the water surface.</li> <li>4. Mount the sensor in the reverse direction</li> <li>5. Create artificial surface waves.</li> <li>6. If error persists, change measurement site.</li> </ol>
 	7	Quality (SNR) is too low	<ul style="list-style-type: none"> <li>■ Sensor may not be properly configured or is malfunctioning.</li> <li>■ Insufficient waves on the water surface.</li> </ul>	<ol style="list-style-type: none"> <li>1. Check/adapt settings in menus <a href="#">Velocity</a>.</li> <li>2. Check opposite direction content and increase <a href="#">Stop, max. opp. direction</a>.</li> <li>3. Change the distance to the water surface.</li> <li>4. Mount the sensor in the reverse direction</li> <li>5. Create artificial surface waves.</li> <li>6. If error persists, change measurement site.</li> </ol>

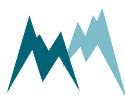



Symbol	SFCH-Code	Description	Cause	Solution
 	6	No cross-sectional area determined	<ul style="list-style-type: none"> <li>■ Sensor cannot determine the cross-sectional area</li> </ul>	<ol style="list-style-type: none"> <li>1. Check/adapt settings in menu <a href="#">Level (W)</a> and perform a level adjustment.</li> <li>2. Verify that the profile is correct and check if the water level is within the range of the profile.</li> <li>3. Verify that the sensor returns velocity values.</li> </ol>
 	5	Sensor did not measure flow velocity.	<ul style="list-style-type: none"> <li>■ Insufficient waves on the water surface.</li> </ul>	<ol style="list-style-type: none"> <li>1. Check/adapt settings in menu <a href="#">Velocity</a></li> <li>2. Check Quality (SNR) and opposite direction content and increase <a href="#">Stop, max. opp. direction</a>.</li> <li>3. Change the distance to the water surface.</li> <li>4. Mount the sensor in the reverse direction</li> <li>5. Create artificial surface waves.</li> <li>6. If error persists, change measurement site.</li> </ol>







Symbol	SFCH-Code	Description	Cause	Solution
 	4	Water level is above WMA, maximum level	<ul style="list-style-type: none"> <li>■ May occur if W-v learning has been optimized for low water levels (high water levels are extrapolated).</li> <li>■ Water level adjustment has not been performed.</li> <li>■ Sensor has been improperly positioned.</li> <li>■ An obstacle may protrude into the field of view of the sensor.</li> </ul>	<ol style="list-style-type: none"> <li>1. OK if acceptable.</li> <li>2. Check/adapt settings in menu <a href="#">Level (W)</a> and perform a level adjustment.</li> <li>3. Verify that the profile is correct and match it to the water level settings.</li> <li>4. Check that the field of view is free of any obstacles.</li> </ol>
 	3	Water level is below WCF, cease to flow level.	<ul style="list-style-type: none"> <li>■ May occur during low water levels.</li> <li>■ Water level adjustment has not been performed.</li> <li>■ Sensor has been improperly positioned.</li> <li>■ An obstacle may protrude into the field of view of the sensor.</li> </ul>	<ol style="list-style-type: none"> <li>1. OK if WCF value &gt;0 is required.</li> <li>2. Set WCF to 0.</li> <li>3. Check/adapt settings in menu <a href="#">Level (W)</a> and perform a level adjustment.</li> <li>4. Verify that the profile is correct and match it to the water level settings.</li> <li>5. Check that the field of view is free of any obstacles.</li> </ol>



Symbol	SFCH-Code	Description	Cause	Solution
	2	Values of WCF, cease to flow level, WLL, low level border and WMA, maximum level are equal.	<ul style="list-style-type: none"> <li>Wrong operator input.</li> </ul>	<ol style="list-style-type: none"> <li>OK if acceptable.</li> <li>Check/adapt settings in menu Level (W)</li> <li>Set the values of WCF, cease to flow level, WLL, low level border and WMA, maximum level correctly. WMA &gt; WLL &gt; WCF</li> </ol>
	1	No discharge table available.	<ul style="list-style-type: none"> <li>Discharge table has not been uploaded.</li> <li>Discharge table has only one entry.</li> </ul>	<ol style="list-style-type: none"> <li>Upload discharge table.</li> <li>Check entries of discharge table.</li> </ol>
	0	Sensor operates normally	-	-

Device status codes

Symbol	Status
	Device failure
	Function check
	Out of range
	Normal operation with optimized setup
	Normal operation

Device status symbols

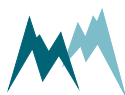

# 10 Support software Q-Commander

## 10.1 Software features

The Q-Commander is a multipurpose software tool to configure and operate any Sommer Messtechnik device. It offers the following functions:

- Communication with Sommer Messtechnik sensors and data loggers via serial connection, modem, socket, IP-call and Bluetooth®
- Management of connections and stations
- Configurations of sensors and data loggers
- Live data monitoring and storage
- Data management including download from data loggers and transmission to MDS (Measurement Data server)
- Terminal window to check data transfer and to access device settings directly

## 10.2 System requirements

The Q-Commander software supports 32- and 64-bit versions of Windows 7 SP1, Windows 8, Windows 8.1, Windows 10 and Windows 11.

For correct operation Microsoft® .NET Framework 4.5 or later must be installed.

## 10.3 Installation of Q-Commander

Follow the steps below to install the Q-Commander software:

1. Plug the USB stick shipped with the device into your PC.
2. Double-click the [commander.msi](#) installer file on the USB drive.

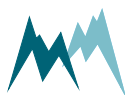

3. Click **Next** on the pop-up window



4. Read the instructions and click **Next**

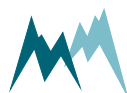
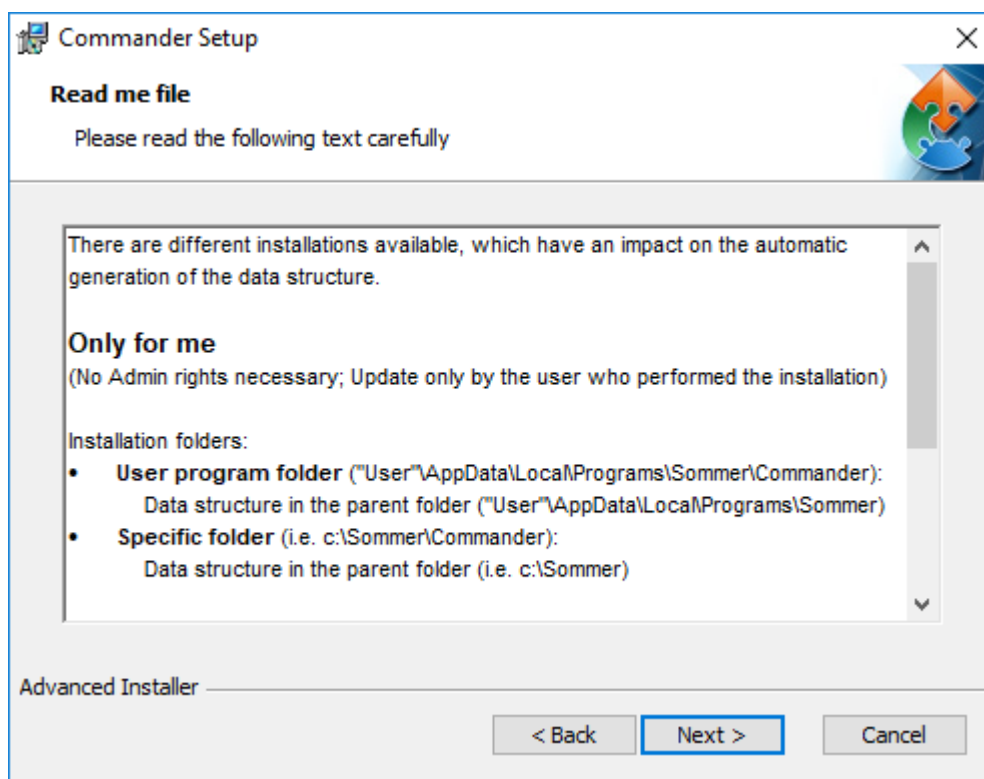

5. Select the installation type and click **Next**

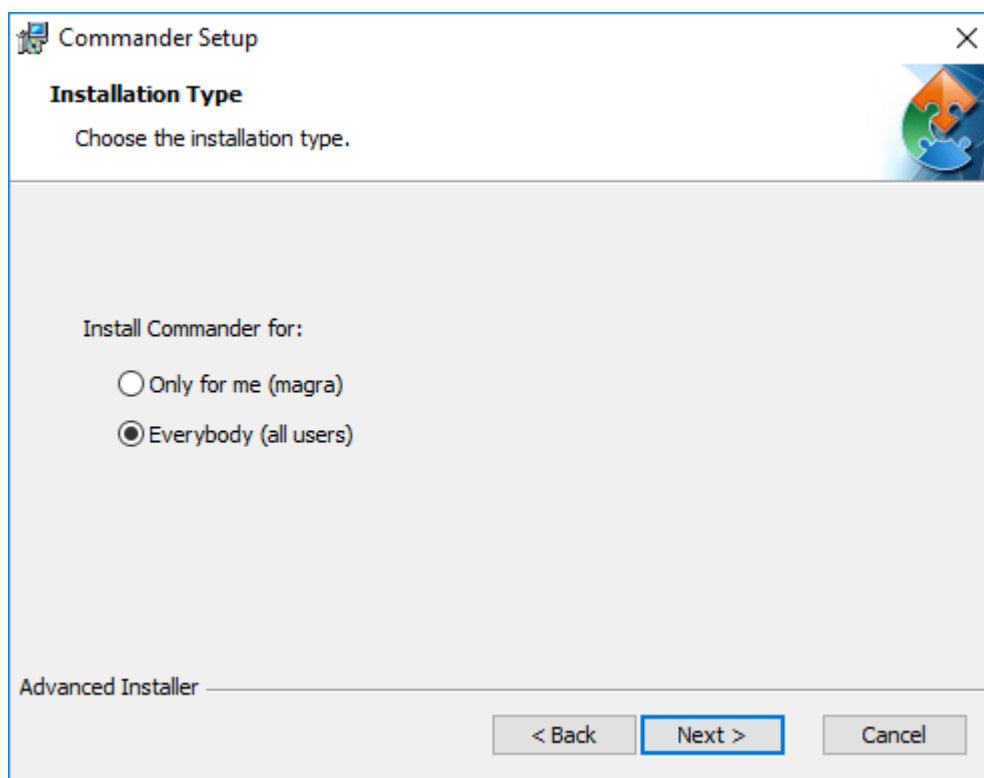

#### NOTE

Two installation types are available. Depending on the selection, the access rights and the folder structure differ:

##### **Only for me**

No admin rights are required. Updates are only available to the user who installed the software.

Installation folders:

- User program folder:  
Users\User\AppData\Local\Programs\Sommer\Commander  
Data structure:  
Users\User\AppData\Local\Programs\Sommer
- Specific folder (default):  
C:\Sommer\Commander  
Data structure (default):  
C:\Sommer

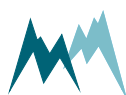



### Everybody

Admin rights are required. Updates may only be performed by system administrators.

Installation folders:

- Standard program folder:  
Program Files (x86)\Sommer\Commander  
Data structure:  
Users\Public\Public documents\Sommer
- Specific folder (default):  
C:\Sommer\Commander  
Data structure (default):  
C:\Sommer

6. Select the installation directory and click **Next**

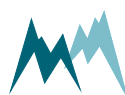
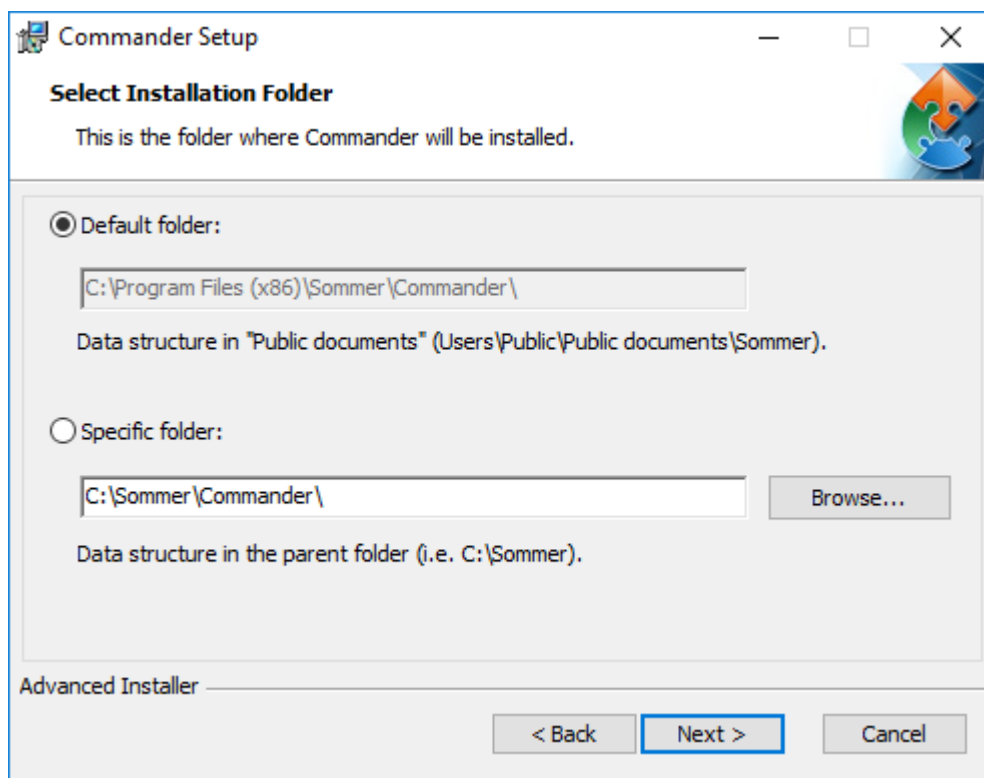

7. Select the features to be installed and click **Next**

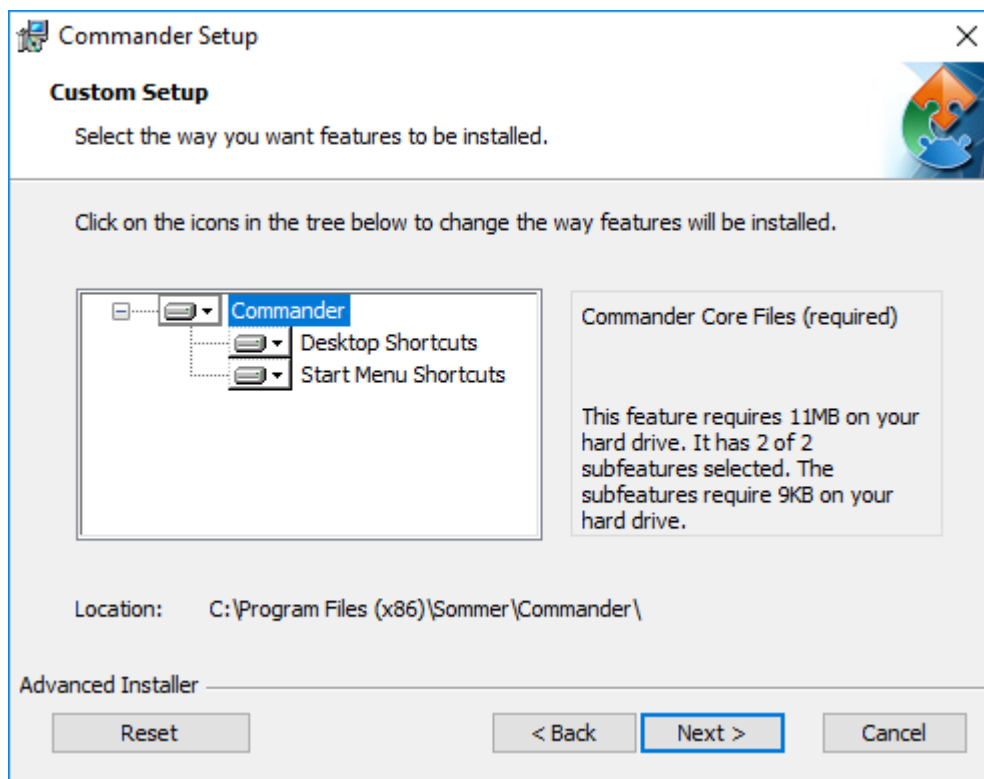

8. Click **Install** to start the installation.

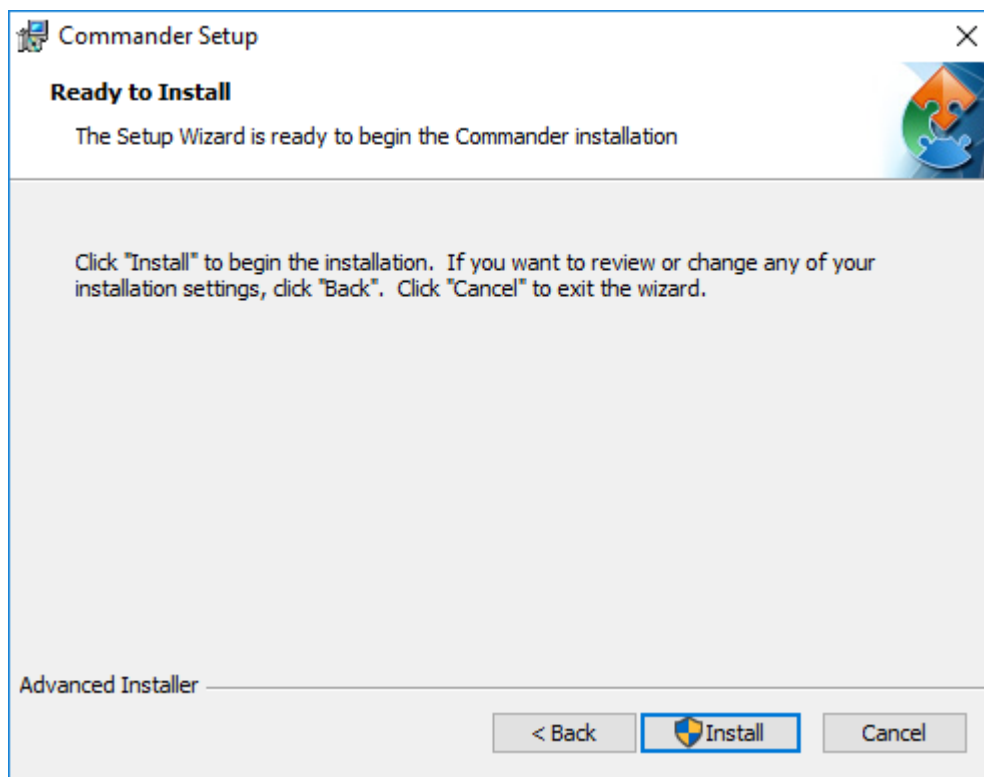

9. Click **Finish** to complete the installation.

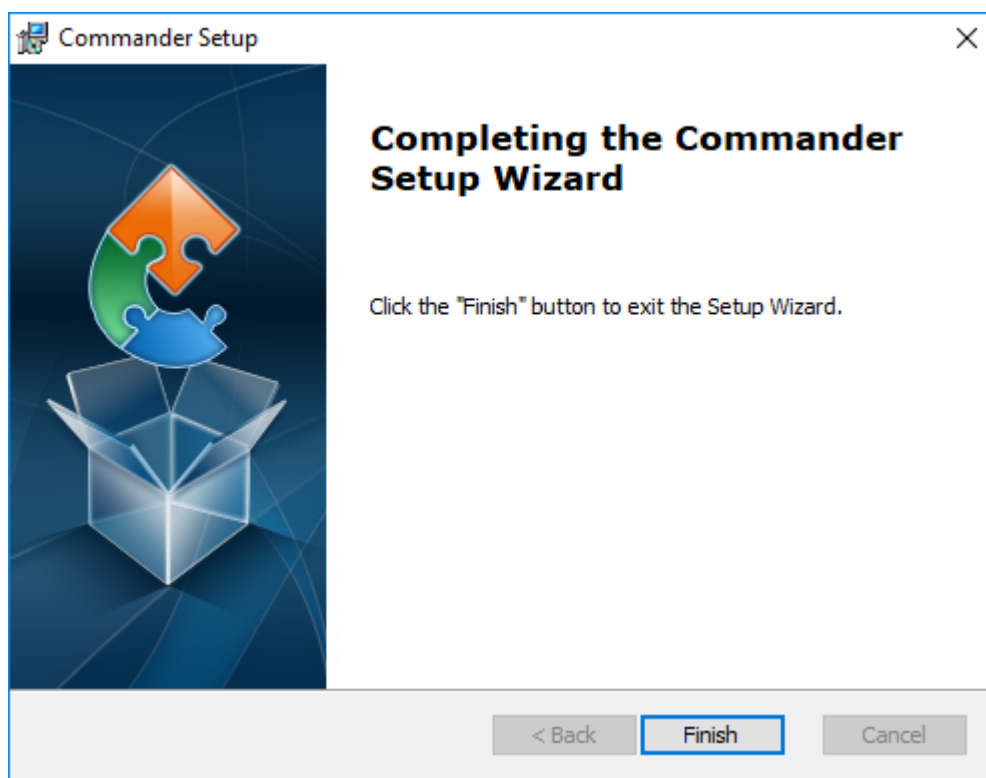

## 10.4 Change authorization

To prevent unintended changes of parameters in the **Technics** menu authorization is generally set to **Normal**. Parameter modifications in **Technics** are enabled by switching the authorization level to **Expert** as described below:

1. On the upper tab bar click on **Options** and select **Common**.
2. In the Options window select authorization **Expert** and click **OK**.

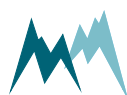
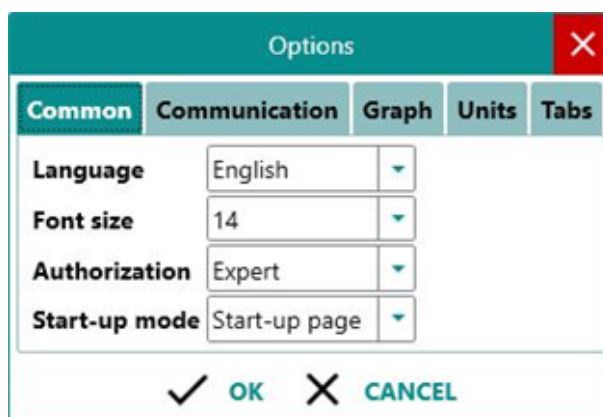

## 10.5 Working with connections

### 10.5.1 Establish a connection with the Communication assistant

1. Install the Q-Commander support software as described in [Installation of Q-Commander](#).
2. Connect the device to your PC.
3. Start the Q-Commander software on your PC.
4. Click on **Communication assistant** on the right-hand side of the Q-Commander window and follow the instructions. During this procedure the communication assistant will search for connected devices. Upon successful completion, the new connection is added to the connections list (tab **Connections (F8)**). See also pictures steps 1 to 8 in [Create a station with the Communication assistant](#).
5. In the **Communication** section at the right-hand side of the Q-Commander window select Mode **Connection** and the previously created connection from the drop-down list.
6. Click **Connect** to establish a connection with the RQ-30+. If the connection was successful a green icon is displayed at the top-right corner of the Q-Commander window.

To view the settings of the connected device or to read the current measurements, follow the steps described in [Download setup](#) and [Record measurements](#).

### 10.5.2 Establish a connection manually

1. Install the Q-Commander support software as described in [Installation of Q-Commander](#).
2. Connect the device to your PC.
3. Start the Q-Commander software on your PC.
4. Select the required connection in the **Connections** list of the **Connections (F8)** tab and click **Connect**. If the connection was successful a green icon is displayed at the top-right corner of the Q-Commander window.  
If you don't have the required connection available in the **Connections** list, create a new connection as described in [Create a new connection](#).

To view the settings of the connected device or to read the current measurements, follow the steps described in [Download setup](#) and [Record measurements](#).

### 10.5.3 Create a new connection

1. Select the **Connections (F8)** tab in the Q-Commander. If the tab is not shown, select it with pressing **F8**.

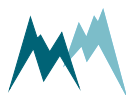

2. Click [New connection](#).
3. In the section [Connection settings](#) enter a name of the new connection, e.g. *Serial-com1-9600*, and the connection type, e.g. *Serial connection*.
4. Enter the required information for the selected connection type.  
If your RQ-30+ is wired to your PC with a RS-485 to USB converter cable, select the port where the device is connected and select a Baud rate of 9800.

## 10.6 Working with stations

### 10.6.1 Create a station with the Communication assistant

In order to manage several data loggers, to connect to a data logger via IP-call and to download data, stations can be created in the Q-Commander software. To view a list of all stations select the tab [Stations \(F7\)](#). If the tab is not shown, select it with pressing [F7](#).

Perform the following steps to create a new station with the [Communication assistant](#):

1. Click on [Communication assistant](#) in the Q-Commander-window

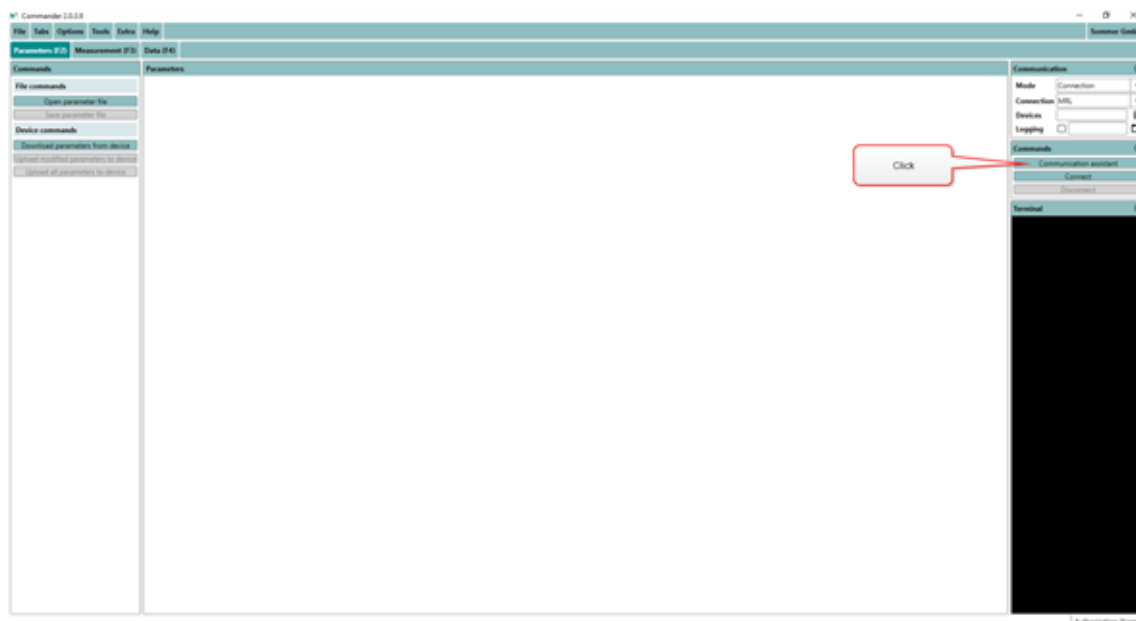

2. In the pop-up window choose the required connection and click [Next](#).

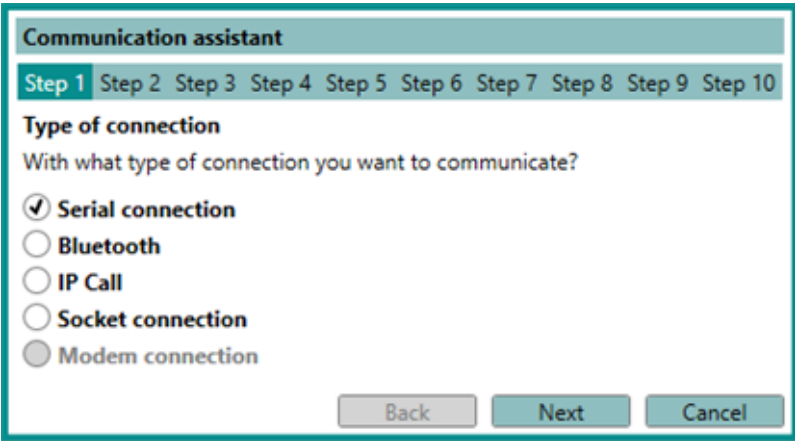

3. Verify that the RQ-30+ is connected to your PC and a power supply. Click [Next](#).



4. Select *Logger (115200 Bd)* and click [Next](#).

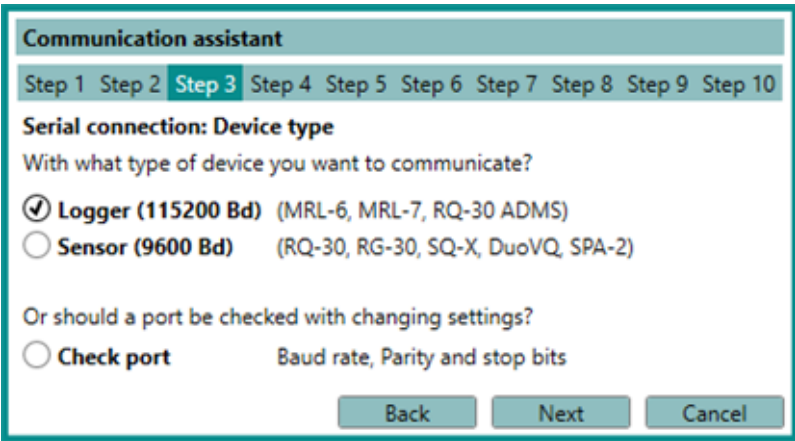

5. Select *Scan ports* and click *Next*.

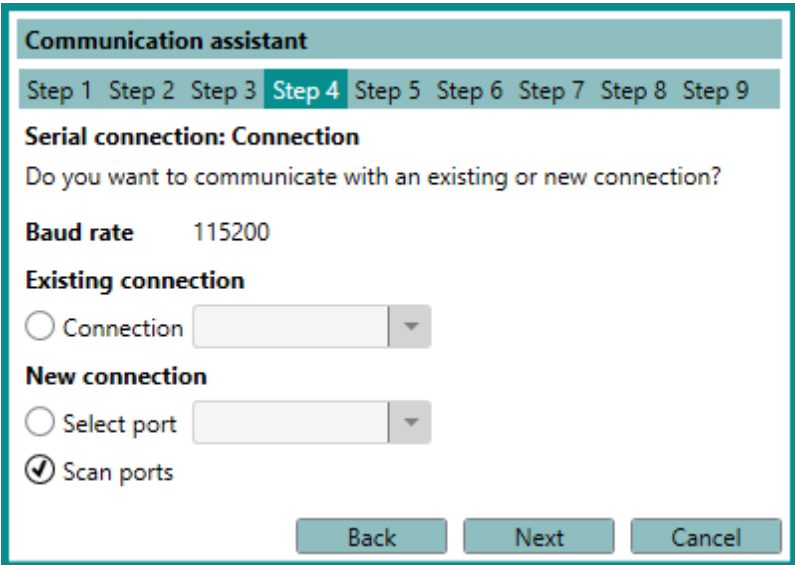

6. The Q-Commander now scans all available ports.

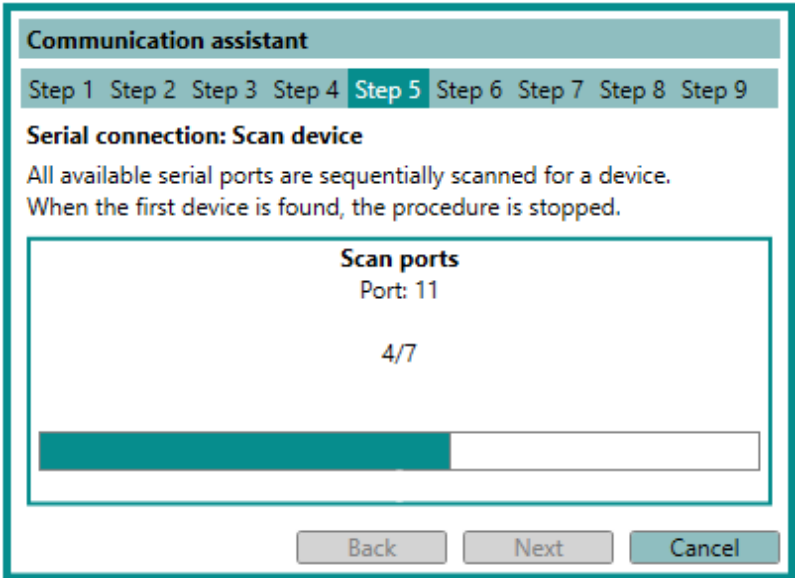

7. Adopt the *Name* provided by the communication assistant. Click **Next**.

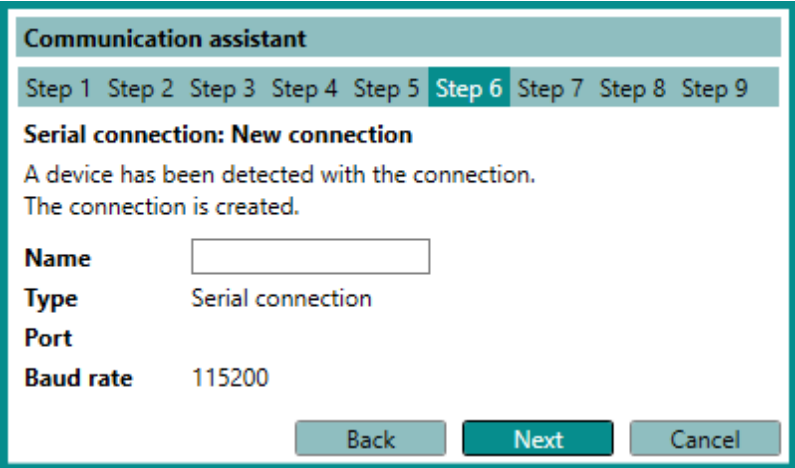

8. The Q-Commander now scans the selected port for connected devices.

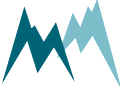
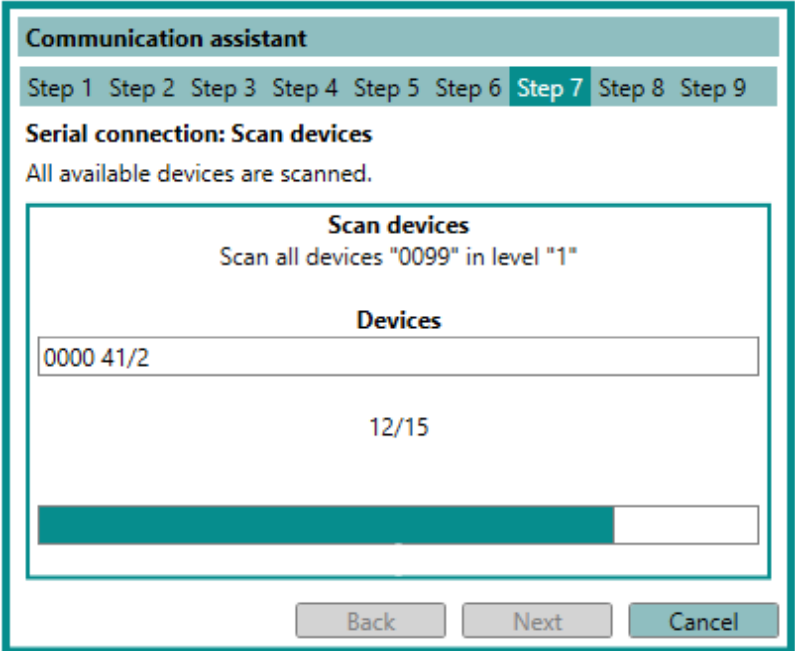

9. Adopt the *Name* of the new station or enter a new name. Click [Next](#).

**Communication assistant**

Step 1 Step 2 Step 3 Step 4 Step 5 Step 6 Step 7 **Step 8** Step 9

**New station**  
No matching station has been found.  
Changes of the station number are performed on the device as well.

**Station ID**

**Station number**

**Name**

**Devices**

**Do you want to save the station?**

10. A new station has now been created. Click [Finish](#).

**Communication assistant**

Step 1 Step 2 Step 3 Step 4 Step 5 Step 6 Step 7 Step 8 **Step 9**

**Station selected**  
The station has been selected and can now be used.

11. The newly created station can now be selected in the [Communication](#) section of the Q-Commander. Click [Connect](#) to activate the connection to your device.

## 10.6.2 Create a station manually

In order to manage several data loggers, to connect to a data logger via IP-call and to download data, stations can be created in the Q-Commander software. To view a list of all stations select the tab [Stations \(F7\)](#).

Perform the following steps to create a new station:

1. In the tab-menu [Stations \(F7\)](#) click [New station](#).
2. Under [Station settings](#) enter the [Station number](#) and [Sommer ID](#). By default both settings are set to the device's serial number (visible on the RQ-30+ housing).
3. Select the [Connections](#) used for the station. Multiple selections are possible; the default connection can be selected by ticking the circular field.

- Depending on the connection type, enter the additional information, e.g. **Address** for a Bluetooth connection or **IMSI number** for an IP call.
- Enter the settings for **Data** management. When data are downloaded from a connected RQ-30+ they are stored in an archive-file by default. Each archive-file contains the data of a year or month, as selected in **Archive type**. Selection **None** will save all data in one file. The default location for data files is C:\Users\Public\Documents\Sommer\Data\.
- Save the newly created station with the button **Save station**.

## 10.7 Working with measurements

### 10.7.1 Poll continuous measurements

- Establish a connection to your device as described in **Working with connections**.
- Download the setup of your device as described in **Download setup**.
- Select the **Measurement (F3)** tab.
- In the **Commands** section click **Start polling measurement**. Now, the Q-Commander will trigger measurements of the RQ-30+ without any delays between measurements. The results are displayed **Measurement values** and plotted in the **Measurement data graph**.
- To finish polling mode click **Stop polling**.

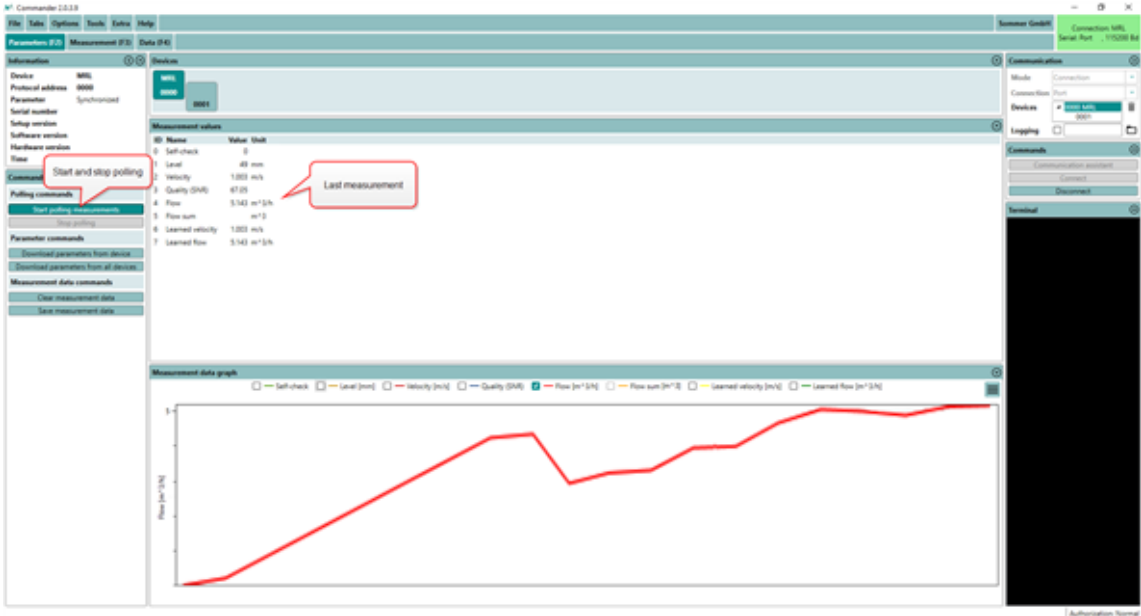

**NOTE** The polling mode stops automatically after 30 minutes.

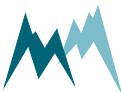

## 10.7.2 Record measurements

1. Establish a connection to your device as described in [Working with connections](#).
2. Download the setup of your device as described in [Download setup](#).
3. Select the [Measurement \(F3\)](#) tab.
4. Make sure that [Measurement output](#) is set to *Measured values push* or *Storage values push*.
5. If the connection with your device is active, the data will now be displayed in the measurement table and updated at the interval specified in the setup. Also, the incoming data strings are displayed in the [Terminal](#).
6. Click [Save measurement data](#) in the [Commands](#) section to save the recorded measurements. The data are saved as a \*.csv file in the SommerXF format.



**NOTE** You can change the scope of the data output in the setup [Information](#).

## 10.8 Working with data

### 10.8.1 View live data

Follow the steps below to view live data acquired from your device:

1. Establish a direct or remote connection with the RQ-30+ using the Q-Commander. Use an existing Q-Commander-connection or -station if available.
2. In the [Parameters \(F2\)](#) tab download the parameters of the RQ-30+.
3. Now, there are two options to view the measurement data:

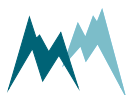

1. If **Measurement output** is set to *Measured values push* or *Storage values push*, data are displayed in the **Measurement (F3)** tab in the specified measurement interval.
2. Open the **Measurement (F3)** tab and click **Start polling measurements**. This measurement mode can be stopped by clicking **Stop polling**, or it is finished automatically after 30 minutes.

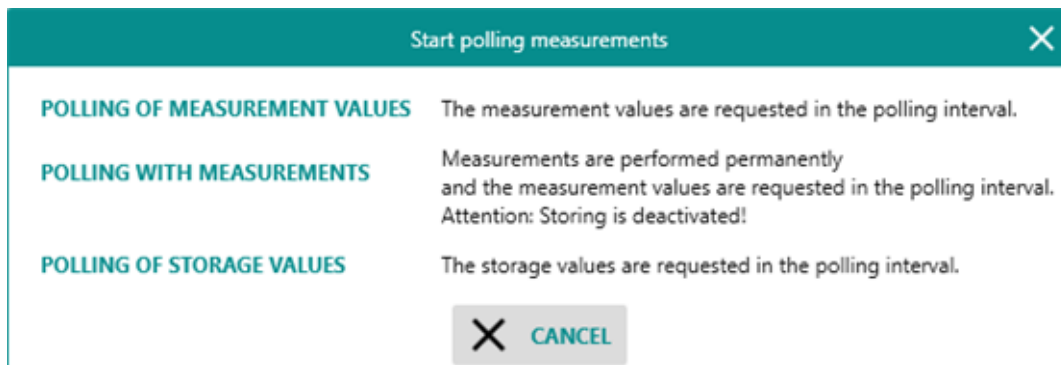

## 10.9 Working with spectra

### 10.9.1 Record spectrum

1. Establish a connection to your device as described in [Working with connections](#).
2. Download the setup of your device as described in [Download setup](#).
3. Select the **Measurement (F3)** tab.
4. Click **Start spectrum mode** in the **Commands** section. Now the Q-Commander collects the spectrum data and displays them in **Spectrum graph**.



**NOTE** The collection of the spectrum data may require some time.

5. Click **Save spectrum file** in the **Commands** section to save the recorded spectra. The data are saved as a \*.xlms file.



**NOTE** The number of acquired spectra is displayed at the bottom of the **Spectrum graph**. You can navigate through the spectra by clicking the navigation buttons.

6. Click **Stop spectrum mode** to quit recording spectra.

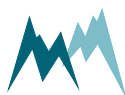

## 10.9.2 Read spectrum file

1. Open the Q-Commander.
2. Click [Open spectrum file](#) in the [Commands](#) section.
3. Select the desired spectrum file (\*.xmls) and click [Open](#). The spectra are now opened and displayed in the [Spectrum graph](#).



**NOTE** The number of acquired spectra is displayed at the bottom of the [Spectrum graph](#). You can navigate through the spectra by clicking the navigation buttons.

## 10.10 Working with setups

### 10.10.1 Download setup

1. Establish a connection to your device as described in [Working with connections](#).
2. Select the [Parameters \(F2\)](#) tab in the Q-Commander software.
3. In the [Commands](#) section click [Download parameters from device](#).

The Q-Commander now downloads the setup currently active on the RQ-30+. This may take some time if you are downloading the setup for the first time to your PC. Consecutive downloads of a setup with the same version number will be faster as the parameter structure is already available.

You can now save the setup file by clicking [Save parameter file](#), or edit the settings as described in [Edit setup](#).



**TIP** Save the setup on your PC before you make any changes!

### 10.10.2 Open a setup file

1. Start the Q-Commander on your PC and connect to your RQ-30+ either directly with the USB to RS232 isolated converter cable or, if available, the optional Bluetooth connection.
2. Open the [Parameters \(F2\)](#) tab and click [Open parameter file](#). Select the required file (extension .xmld or .xmla).

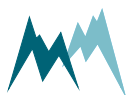

### 10.10.3 Edit setup

1. Open the setup file as described in [Open a setup file](#) or download it from your device as described in [Download setup](#).
2. Adapt the values of the settings in question and press Enter after each. After you have changed a value, its text box will turn red.



**NOTE** If you have entered a value outside the data range of the setting, it will be forced to the next valid value! The valid range of each setting is listed in the [Parameter definitions](#).

3. After you have adapted all required settings save the setup file and/or upload the setup to your device by clicking [Upload modified parameters to device](#).  
Once the setup has been saved or uploaded, the modified red text boxes will turn white again, indicating that the settings have been saved/applied.

### 10.10.4 Upload new setup file

1. Establish a connection to your device as described in [Working with connections](#).
2. Select the [Parameters \(F2\)](#) tab.
3. Download the setup currently on the RQ-30+ as described in [Download setup](#) and save it by clicking [Save parameter file](#). This step is recommended to have the latest setup available for documentation.
4. Click [Open parameter file](#) and select the required setup file (\*.xlm) on your PC.
5. Click [Upload all parameters to device](#). This transfers the current setup to the RQ-30+.
6. To verify the correct upload click [Download parameters from device](#). This will display the present setup of the RQ-30+.

## 10.11 Update firmware

1. Connect the RQ-30+ to your PC with the USB to RS485 isolated converter cable.
2. Make sure no connection is active in the Q-Commander (no green icon at the top-right corner).
3. Click on the menu item [Extra](#) and select [Start Programmer](#).
4. Select the firmware file (\*.hex) provided by SOMMER Messtechnik. Make sure the file is stored on your PC and not on a USB or network drive.
5. Choose the COM-port the data logger is connected to and a Baud-rate of 57'600.
6. Perform the following three steps in short sequence:

- Click **Program**
- Unpower the data logger
- Wait 3...5 seconds to enable full activation of the bootloader and a correct restart (capacitors must be discharged, and if the device had been in sleep mode, this can take some time)
- Repower the data logger

The firmware currently present on the data logger is now erased and the new one copied to the data logger. During the update process the pop-up window may show the following messages:

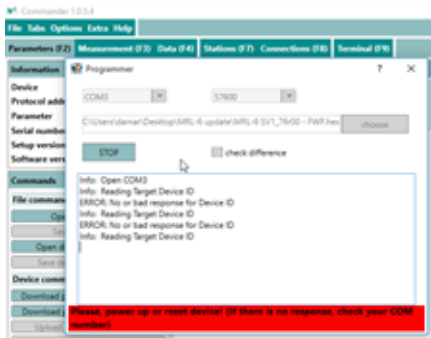

The device is not ready; power needs to be on.

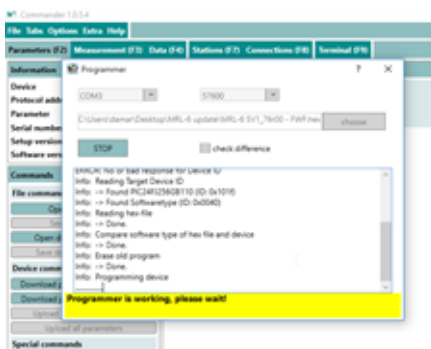

The programmer is active.



The firmware update has finished.

7. Close the programmer-window as soon as the firmware update has finished.
8. Switch off and repower the data logger again.
9. Open the **Parameters (F2)** tab.

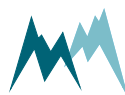

10. Click [Download parameters from device](#). The download of the new parameter list might take a few minutes as the parameter structure may need to be downloaded as well. After completion the new firmware and setup versions will be displayed in the [Information](#) section.

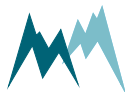

# 11 Configuration of the RQ-30+

## 11.1 Software tools

The RQ-30+ can be configured with one of the following tools:

- Configuration with Q-Commander support software
- Configuration with a terminal program

## 11.2 Configuration with Q-Commander support software

Follow the steps below to modify the configuration parameters of the RQ-30+:

1. Establish a connection between your PC and the RQ-30+.
2. Click [Download parameters from device](#). The complete parameter list is transferred from the RQ-30+ to your PC and displayed in the Parameter window.

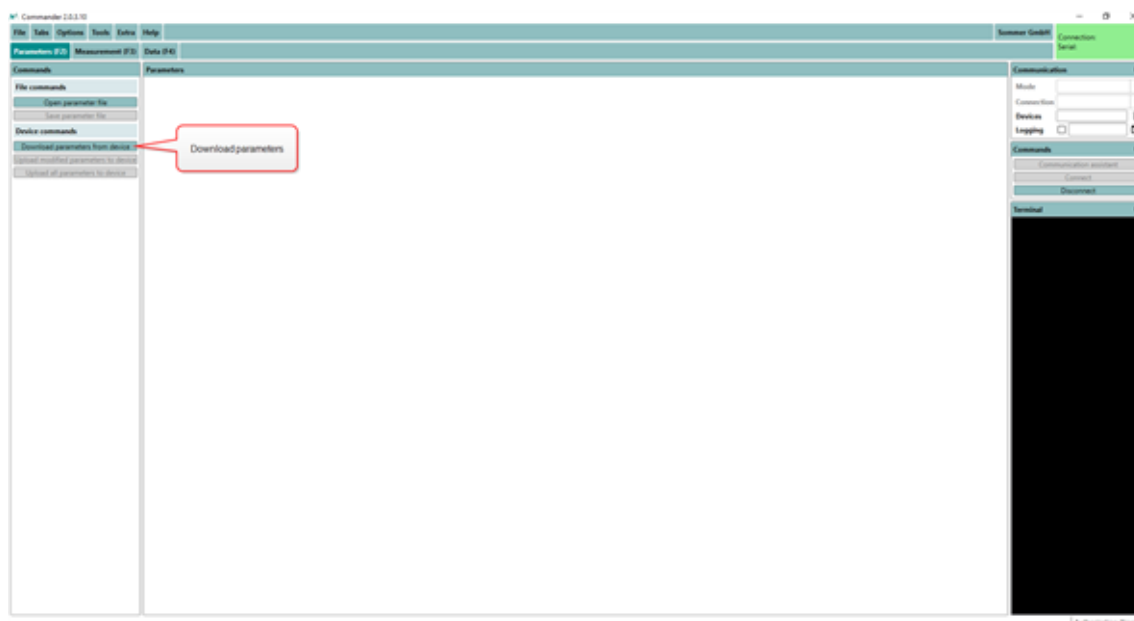



**NOTE** The first download of the parameter list may take a few minutes. After that the device is known to the PC and consecutive downloads are much faster.

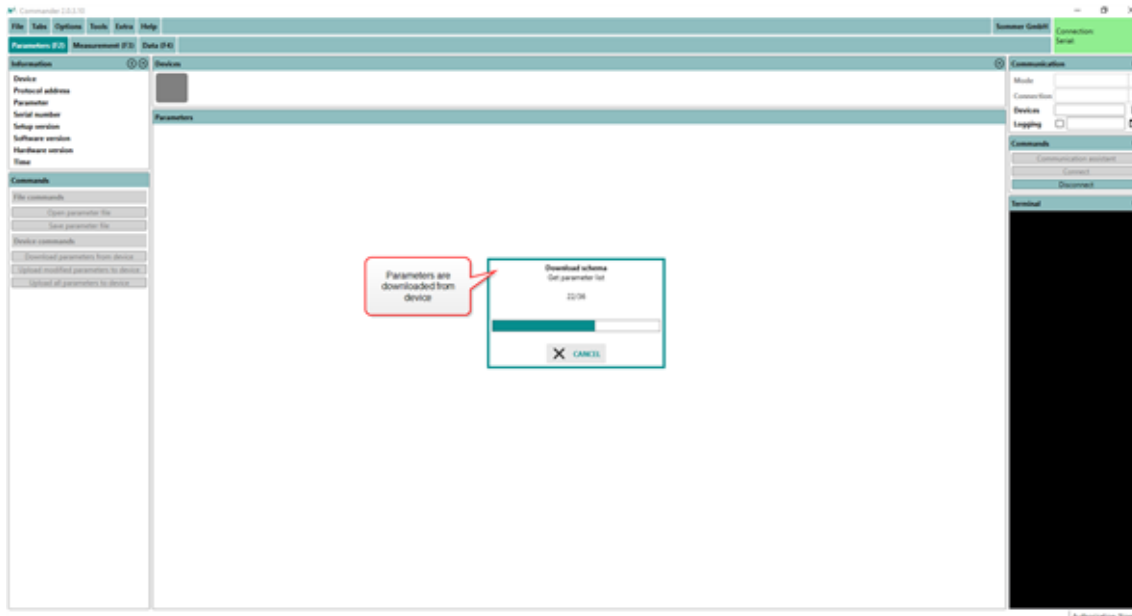

3. Save the parameter file to your PC by clicking **Save parameter file**. This step is recommended to track any configuration changes.

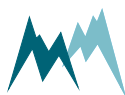
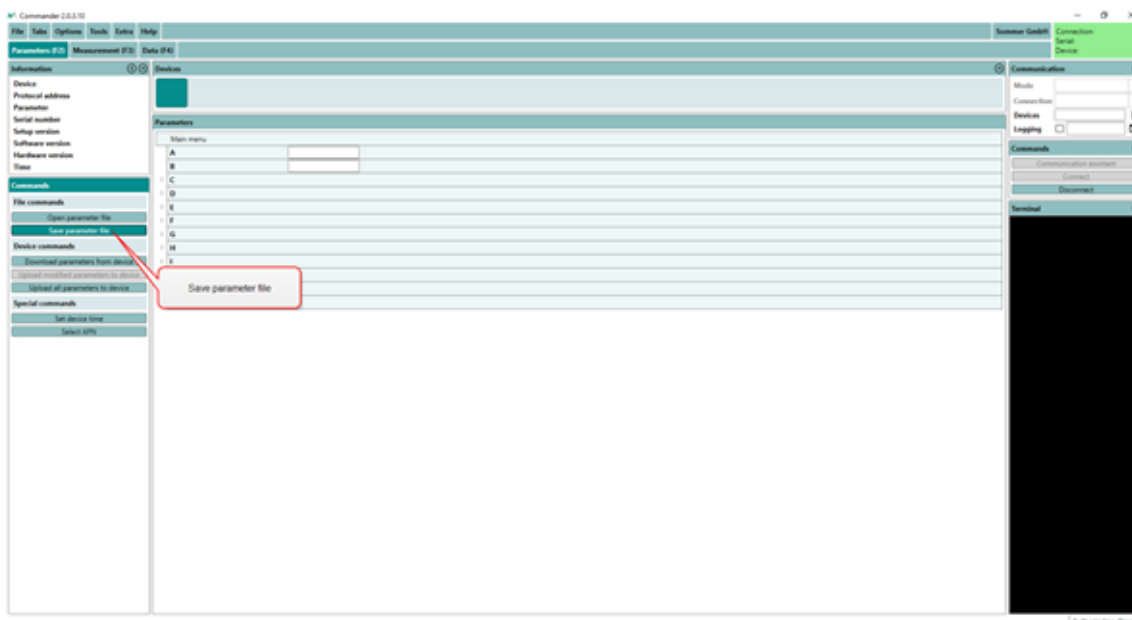

- Adapt the parameters required for your application. Changed values are displayed with a pink background.

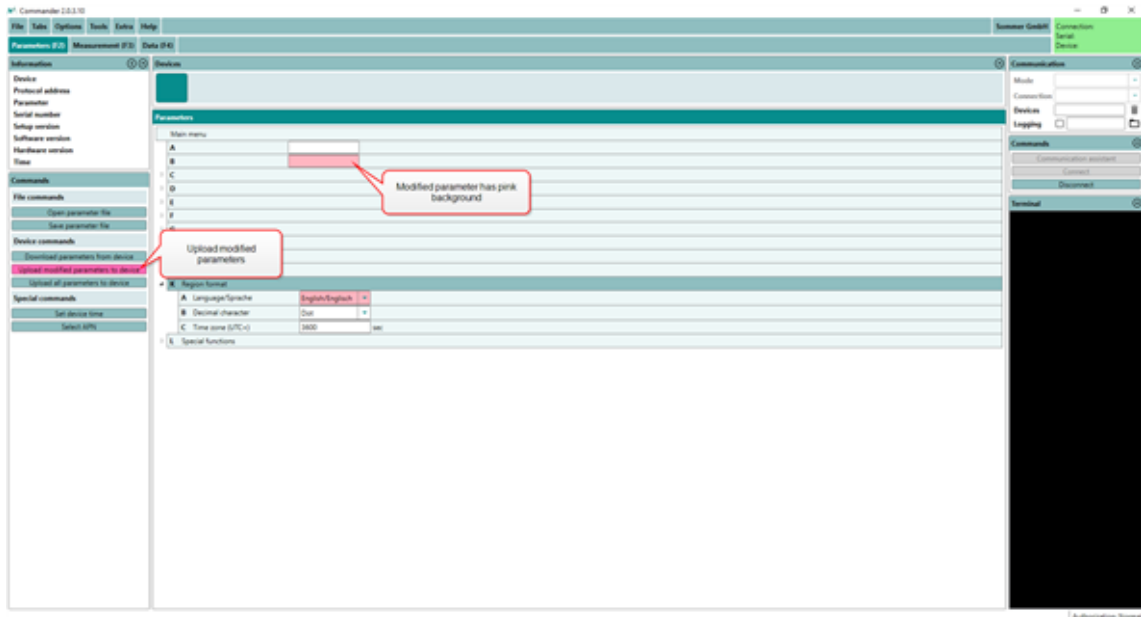

- Send the modifications to the RQ-30+ by clicking **Upload modified parameters to device**. Upon successful upload the pink backgrounds disappear again.

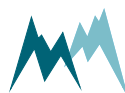

## 11.3 Configuration with a terminal program

The Q-Commander software ships with an integrated terminal program. However, communication with the RQ-30+ can be performed with any terminal program.

Follow the steps below to modify the configuration parameters of the RQ-30+:

1. Establish a connection between your PC and the RQ-30+.
2. In the terminal window enter three question marks (???) in quick succession. The main parameter menu is displayed in response.

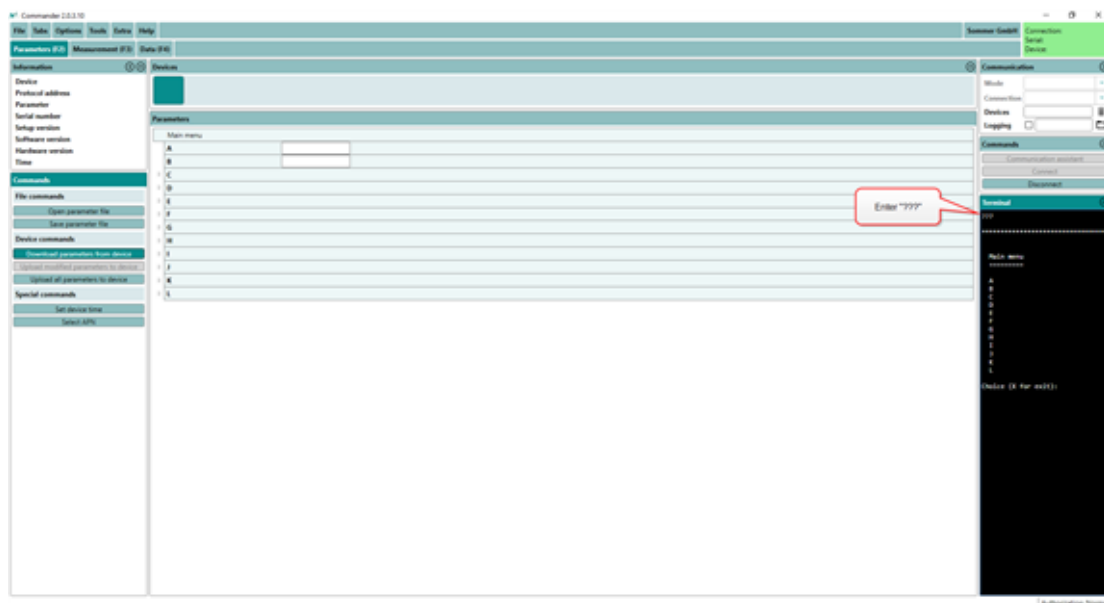

**NOTE** As an unwanted switching into the menu mode must be avoided the timing of the three question marks ??? is very restrictive and must never be finished with Return/Enter. This is especially important for command line tools, which automatically send a closing "Carriage return". Before and after sending ??? no communication must occur for 1 second.

3. Read or modify the required parameters: The menu items can be selected by entering the letter assigned to each item. Upon selection a submenu is opened or the selected parameter is displayed with its unit. Changes to values are confirmed with **Return/Enter** or discarded with **Esc**. Menus are closed with **X** or **Esc**. After closing the main menu with **X** the device performs an initialization.

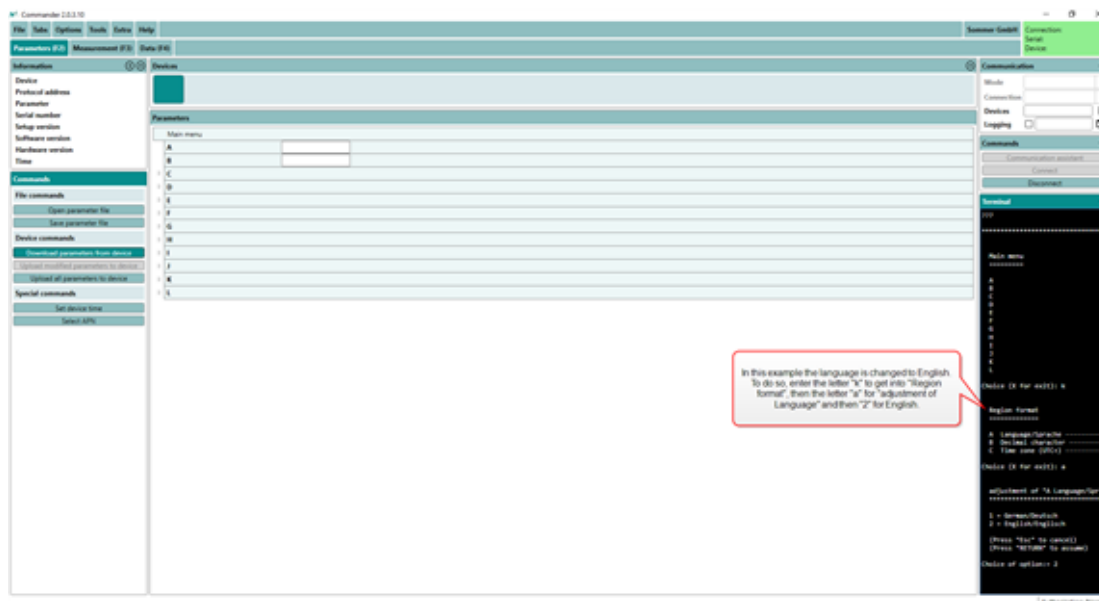

## 11.4 Conflict messages

During configuration with the Q-Commander software, the RQ-30+ may return conflict messages after one or more parameters have been changed and uploaded to the device.



**ATTENTION** If a conflict occurs, invalid settings are replaced automatically with valid values. Verify the values of the conflicting parameters and adapt them if needed!

### 11.4.1 Setup conflicts

A setup conflict message as listed below is returned if a modified setup with conflicting parameters is loaded onto the RQ-30+.

Conflict code	Parameter	Comment
0001	AUX, Status	Conflict with a hidden parameter. Please contact Sommer Messtechnik for advice.
0002	Measurement output	Set to <i>just per command</i> if Protocol type is set to <i>Modbus</i> .
0010	River inclination	Set to 0 if Possible flow directions is set to <i>two (tide)</i> .
0020	WLL, low level border WCF, cease to flow level	The water level parameters should respect the rule: WMA > WLL > WCF. If the specified levels violate this rule, they are adapted to the next valid value.
0040	Maximum velocity	Set to 5 m/s if value is $\geq 30$ m/s or $< 1.5$ m/s.
0080	Minimum velocity	Set to 25% of Maximum velocity if $> 25\%$ of Maximum velocity. Set to 0.01 m/s if Maximum velocity is below 0.01 m/s.

Table 3 Setup conflict messages

## 11.5 General settings

When first setting-up a RQ-30+ at a measurement site, the parameters described below may need to be adapted.

### 11.5.1 Measurement trigger

Measurements are initiated by one of the options listed in the table below.

The commands to trigger measurements via RS-485 and SDI-12 are described in [Communication](#).

Measured data are either returned directly after the measurement or can be requested by commands via the RS-485 or SDI-12 interface. The format of the returned data can be configured in the sub-menu [Protocol type](#).

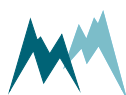

ID	Option	Description
1	Interval (default)	Measurements are initiated in a specified interval.
2	TRIG input	Measurements are triggered by the positive edge of a DC-voltage signal applied to the TRIG input (low: 0 ... 0.6 V, high: 2.2 ... 28 V, pulse duration must be $\geq 500$ ms, delay between pulses must be $\geq 500$ ms)
3	SDI-12/RS-485	Measurements are externally triggered by commands via RS-485 or SDI-12 from ,e.g. a data logger.
4	all allowed	Measurement is triggered by all options mentioned above.

An internal measurement interval can be set for the RQ-30+. If selected in menu item [Measurement trigger](#), measurements are performed in the defined interval. However, a measurement is always completed before a new one is initiated.

### 11.5.2 Language/Sprache

The menu language.

### 11.5.3 Decimal character

The character used as decimal separator in the values of the settings, in serial data strings and in .csv files.

### 11.5.4 Units and decimals

The units and number of decimal digits. These have to be set prior to all other settings as all values are saved internally in this format. They are set in the parameter menu [Units and decimals](#).



**ATTENTION** If units or decimals are changed, related parameters may need to be adjusted.

### 11.5.5 Protocol type

The type of the serial output protocol. The following options are available:

ID	Option	Description
1	Sommer new (SBP)	Sommer Bus Protocol (SBP); data values are returned with an index starting at 1. Multiple strings may be returned.
2	Standard	Standard protocol; data values are returned without an index in one string.
6	MODBUS	Modbus protocol
7	Sommer old (SBP) (default)	Sommer Bus Protocol (SBP); data values are returned with an index starting at 0. Multiple strings may be returned.

### 11.5.6 Information

The main measurement values are always included in the data output string. Additionally, special and analysis values can be included.

ID	Option	Description
1	Main values	Only the main values are returned.
2	& Special values (default)	Main values and special values are returned.
3	& Analysis values	Main, special and analysis values are returned.

## 11.6 Water level measurement

The settings for the water level measurement are defined under [Level \(W\)](#) and [Tech. level \(W\)](#).



**ATTENTION** Do not start the RQ-30+ while the target surface is within the blanking distance of the level sensor! Otherwise the RQ-30+ will not receive level measurements for several minutes! See for the blanking distance of your sensor.

### 11.6.1 WMA, maximum level

The maximum expected water level (see [Figure 18](#)). It represents the upper limit of the W-v relation and is required for W-v learning.

### 11.6.2 WLL, low level border

The water level below which velocity measurements are not feasible (see Figure 18). It represents the lower limit of the W-v relation. A guidance value is 5 cm above the river bed or any protruding stones in the measurement area.



**ATTENTION** Below the low level border no velocity measurement is performed any more.

### 11.6.3 WCF, cease to flow level

The water level at which the flow velocity is always zero (see Figure 18).

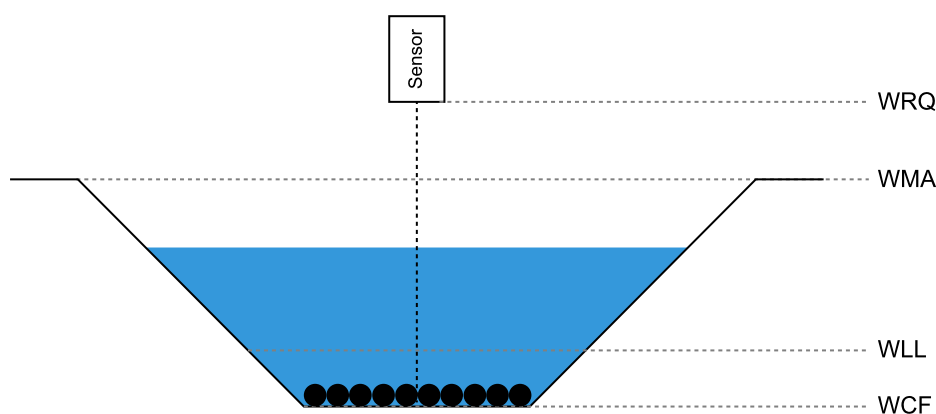

Figure 18 Designation of water levels

### 11.6.4 Adjustment

The most important setting for water level and discharge measurements is the level adjustment. It is essential that the measured water level  $W$  is referenced to the levels in the cross-sectional profile and the discharge table .

The procedure to adjust the level is different for sites with and without existing water level measurements.

### 11.6.4.1 Adjustment with known water level

The adjustment with an existing water level measurement is simple as the actual water level is known. However, it is essential that the gauge zero GZ of the existing water level measurement is defined as the reference level for the discharge table.

The water level measurement of the RQ-30+ sensor is set to the known value by the following steps:

1. Click the button [Adjustment](#) in the parameters list. This initiates a water level measurement and the measured level is displayed.
2. Enter the water level of the existing measurement. After confirmation the water level measurement of the RQ-30+ sensor is adjusted to the given value and the entry for the mounting height is updated.

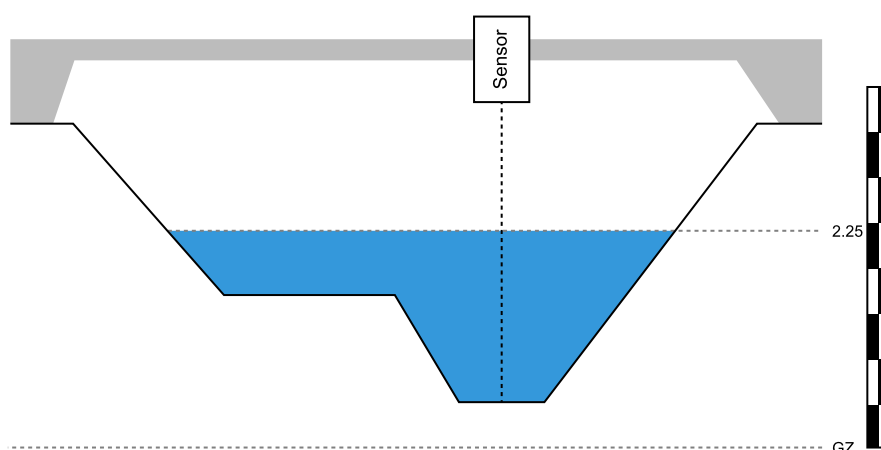

Figure 19 Water level adjustment with known water level

### 11.6.4.2 Adjustment with unknown water level

If the water level at the measurement site is not known, the mounting height of the RQ-30+ sensor  $W_Q$  can be set directly. To do this, the exact vertical position of the RQ-30+ sensor in the reference coordinate system must be determined.

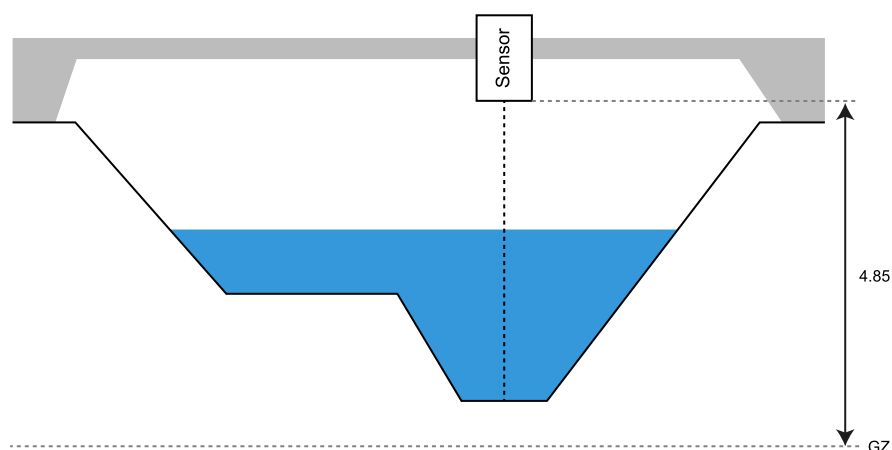

Figure 20 Water level adjustment by setting of the mounting level  $W_Q$  of the RQ-30+

### 11.6.4.3 Setting of the special water levels

The velocity measurement might be obstructed at low water levels. If the level drops below WLL, the velocity measurement is stopped to avoid erroneous measurements. However, the water level measurement is still performed and the discharge is determined by interpolating the velocity between WLL and WCF. The velocity at WLL is calculated from the  $W-v$  relation.

## 11.7 Velocity measurement

The measurement of the flow velocity depends on the mounting position of the RQ-30+ sensor and the water flow conditions at the site. These conditions are defined by the settings under [Velocity](#) and [Tech. velocity \(v\)](#)

### 11.7.1 Viewing direction

The viewing direction of the RQ-30+ sensor in relation to the flow direction of the river, either *upstream* or *downstream*.

### 11.7.2 Possible flow directions

The setting to define if the river only flows in one direction or if two flow directions can occur, e.g. under tidal influence (see also [Flow direction separation](#)).

### 11.7.3 Measurement duration

The duration of a single measurement. During this time the velocity radar signal is recorded and the radar spectrum is calculated. Generally, a measurement duration of 30 s is recommended. For very calm rivers a longer measurement duration should be selected.

### 11.7.4 Minimum velocity

The minimum expected velocity. No lower velocities are considered.

### 11.7.5 Maximum velocity

The maximum expected velocity. The velocity measurement is optimized for this setting. Usually a value of 5 m/s is adequate.

### 11.7.6 Meas. spot optimization

The expected velocity distribution in the measurement spot. The more irregular the distribution, the wider the selected spectral band width used for the velocity measurement.

For the first measurements at a new site the option *standard* is recommended. Later on, the measurement may be optimized by selecting another option.

### 11.7.7 Measurement type

The velocity measurement can either be performed continuously in one block, or in a sequence of five consecutive blocks with breaks in between. The sequenced method is more representative but slower. By default the selection should be set to *continuous*.

### 11.7.8 Criteria for invalid measurements and their handling

Velocity measurements can be defined as invalid by the criteria quality (SNR) and opposite direction content (*Stop, min. quality (SNR)* to *Stop, replace value*). These criteria and the handling of invalid measurements are controlled with these settings. Please refer to *Tech. velocity (v)* for details.

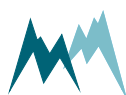

### 11.7.9 Inclination measurement

As described in [Inclination angle measurement](#) each velocity measurement has to be corrected for sensor inclination. If the RQ-30+ sensor is mounted stably it is sufficient to measure the installation angle with the first measurement after a sensor restart. If the sensor can move it is recommended to perform an inclination measurement with each velocity measurement.

### 11.7.10 View spectral distribution

With this function the RQ-30+ radar sensor is switched into spectrum mode and the spectra are recorded by the Q-Commander and displayed in the [Measurement](#) tab. Please refer to [Radar spectrum](#) for more details on velocity radar spectra.

## 11.8 Discharge table

To calculate the discharge from water level and velocity measurements, a discharge table is required. This table is generated during the site survey .

The discharge table can be edited directly in the parameter menu [Discharge table](#) or uploaded to the RQ-30+ sensor via the Profile tab of the Q-Commander software.

## 11.9 Total discharge volume

The RQ-30+ offers the function to totalize the measured discharge rate and return it as a discharge sum.

The discharge sum can be reset to a user defined value, usually zero, with the Q-Commander function [Set total discharge volume](#).

## 11.10 W-v relation

Generally, water level  $W$  and flow velocity  $v$  are related. If this relationship is assumed to be stable discharge rates can be deduced from water level measurements only. This functionality is implemented in the RQ-30+ sensor as  $W$ - $v$  learning, which means that the sensor continuously adjusts an internally stored  $W$ - $v$  curve with each new measurement.

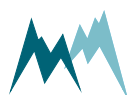

### 11.10.1 Usage

The W-v relation can be used to smooth velocity measurements and discharge rates. Generally, the water level fluctuates only slightly while the flow velocity can vary considerably depending on the flow conditions. By applying the learned W-v relation to the water level measurements velocity and discharge data can be smoothed.

Additionally, the W-v relation is used to interpolate flow velocities for water levels between the low level border WLL and the cease to flow level WCF as shown in [Figure 21](#). Such conditions occur if stones impair the velocity measurement or if the sensor points to dry areas. For these low water levels the velocities can be interpolated from the W-v relation and thus provide valid velocity and discharge values.



**ATTENTION** If no stable W-v relation is present at the measurement site the learned W-v relation will provide unstable results as well.

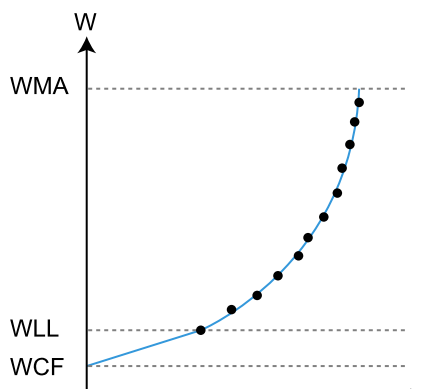

Figure 21 Interpolation of the flow velocity between WLL and WCF

### 11.10.2 Learning of the W-v relation

For the water level range between the maximum level WMA and the low level border WLL a table with 16 value pairs consisting of water levels and learned velocities is created. The learned velocities in the table are continuously adjusted with each new measurement. With time, the complete water level range is covered with learned velocities and a relatively stable relation between water level and velocity is generated, provided the measurement site allows this. Consequently, for each measured water level a learned velocity and a learned discharge can be assigned by linear interpolation.



**ATTENTION** The time needed to generate a complete W-v learning curve strongly depends on the fluctuations of the water level at the measurement site.

### 11.10.3 Water levels for the W-v relation

The range of water level, in which the W-v relation is learned, is defined by the special water levels WMA, WLL and WCF (see [Water level measurement](#)).

### 11.10.4 Activation

Usage of the W-v relation is activated as soon as one of the special water levels WMA, WLL or WCF is different from zero.

### 11.10.5 W-v priority

By default the W-v priority is set to *no* and the measured velocity and discharge are returned as main values. The learned velocity and discharge are returned as special values.

If the W-v priority is set to *yes* the learned velocity and discharge are returned as main values. The measured velocity and discharge are returned as special values.

### 11.10.6 W-v table reset

With this function the existing W-v table is deleted and the W-v learning starts anew. This is required if any of the special water levels WMA, WLL or WCF have changed or if the RQ-30+ sensor is moved to an-other measurement site.

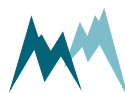

# 12 Communication

## 12.1 Communication protocols

The RQ-30+ provides the following communication protocols:

- [RS-485](#) (Sommer Bus Protocol)
- [Modbus](#)
- [SDI-12](#)

## 12.2 Data output

### 12.2.1 Main values

The main values comprise the primary measurement values as listed below and are always returned with the data string. Units and decimal places can be set in [Units and decimals](#).

Index	Measurement value	Unit	Description
01	AUX	-	Only if <a href="#">Status</a> of <a href="#">Tech. AUX</a> is <i>on</i> . Measurement value of the auxiliary sensor
01	Self-check	-	Only if <a href="#">Status</a> of <a href="#">Tech. AUX</a> is <i>off</i> . ID of self-check function (see <a href="#">Device status</a> )
02	Water level	2	Measured water level
03		1	Measured velocity
04	Quality (SNR)	-	Quality value containing SNR
05	Discharge <sup>1</sup>	2	Measured discharge
06	Area	2	Cross sectional area
09	Opposite direction	%	Only if <a href="#">Status</a> of <a href="#">Total discharge volume</a> is <i>off</i> (default)
09	Discharge sum	2	Only if <a href="#">Status</a> of <a href="#">Total discharge volume</a> is <i>on</i>

<sup>1</sup>Unit according to sub-menu [Units and decimals](#)

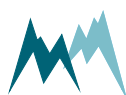

Table 4 Main values

## 12.2.2 Special values

The special values comprise the learned velocity and discharge as well as some diagnostic values (see 12.2.2).

Index	Measurement value	Unit	Description
10	Supply voltage	V	Voltage of the power supply input

Table 5 Special values

## 12.2.3 Analysis values

The analysis values as listed in 12.2.3 comprise diagnostic information of the velocity measurement.

Index	Measurement value	Unit	Description
11	Peak width	mm/s	Band width of the signal
12	CSR	%	Corrected intensity
13	Area of the peak	-	-
14	RMS at the PIC	mV	Diagnostic variable
15	Amplification	-	Value of the amplification regulation
16	Amplification relation	%	Diagnostic variable
17	Signal relation	%	Diagnostic variable
18	Error code	-	for diagnostic use of Sommer Messtechnik only
19	not used	-	-
20	not used	-	-
21	not used	-	-

Table 6 Analysis values

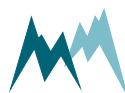

## 12.2.4 Quality value

The quality value provides information about the velocity measurement and distribution and has the format: -21.89

	Description
-	Validity of the measurement
21	SNR in dB
8	Amplification, 0...9
9	Band width class, 0...9

### L.2.4.1 Validity of the measurement

Measurements with a negative quality value have been identified as invalid (so-called stop measurements).

A velocity measurement is flagged invalid if the opposite direction content exceeds the threshold defined in [Stop, max. opp. direction](#) or if the quality value is below the [Stop, min. quality \(SNR\)](#) limit.

### L.2.4.2 SNR

The Signal-to-Noise Ratio contains the most important information of the quality value. Generally, a SNR lower than 30 indicates an insufficient flow velocity measurement.

### L.2.4.3 Amplification

Depending on the condition of the water surface, e.g. waves, and the distance between water surface and sensor the received radar signals may fluctuate considerably. To compensate for these fluctuations the radar signal is amplified accordingly.

A high amplification value indicates a weak radar signal; a value of 0 is optimal.

### L.2.4.4 Band width class

The band width class depends on the spectral velocity distribution. Generally, a high band width corresponds to a turbulent river, i.e. *Splash water*, a low band width to a calm river, i.e. *consistent*. This

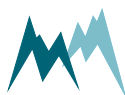

classification may not be very accurate. Observations of the flow conditions at the measurement site always have to be considered.

## 12.2.5 Exception values

Measurement data may be returned with the following exception values:

Value	Description
99999998	Initial value: No measurement has been performed yet.
99999997	Conversion error: Caused by a technical problem.
99999999	Positive overflow
-99999999	Negative overflow

Table 7 Exception values

## 12.3 RS-485

### 12.3.1 What is RS-485?

RS-485 is a serial communication method for computers and devices. It is currently a widely used communication interface in data acquisition and control applications where multiple nodes communicate with each other.<sup>1</sup>

### 12.3.2 What can I do with it?

RS-485 communication is primarily used to trigger measurements and read their results. It also permits to change parameters of the RQ-30+.

### 12.3.3 Configuration

The RQ-30+ has serial RS-485 communication enabled by default. If the device is integrated into a RS-485 network or connected to a stand-alone data acquisition system, e.g. a data logger, the parameters listed in [RS-485 \(COM\)](#) may need to be adapted.

<sup>1</sup><https://www.lammertbies.nl/comm/info/RS-485.html>

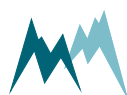

### 12.3.3.1 System key and device number

The system key and device number are used to identify a RQ-30+ in a bus system. This is essential if multiple devices (RQ-30+ and data loggers) are operated within the same system.

#### System key

The system key separates different conceptual bus systems. This may be necessary if the remote radio coverage of two measurement systems overlap. In wired setups, the system key should be set to *00*.

#### Device number

The device number is a unique number that identifies a device in a bus system.



**ATTENTION** Do not use a device number twice in your bus system! Otherwise communication will fail!

### 12.3.3.2 Measurement output

The serial data output can be triggered in the following ways:

ID	Option	Description
1	Just per command	The output is only requested by commands via RS-485.
2	After measurement (default)	The serial data output is performed automatically right after each measurement.
3	Pos. TRIG slope	The output is triggered by a positive edge of a control signal applied to the trigger input.



**NOTE** If **Measurement output** is set to *pos. TRIG slope*, the data are returned with a delay of 200 ms after the trigger has been set. Make sure that your data acquisition system takes account of this lag to ensure that it receives the most recent data.

### 12.3.3.3 Operation modes

The selected combination of measurement trigger and output time determines the following operation modes:



Parameter	Mode		
	Pushing	Polling	Apparent polling
Measurement trigger	internal	TRIG input SDI-12/RS485	TRIG input SDI-12/RS485
OP, measurement output	after measurement	just per command	after measurement

### 12.3.3.4 Waking-up a connected data logger

The RQ-30+ supports wake-up of a connected data logger that is in standby mode. Generally, this feature is only used in pushing and can be set under [Wake-up sequence](#).

#### 12.3.3.4.1 Sync sequence

The sync sequence is the string `UU~?~?` and is sent directly before a command. It is used to synchronize the receiving UART.

#### 12.3.3.4.2 Prefix

The prefix is an arbitrary character; the RQ-30+ uses a blank. This character is sent prior to any communication. Then the time of the [Prefix holdback](#) is waited and the command is sent afterwards. With this procedure the receiving device has time to wake-up.

### 12.3.3.5 Output protocols

For data output via RS-485 different protocols are available, which can be selected under [Protocol type](#).

## 12.3.4 Data output options

Data are returned in two different formats, selectable in [Protocol type](#):

- [Sommer Bus Protocol \(SBP\)](#)
- [Standard protocol](#)
- [Sommer old protocol](#)

## 12.3.5 Sommer Bus Protocol (SBP)

The data string of the Sommer Bus Protocol has the following format:





**EXAMPLE** #M0001G01se01 1461|02 1539|03 25.25|04  
0|ADC9;

A data string contains max. 8 values and is max. 105 characters long.

### 12.3.5.1 Header

The header (#M0001G01se) identifies the data by system key, device number and string number.

Parameter	Format	Description
Start character	#	
Identifier	M	M identifies an output string
System key	dd	
Device number	dd	
Command ID	G	G defines an output string with string number
String number	dd	01 Main values 03 Special values 05 Analysis values 06 Analysis values
Command	se	se identifies automatically sent values

Table 8 Header of the Sommer Bus Protocol

### 12.3.5.2 Measurement value

A measurement value (02 1539|) has a length of 8 digits and is returned together with its index. If the measurement value is a floating point number, one digit is reserved for the decimal character. Values are returned right-aligned, so blanks may occur between index and value.

Parameter	Format	Description
Index	dd	2 numbers
Value	xxxxxxxx	8 character right-aligned
Separator		

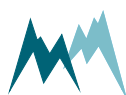

Table 9 Values in Sommer Bus Protocol

### 12.3.5.3 End sequence

The data string is terminated with a CRC-16 in hex format (ADC9) followed by an end character and <CR><LF>. The CRC-16 is described in [Sommer Messtechnik CRC-16](#).

Parameter	Format	Description
CRC-16	hhhh	4-digit hex number
End character	;	
Control characters	<CR><LF>	Carriage return and Line feed

Table 10 End sequence of the Sommer Bus Protocol

### 12.3.5.4 Example Sommer Bus Protocol

#### 12.3.5.4.1 Main values

Main values are returned as in the following example:

 **EXAMPLE** #M0001G00se01 -17.4|02 8806|03 0.433|04  
40.93|05 0.00|06 5.36|59DF;

#M0001G00se	Header with system key 00, device number 01 and string number 00
01 -17.4	AUX
02 8806	Water level
03 0.433	Flow Velocity <sup>1</sup>
04 40.93	Quality (SNR) (see <a href="#">Quality value</a> )
05 0.00	Discharge <sup>1</sup>

<sup>1</sup>The positions of the measured and learned velocity and discharge can be switched with the menu item [W-v priority](#).

06	5.36	Area
59DF;		Closing sequence

Table 11 Main values in Sommer Bus Protocol

#### 12.3.5.4.2 Special values

Special values are returned as in the following example:

	<b>EXAMPLE</b> #M0001G01se07	0.000 08	0.00 09	46 10	15.13 E30C;
---	------------------------------	----------	---------	-------	-------------

#M0001G01se	Header with system key 00, device number 01 and string number 01	
07	0.000	Learned velocity <sup>1</sup>
08	0.00	Learned discharge <sup>1</sup>
09	46	Opposite direction content
10	15.13	Supply voltage
E30C;	Closing sequence	

Table 12 Special values in Sommer Bus Protocol

#### 12.3.5.4.3 Analysis values

Analysis values are returned as in the following example:

	<b>EXAMPLE</b>	#M0001G02se11	430 12	293 13	78 14	116 15	11075 16	-40 E08D;
		#M0001G03se17	0 18	0 19	9999998 20	9999998 21	9999998 3827;	

#M0001G02se	Header with system key 00, device number 01 and string number 02 for the analysis values 11 to 16	
11	430	Peak width [mm/s]

12	293	CSR [%]
13	78	Area of the peak
14	116	RMS at the PIC
15	11075	Amplification
16	-40	Amplification relation [%]
E08D ;		Closing sequence
#M0001G03se		Header with system key 00, device number 01 and string number 03 for the analysis values 17 to 21
17	0	Signal relation [%]
18	0	Error code
19	9999998	not used
20	9999998	not used
21	9999998	not used
3827 ;		Closing sequence

Table 13 Analysis values in Sommer Bus Protocol

## 12.3.6 Standard protocol

The data string of the Standard protocol has the following format:

	<b>EXAMPLE</b>	M_0001	1461	1539	25.25	0
---	----------------	--------	------	------	-------	---

### 12.3.6.1 Header

The header (M\_0001) identifies the data by system key and device number.

Parameter	Format	Description
Identifier	X_	M_ Measurement values S_ Special values V_ Analysis values
System key	Dd	
Device number	Dd	

Table 14 Header of the Standard protocol

### 12.3.6.2 Measurement values

Measurement values are returned in sequence and are separated by a blank. A measurement value has a length of 8 digits. If the measurement value is a decimal number, one digit is reserved for the decimal character. Values are returned right-aligned, so additional blanks may be returned between values.

Parameter	Format	Description
Separator	[blank]	blank
Value	xxxxxxxx	8 character right-aligned

Table 15 Values in Standard protocol



**NOTE** With the standard protocol the data strings can be very long. In contrast, the strings of the Sommer Bus Protocol are max. 105 characters long.

### 12.3.6.3 End sequence

The data string is terminated with <CR><LF>.

### 12.3.6.4 Example Standard protocol

#### 12.3.6.4.1 Main and special values

Main and special values are returned as in the following example:

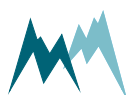

✓	<b>EXAMPLE</b>	M_0001	-17.4	6458	0.679	35.93
		0.00	5.36	0.679	0.00	46
		15.13				

<b>M_0001</b>	Header with identifier for measurement values
<b>-17.4</b>	No value assigned, always 99999998
<b>6458</b>	Water level
<b>0.679</b>	Velocity <sup>1</sup>
<b>35.93</b>	Quality (SNR) (see <a href="#">Quality value</a> )
<b>0.00</b>	Discharge1
<b>5.36</b>	Area
<b>0.679</b>	learned velocity <sup>1</sup>
<b>0.00</b>	learned discharge <sup>1</sup>
<b>46</b>	Opposite direction content
<b>15.13</b>	Supply voltage

Table 16 Main and Special values in Standard protocol

#### 12.3.6.4.2 Analysis values

Analysis values are returned as in the following example:

✓	<b>EXAMPLE</b>	z_0001	664	239	61	91
		11075	47	0	200	9999998
		9999998;				9999998

<b>z_0001</b>	Header with identifier for analysis values
<b>664</b>	Peak width [mm/s]

<sup>1</sup>The positions of the measured and learned velocity and discharge can be switched with the menu item [W-v priority](#).

239	CSR [%]
61	Area of the peak
91	RMS at the PIC
11075	Amplification
47	Amplification relation [%]
0	Signal relation [%]
200	Error code
9999998	not used
9999998	not used
9999998	not used

Table 17 Analysis values in Standard protocol

### 12.3.7 Sommer old protocol

The data string of the Sommer old protocol has the following format:

 **EXAMPLE** #M0001G00se00 -17.4|01 0.535|02 0.000|03  
-1.89|04 0.0|05 0|B11D;

This protocol is identical with the Sommer Bus Protocol except that the index of the measurement values starts at 0 instead of 1.

This protocol has been implemented for compatibility reasons: When a Sommer Messtechnik device with firmware < 2.0 is updated to version 2.x the protocol is automatically set to Sommer old. Thus, the setup of a connected data logger does not have to be adjusted.

### 12.3.8 RS-485 commands

### 12.3.8.1 Command structure

The structure of serial commands and answers is described in the following table:

Parameter	Format	Description
Start character	#	
Identifier	X	<p>W Write: RQ-30+ returns a confirmation on receipt. This command type demands a closing sequence with a valid CRC-16.</p> <p>S Silent: RQ-30+ does not acknowledge the receipt of the command. This command type demands no closing sequence and therefore no CRC-16.</p> <p>R Read: RQ-30+ returns the requested measurement value or parameter. This command type demands a closing sequence with a valid CRC-16.</p> <p>T Temporary: Write a volatile, temporary setting and receive a confirmation.</p> <p>A Answer: Answer of device to read or write command.</p>
System key	dd	
Device number	dd	
Command	xxx	See table in section <a href="#">Commands</a> .
Separator		
CRC-16	hhhh	4-digit hex number
End character	;	

Table 18 Structure of Sommer Bus Protocol commands and answers

### 12.3.8.2 Commands

The following commands can be used with the RQ-30+:

Command	Description
\$mt	Trigger a measurement
\$pt	Return measurement values
XX	Read a parameter with identifier XX
XX=xxxx	Write a parameter with identifier XX and the value xxx

Table 19 List of Sommer Bus Protocol commands

### 12.3.8.3 Trigger a measurement

The command \$mt triggers a complete measurement sequence as in the following example:

 **EXAMPLE** #W0001\$mt|BE85;      Answer: #A0001ok\$mt|4FA9;

### 12.3.8.4 Read a parameter value

Read measurement interval (in the example below the menu item B):

 **EXAMPLE** #R0001B|228B;      Answer: #A0001B=300|F8B3;

### 12.3.8.5 Request a complete data string

The command \$pt requests a data string as in the following example:

 **EXAMPLE**  
**Option 1**  
#W0001\$pt|7D19;      Answer: #A0001ok\$pt|8C35;  
**Option 2**

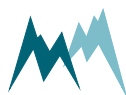



#S0001\$pt|

Answer: none

The data string is returned as soon as the RQ-30+ has processed the command. If a wrong command is entered, the device returns #A0001na\$pt|3D40;.

### 12.3.8.6 Request a single measurement value

The reading command R together with the index of the requested measurement returns a single measurement value. In the following example the measurement value with index 01 is requested:



#### EXAMPLE

##### Measurement Value cv:

```
#R0001_010cv|EA62; Answer: #A0001ok_010cv1461 |5D62;
```

##### Storage Value sv:

```
#R0001_010sv|F853; Answer: #A0001ok_010sv1461 |1D31;
```

## 12.3.9 Sommer Messtechnik CRC-16

The CRC-16 (cyclic redundancy check) used in data transmission of Sommer Messtechnik devices is based on the ZMODEM protocol. When data are exchanged between two devices the receiving device calculates the CRC-value. This value is compared to the CRC value sent by the other device to check if the data were transmitted correctly. Please refer to technical literature or contact Sommer Messtechnik for calculation of CRC-16 values.

You can [here](#) calculate the CRC of a command online .

If you need to compute CRCs automatically, you can implement the following procedure in your data logger or controller software.

The CRC-16 is calculated character by character. The start value for the initial CRC-16 calculation is always 0.

The following procedure returns the CRC-16 of a single character:

```
byte1 = CRC-16 right shift by 8 bits           upper byte disappears
uint1 = c                                     new character, upper byte = 0
uint2 = CRC-16 left shift by 8 bits           lower byte = 0
uint3 = crcl6tab[byte1]                       Table value from the CRC-16 table
Crc16 = uint3 (excl. or) uint2 (excl. or) uint1
```

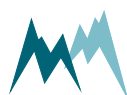

### Computation CRC-16 in C/C++

```
1 | crc16 = crc16tab[(unsigned char)(crc16>>8)] ^ (crc16<<8) ^ (unsigned int)(c);
```

The `crc16tab` array is listed in [CRC-16 array](#).



#### EXAMPLE

Command to request measurement data `#W0001$pt|7D19;`

The first character is `#`, the last `|`. The CRC-16 of the command is `7D19` and its end character is `;`.

The CRC-16 is calculated sequentially with the start value `0` for the initial CRC-16 calculation:

Position	String	CRC-16
Start		0000
0	#	0023
1	#W	2357
2	#W0	4331
3	#W00	4997
4	#W000	4EDD
5	#W0001	743B
6	#W0001\$	0537
7	#W0001\$p	67D5
8	#W0001\$pt	C935
9	#W0001\$pt	7D19

## 12.4 SDI-12

### 12.4.1 What is SDI-12?

SDI-12 (Serial Data Interface at 1200 Baud) is a serial data communication standard for interfacing multiple sensors with a single data recorder. For a detailed description on SDI-12 communication please refer to [www.sdi-12.org](http://www.sdi-12.org).



## 12.4.2 What can I do with it?

The RQ-30+ listens to standard SDI-12 commands as listed in the SDI-12 specifications of version 1.3, e.g., to trigger a measurement or retrieve measurement results. Additionally, a set of extended SDI-12 commands is implemented in all SOMMER sensors for instrument configuration.

## 12.4.3 Configuration

The RQ-30+ has SDI-12 communication enabled by default. When setting up a SDI-12 network take the following considerations into account:

- Each device in the SDI-12 network must have a unique address, e.g. data logger address *0*, RQ-30+ address *1*.
- If the RQ-30+ operates in polling mode (**Measurement trigger** set to *SDI-12/RS-485*), measurements are triggered by *M!* commands and data are retrieved by *D!* commands.
- If the RQ-30+ operates in pushing mode (**Measurement trigger** set to *interval*), data are retrieved by the *R!* commands.
- When multiple sensors are connected to the same network, data acquisition should be done in sequence, i.e., data should have been received from the first sensor before triggering the measurement of the second sensor.
- Most data loggers control the timing of messages (marking and spacing) automatically. If this is not the case, please refer to [www.sdi-12.org](http://www.sdi-12.org).

## 12.4.4 Data structure

The answer from the SDI-12 device is a string containing the sensor address, the requested data and a terminating carriage return/line feed.

In a string containing measurement data, the measurements are returned in the same order as listed by the index in [Data output](#).



### EXAMPLE

```
0+2591+706+25.53+62<CR><LF>
```

Value	Content
0	Sensor address
2591	Measurement with index 01
706	Measurement with index 02
25.53	Measurement with index 03

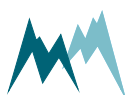



Value	Content
62	Measurement with index 04

If a device returns more than 9 measurement values, or if the values are returned in groups (see also [Request results](#)) the measurement index increments in the next group.

**EXAMPLE**

0D0!      Answer: 0+2591+706+25.53+62<CR><LF>

0D0!      Answer: 0+56.2+125+12.32<CR><LF>

Value	Content
0	Sensor address
2591	Measurement with index 01
706	Measurement with index 02
25.53	Measurement with index 03
62	Measurement with index 04
0	Sensor address
56.2	Measurement with index 05
125	Measurement with index 06
12.32	Measurement with index 07

### 12.4.5 SDI-12 commands

The following tasks can be performed with standard and extended SDI-12 commands.

Extended SDI-12 commands are non-standard commands implemented by SOMMER to enable device configuration via SDI-12.



**NOTE** After any changes, the settings have to be adopted with the command `aXW_ts|!`, with `a` the sensor address.

### 12.4.5.1 Command structure

A standard SDI-12 command starts with the sensor address and ends with an exclamation mark, e.g., 0M! to trigger a measurement.

Configuration commands contain additional information; see the sections below for details.

### 12.4.5.2 Identify device

The identification of a SDI-12 device is requested with the command aI!, with a the sensor address.



#### EXAMPLE

0I!            Answer 013Sommer    USH    140r90 USH-9            <CR><LF>

The answer contains the following information:

0	SDI-12 address
1	SDI-12 version prior to the point
3	SDI-12 version after the point
Sommer	Description of the company (6 characters and 2 blanks)
USH	Description of the firmware (5 characters and 2 blanks)
140r90	Firmware version (6 characters and 2 blanks)
RQ-30+	Device designation (max. 13 characters)

### 12.4.5.3 Acquire measurements

To acquire a measurement from a sensor, two individual SDI-12 commands – trigger a measurement and request measurement values – need to be sent.



#### EXAMPLE

0M!            Answer: 00084<CR><LF>    and    0<CR><LF>    after 8 seconds

0D0!           Answer: 0+2591+706+25.53+0<CR><LF>

The first values in the response to the aDn! command is the sensor address.

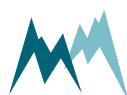

#### 12.4.5.4 Trigger measurement

The command `aM!` with sensor address `a` triggers a measurement as in the example below.

The response states the measurement duration and the number of measurement values (see example below). After completion of the measurement, the device will return an additional `a<CR><LF>`, with `a` the sensor address.



##### EXAMPLE

`0M!` Answer: `00084<CR><LF>` and `0<CR><LF>` after 8 seconds

The answer contains the following information:

<code>0</code>	SDI-12 address
<code>008</code>	Duration of the measurement in seconds
<code>4</code>	Number of measurement values

#### 12.4.5.5 Request results

After each measurement, results are requested with the command `aDn!`, with `a` the sensor address and `n` the index of the returned data string.



**EXAMPLE** `0D0!` Answer: `0+2591+706+25.53+0<CR><LF>`

The leading `0` of the response is the sensor address.

Generally, the command `aD0!` is sufficient to request up to 9 measurement values. If more than 9 values need to be read, or if the values are returned in groups, the commands `aD1!`, `aD2!`,... may need to be issued after `aD0!`. For example, if a measurement returns 8 values in two groups of 4, the commands `aD0!` and `aD1!` need to be issued to receive all values.

#### 12.4.5.6 Acquire continuous measurements

If the SDI-12 device is operating in continuous measurement mode (not polled by SDI-12), the command `aR0!` will request and return the current reading of the sensor. The values within the data string follow the order listed in the measurement table. The first values in the response to the `aRn!` command is the sensor address.

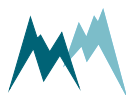

**EXAMPLE**

0R0!      Answer: 0+2591+706+25.53+0<CR><LF>

**ATTENTION**

If more than 8 values need to be read, or if the values are returned in groups, the commands aR1!, aR2!,... may need to be issued after aR0!. For example, if a measurement returns 8 values in two groups of 4, the commands aR0! and aR1! need to be issued to receive all values.

**12.4.5.7 Configure parameter**

The configuration parameters of a SOMMER sensor are read with the command aXRpp! and written with the command aXWpp=vvv!, with a the sensor address, pp the parameter identifier and vvv the value of the parameter.

**12.4.5.8 Read and write a parameter****EXAMPLE**

Reading of measurement interval (in this example menu item B)

0XRB|!      Answer: 0B=300|<CR><LF>

Setting of measurement interval to 60 s (in this example menu item B)

0XWB=60|!      Answer: 0B=60|<CR><LF>

**12.4.5.9 Read and write a selector-parameter**

Changing the measurement trigger (in the following example menu item A) from *interval* to *SDI-12/RS485*:

**EXAMPLE**

0XRA|!      Answer: 0A=1|<CR><LF>

0XWA=3|!      Answer: 0A=3|<CR><LF>

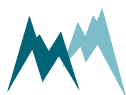

### 12.4.5.10 Read and write a parameters of a table

Some SOMMER sensors are equipped with multiple transducers and their settings are listed in a table (see example below). A value within such a table is addressed by its row-index (01, 02 ...) and column-index (A, B ...). A corresponding SDI-command has the following format:



#### EXAMPLE

In this example of a snow scale the value in row 01 and column B of the parameter D-D-E is changed to -1.4.

0XWDDE01B=-1.4|!

Answer: 0DDE01b=-1.4|<CR><LF>

	Identifier	offset zero kg	gain	zero default kg	gain default
01	Load Cell 1	-1.4	0,997787	0,000	0,997787
02	Load Cell 2	0,000	0,997787	0,000	0,997787
03	Load Cell 3	0,000	0,997787	0,000	0,997787
04	Load Cell 4	0,000	0,997787	0,000	0,997787

### 12.4.5.11 Adopt settings

Some settings need to be adopted with the command `aXW_ts|!`, with `a` the sensor address. It is recommended to issue `aXW_ts|!` after each configuration change.

## 12.5 Modbus

### 12.5.1 What is Modbus?

Modbus is a serial communication protocol used for transmitting information over serial lines between electronic devices. The device requesting the information is called the Modbus Master and the devices supplying information are Modbus Slaves. In a standard Modbus network, there is one Master and up to 247 Slaves, each with a unique Slave Address from 1 to 247. The Master can also write information to Slaves.

Modbus has become a standard communication protocol in industry, and is now the most commonly available means of connecting industrial electronic devices. It is often used to connect a supervisory

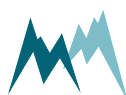

computer with a remote terminal unit (RTU) in supervisory control and data acquisition (SCADA) systems. Versions of the Modbus protocol exist for serial lines (Modbus RTU and Modbus ASCII) and for Ethernet (Modbus TCP).<sup>1</sup>

## 12.5.2 What can I do with it?

Modbus-communication with RQ-30+ allows reading of measurement values and device information by a Modbus master. Additionally, the basic RS-485 port settings can be written to the RQ-30+.

## 12.5.3 Wiring

For Modbus communication the RQ-30+ is wired according to the table below.

Modbus	Connector MAIN	Connection wire	Description
Common		White	GND
Vsupply		Brown	9...30 VDC
D1 - B/B		Yellow	RS-485 A
D0 - A/A		Grey	RS-485 B

Table 20 Modbus wiring



### NOTE

Please note that different signal notations are in use for RS-485 connections:

TX+/RX+ or D+ or D1 as alternative for B

TX-/RX- or D- or D0 as alternative for A



**NOTE** If the RQ-30+ is operated with multiple Modbus devices within the same network, termination resistors may be required. Please contact Sommer Messtechnik for details.

<sup>1</sup><http://www.simplymodbus.ca/FAQ.htm>

## 12.5.4 Modbus configuration

Follow the instructions below to change the communication of a Sommer Messtechnik device (in this example a RG-30) to Modbus:

1. Connect the USB to RS-485 converter to the data cable of the Sommer Messtechnik device and a USB port on your PC.
2. Connect the sensor to a power supply with the specified rating.
3. Start the Q-Commander software on your PC.
4. Establish a connection to the Sommer Messtechnik device.
5. Download the sensor's parameters in the **Parameters (F2)** tab and save the parameter list on your PC.

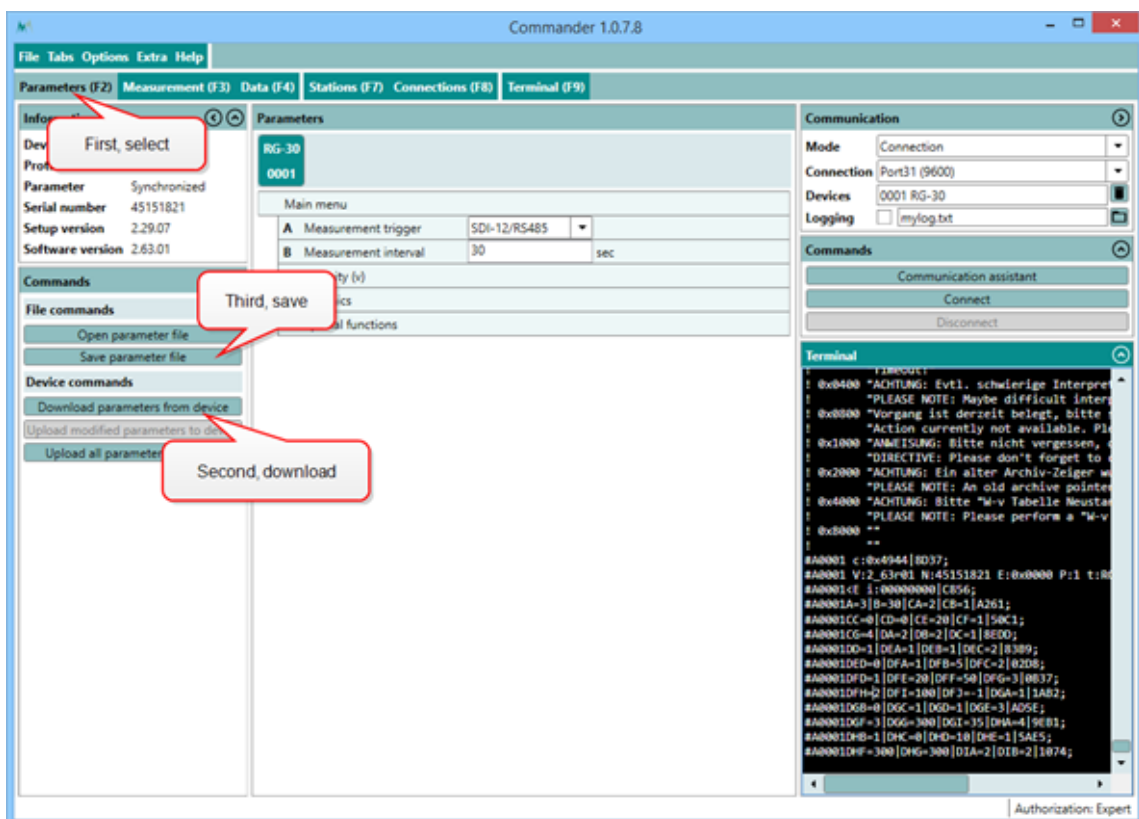

6. In the parameter list navigate to Technics and open the menus **RS-485 protocol** and **RS485** and take a screenshot of the associated parameters. This and the previous step are helpful if you need to switch back to the standard communication mode at a later time.

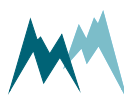

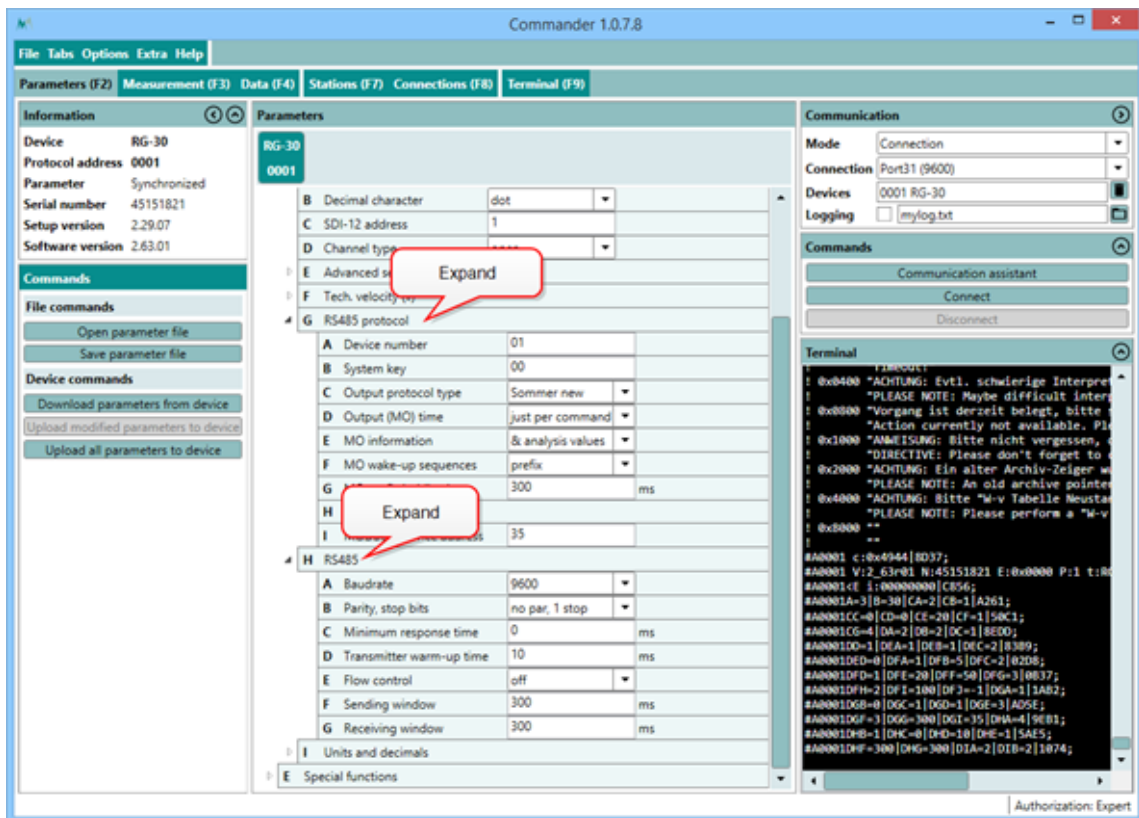

7. Set **Measurement trigger** to one of the following options:
  - A. *Interval*, if measurements are triggered internally by the device.
  - B. *SDI-12/RS-485*, if measurements are triggered by SDI-12.
  - C. *TRIG input*, if measurements are triggered by a trigger input.
  - D. *all allowed*, if measurements are triggered by one of the previous options.



**NOTE** Modbus cannot trigger measurements! Make sure to use the trigger option suitable for your application!

8. Verify that the connection to the Sommer Messtechnik device is active and click into the Terminal window. Type `???` to enter the sensor-menu.

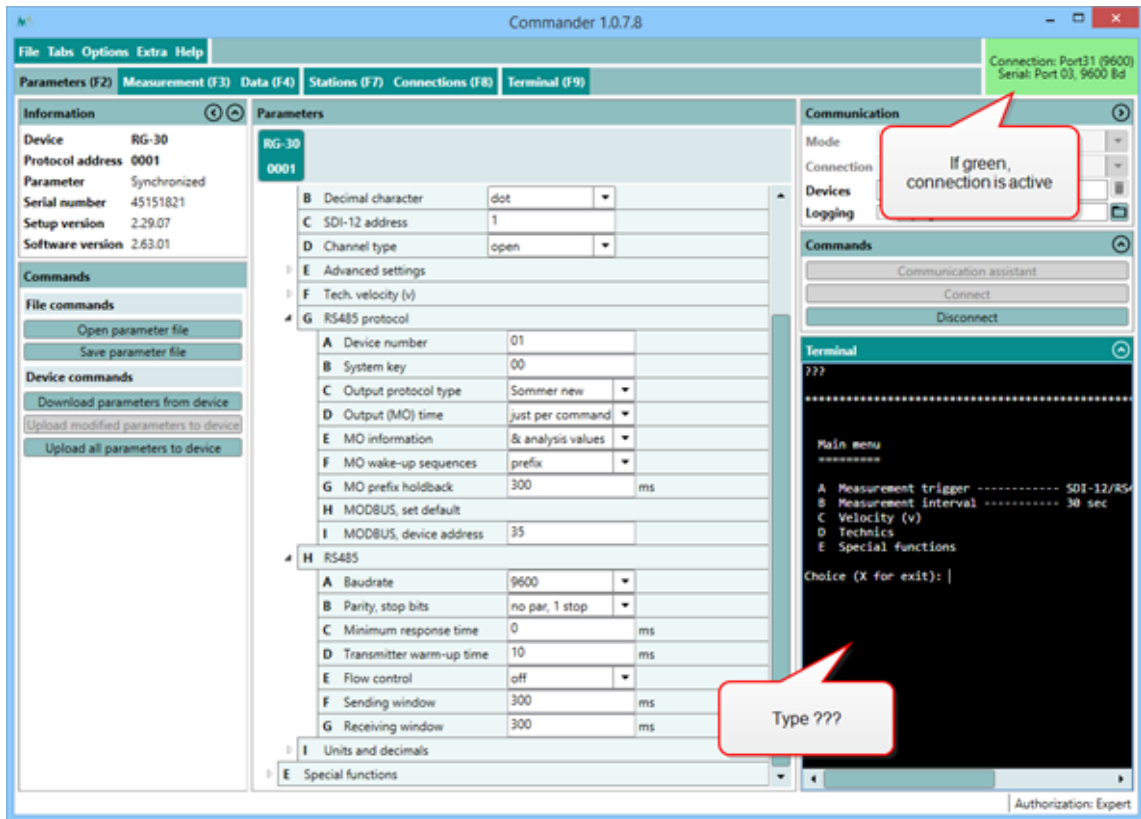

9. Navigate to *RS485 protocol* and select *MODBUS, set default...* Please note, that the index-letters might be different for your Sommer Messtechnik device!

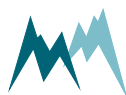

```

Terminal

Main menu
=====

A Measurement trigger ----- SDI-12/RS485
B Measurement interval ----- 30 sec
C Velocity (v)
D Technics
E Special functions

Choice (X for exit): d

Technics
=====

A Language/Sprache ----- english/englisch
B Decimal character ----- dot
C SDI-12 address ----- 1
D Channel type ----- open
E Advanced settings
F Tech. velocity (v)
G RS485 protocol
H RS485
I Units and decimals

Choice (X for exit): g

RS485 protocol
=====

A Device number
B System key --
C Output protocol
D Output (MO) t
E MO information
F MO wake-up se
G MO prefix holdback ----- 100 ms
H MODBUS, set default...
I MODBUS, device address ----- 35

Choice (X for exit): |

```

Enter the letter of 'MODBUS, set default ...'

10. Acknowledge the safety-note.

```

Start up testmode: 0x09

MODBUS, set default
=====

PLEASE NOTE: This process changes to 19200 baud, even parity, ...
DIRECTIVE: Please don't forget to change the serial counterpart too!

Are you sure?
(Press "RETURN" to assume)
(Press "Esc" to cancel)

```

Press Enter

11. After completion the following message will be displayed:

```

=> Testmode finished!
=> DIRECTIVE: Please don't forget to change the serial counterpart too!

```

12. Enter X until you get back to the main menu. The Sommer Messtechnik device is now restarted and available for Modbus-communication. As the connection-parameters have been changed to Modbus, the connection to the sensor is lost. Press Disconnect for completion.

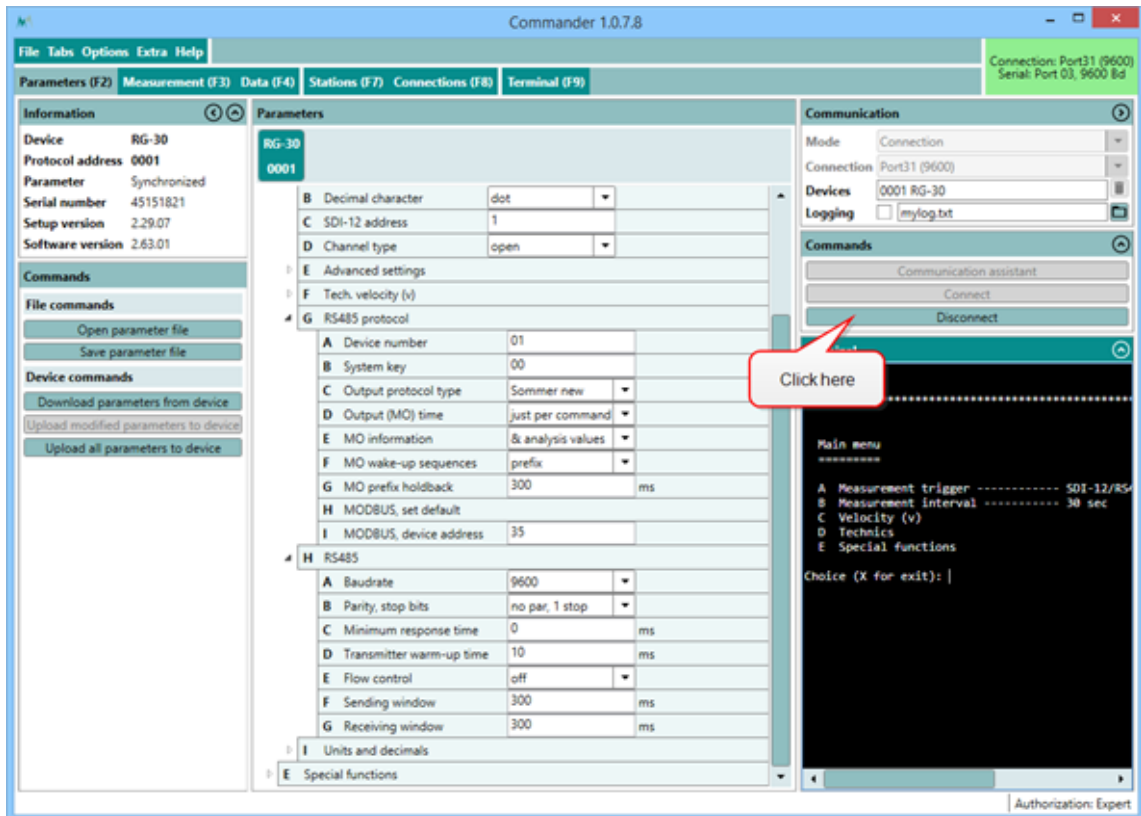

**NOTE**

By switching communication to Modbus with **MODBUS**, set default the following parameters are changed:

Parameter	Modbus setting
OP, measurement output	just per command
Output protocol (OP)	Modbus
MODBUS, device address	35
Sleep mode	Modbus, slow
Parity, stop bits	even par, 1 stop
Baud rate	19200
Flow control	off
Transmitter warm-up time	10 ms
Minimum response time	30 ms



**TIP** To change a parameter in the **Technics** menu you need to change your Commander-authorization to Expert. See [Change authorization](#) for instructions.

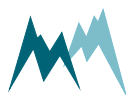

## 12.5.5 Modbus commands and registers

### 12.5.5.1 Read input registers

Input registers contain measurement values. The content of these registers is updated after each measurement.

	Register address	Variable	Unit / value	Bytes	Format
Test value	0	Hard coded test value	2.7519...	4	float
Main values	2	AUX		4	float
	4	Water level			
	6	Velocity <sup>1</sup>	<sup>2</sup>		
	8	Quality (SNR)	-		
	10	Discharge <sup>1</sup>			
	12	Area			
Special values	14	Learned velocity <sup>1</sup>		4	float
	16	Learned discharge <sup>1</sup>			
	18	Opposite direction content	%		
	20	Supply voltage	V		

<sup>1</sup>The positions of the measured and learned velocity and discharge can be switched with the setting [W-v priority](#).

<sup>2</sup>Unit according to submenu [Units and decimals](#).

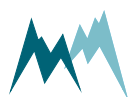

	Register address	Variable	Unit / value	Bytes	Format
Analysis values	22	Peak width	mm/s	4	float
	24	CSR	%		
	26	Area of the peak	-		
	28	RMS at the PIC	mV		
	30	Amplification	-		
	32	Amplification relation	%		
	34	Signal relation	%		
	36	Error code	-		
	38	not used	-		
	40	not used	-		
	42	not used	-		
Device info	65533	Device type and configuration	320X	2	unsigned int
	65534	Software version	XYZZ	2	unsigned int
	65535	Modbus implementation version	10100	2	unsigned int

Table 21 Input registers

### 12.5.5.2 Read and write holding registers

Holding registers are mainly used to configure the Modbus adapter communication. Configuration settings are read with function 03 (read holding registers) and written with function 06 (write single registers).



**NOTE** Restart the Modbus adapter after changing the configuration!

	Register address	Variable	Range	Bytes	Format
Config values	0	Modbus default <sup>1</sup>	0 - 1...read 1...write	2	unsigned int
	1	Modbus device address	1 to 247		
	2	RS-485 baud rate	0...1200 baud 1...2400 baud 2...4800 baud 3...9600 baud 4...19200 baud 5...38400 baud 6...57600 baud 7...115200 baud		
	3	RS-485 parity/ stop bits	0...no parity, 1 stop bit 1...no parity, 2 stop bits 2...even parity, 1 stop bit 3...odd parity, 1 stop bit		

Table 22 Holding registers

### 12.5.5.3 Report slave ID

The Modbus function 17 (report slave ID, read only) can be used to read basic information of the RQ-30+. The following example shows the response of function 17 of a RG-30 sensor, which is received in hex-format:



**EXAMPLE** 23 11 26 53 FF 27 74 20 53 6F 6D 6D 65 72 20  
20 52 47 2D 33 30 20 20 20 32 5F 37 31 72 30 31 20 34  
35 31 35 31 38 32 31 00 BB D4

<sup>1</sup>Writing "1" sets the Modbus default settings.

			Example	
	Content	Length (Bytes)	HEX-value	Decimal, ASCII
PDU* response	Slave address	1	23	35
	Function code	1	11	17
	Number of bytes (excl. slave-address, function code, NUL and CRC)	1	26	38
	Slave ID	1	53	"S"
	Run status (0=inactive; FF=active)	1	FF	255
	Modbus implementation version	2	27 74	10100
	Separator	1	20	" "
	Vendor string	7	53 6F 6D 6D 65 72 20	"Sommer "
	Separator	1	20	" "
	Device configuration	7	52 47 2D 33 30 20 20	"RG-30 "
	Separator	1	20	" "
	Software version	7	32 5F 37 31 72 30 31	2_71r01
	Separator	1	20	" "
	Serial number	8	34 35 31 35 31 38 32 31	45151821
	NUL	1	00	
CRC	2	BB D4		

\*Protocol Data Unit

Table 23 Slave ID

## 12.5.6 Reactivate Sommer Bus Protocol

Follow the instructions below to change the data output back to Sommer Bus Protocol:

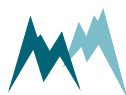

1. Open the **Connections (F8)** tab and click **New connection**.

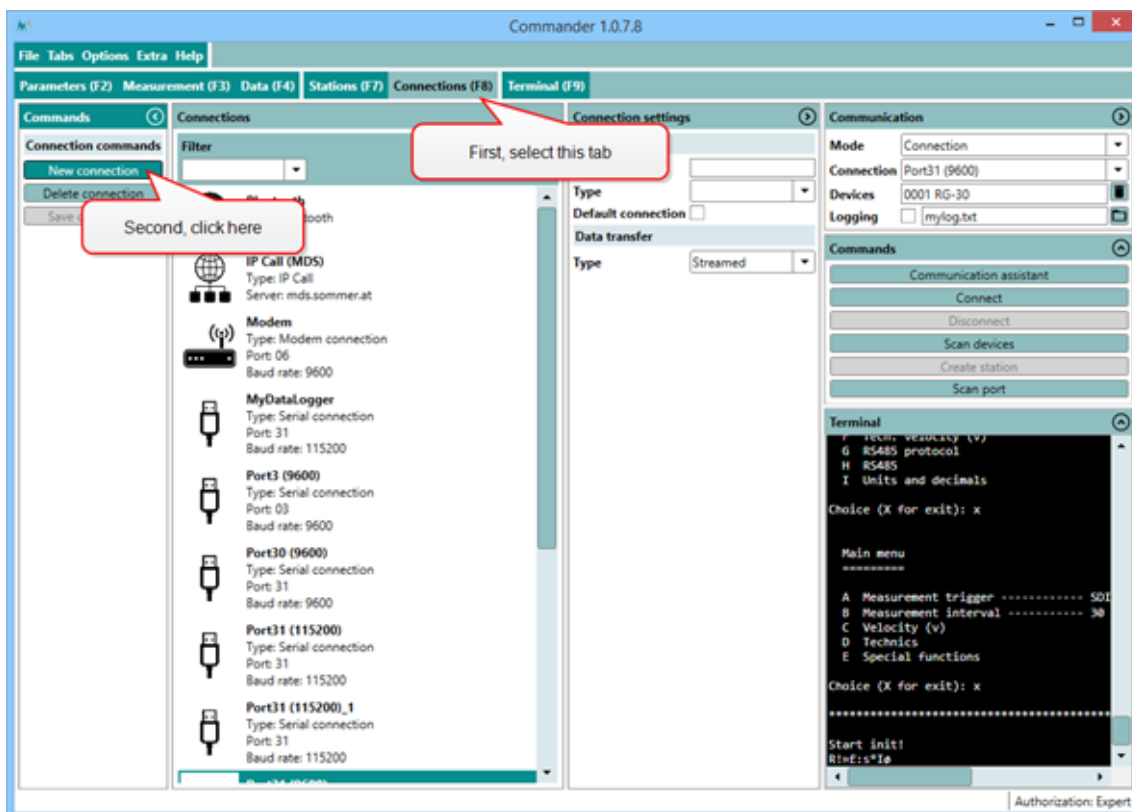

2. Enter the **Name** of the new connection. We recommend to use a meaningful name for later recognition, e.g. Modbus31 (19200) to indicate port 31 and Baud-rate 19200. Select the **Type** **Serial connection** and choose the **Port** your sensor is connected to, set the **Baud-rate** to **19200** and the **Parity/stop bits** to **Even par., 1 stop bit**.

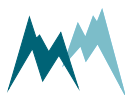

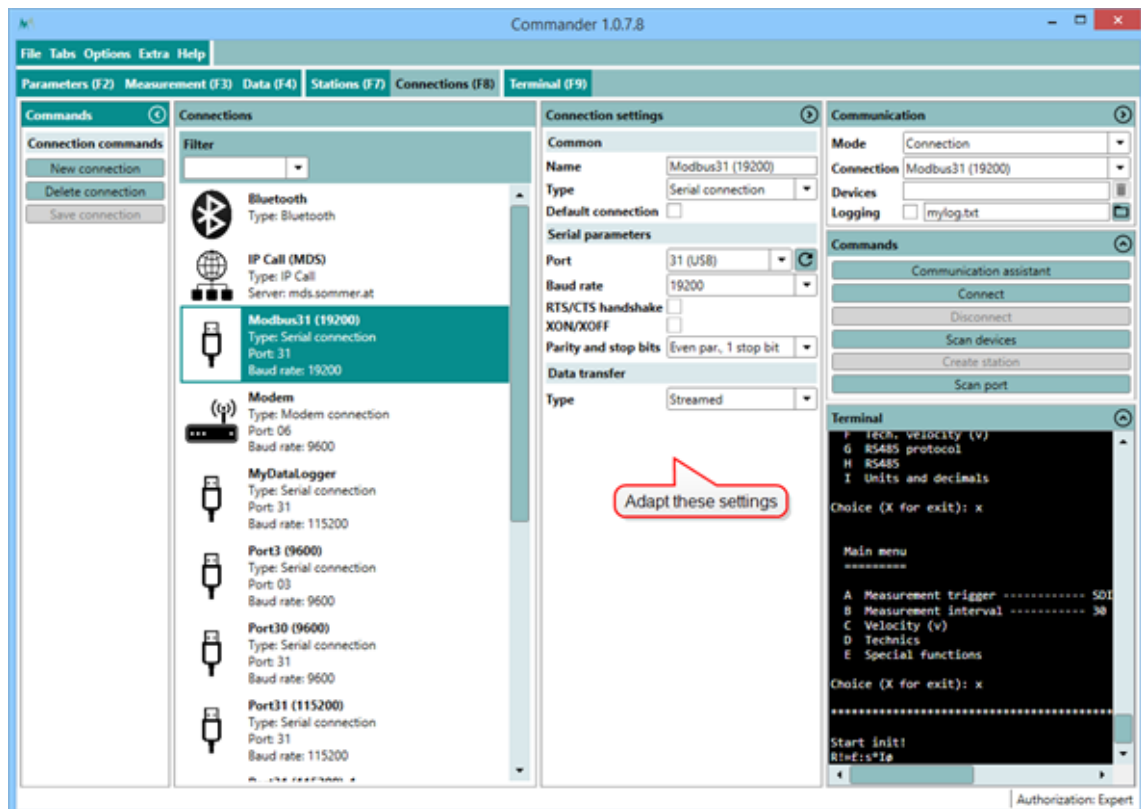

3. Click **Save connection**.
4. In the Communication window select **Mode Connection** and choose the **Connection** you have created. Then click **Connect**.

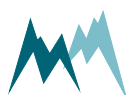

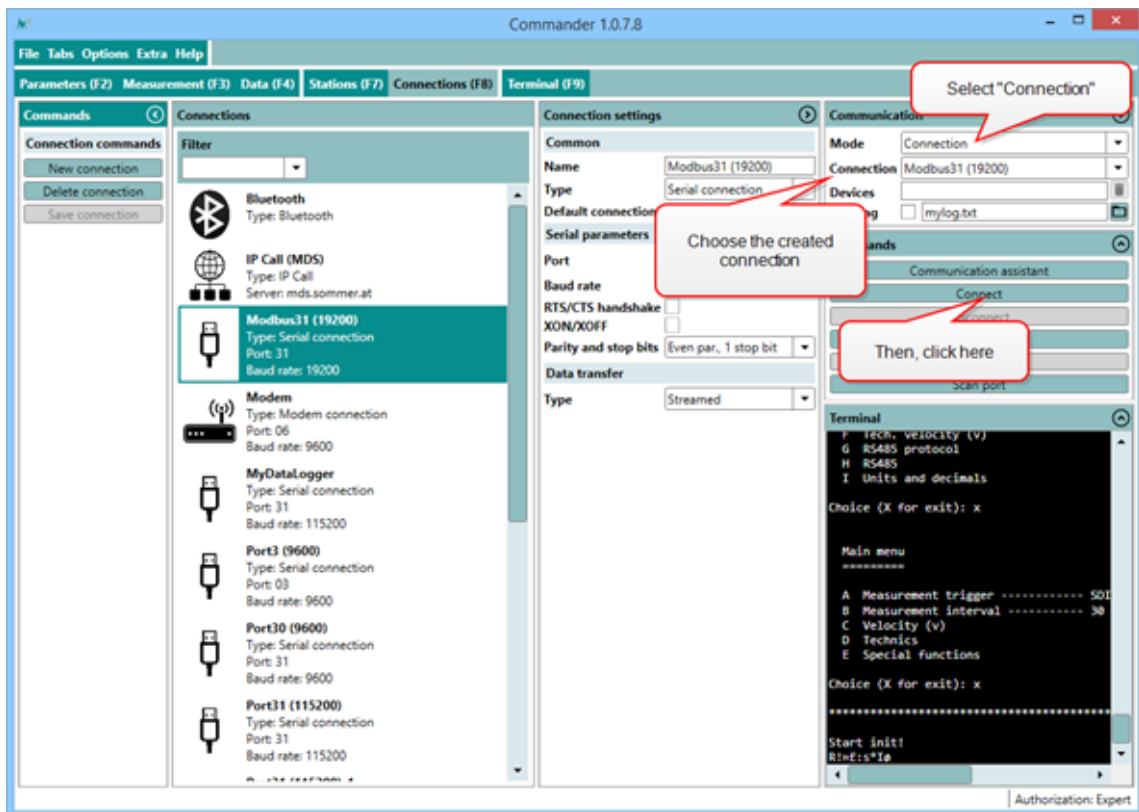

5. Download the parameters and save the parameter file as described in [Modbus configuration](#).



**TIP** Save the parameter file for future use and to document configuration changes!

6. Now, two options are available to revert communication back to the Sommer Bus Protocol:
  - A. If a parameter file is available that has the Sommer Bus Protocol enabled, the file can be loaded by clicking [Open parameter file](#), selecting the respective file and uploading the parameters to the device by clicking [Upload all parameters to device](#).

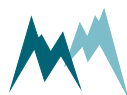

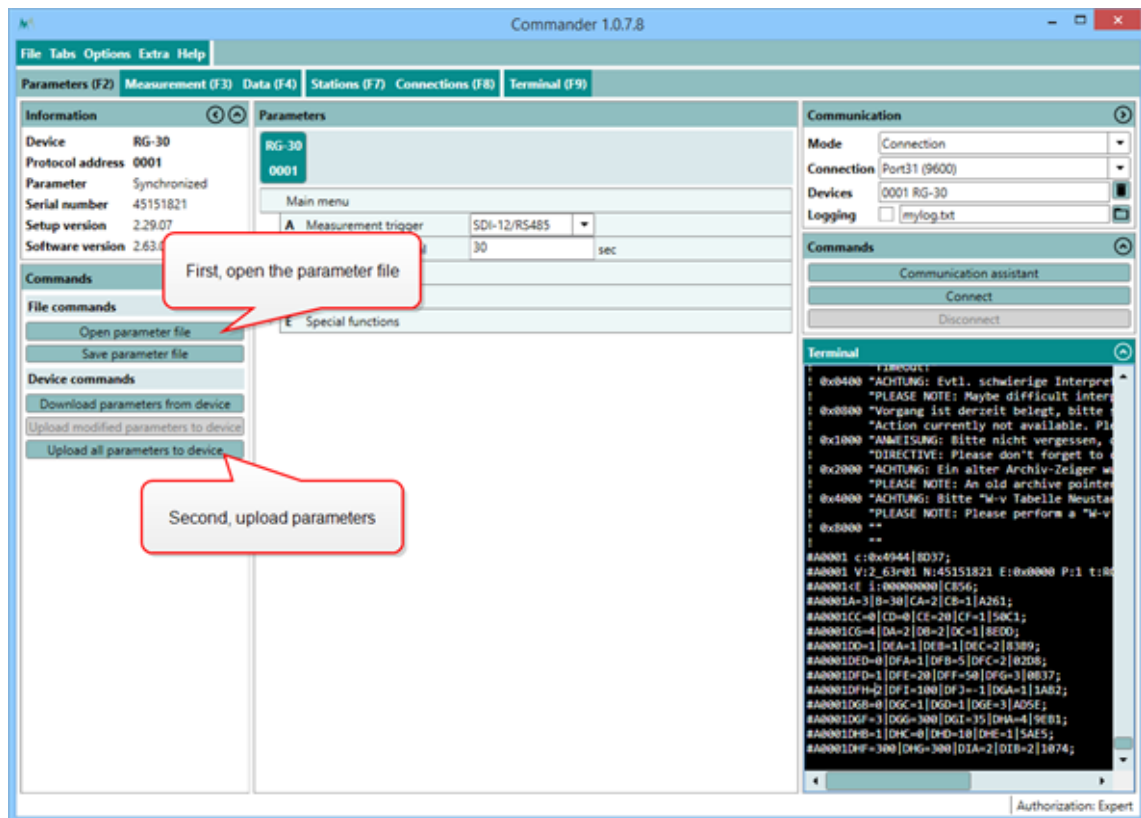

B. If no parameter file is available, the device has to be reset to its default configuration:

1. Click into the **Terminal** window and type ??? to enter the sensor-menu.

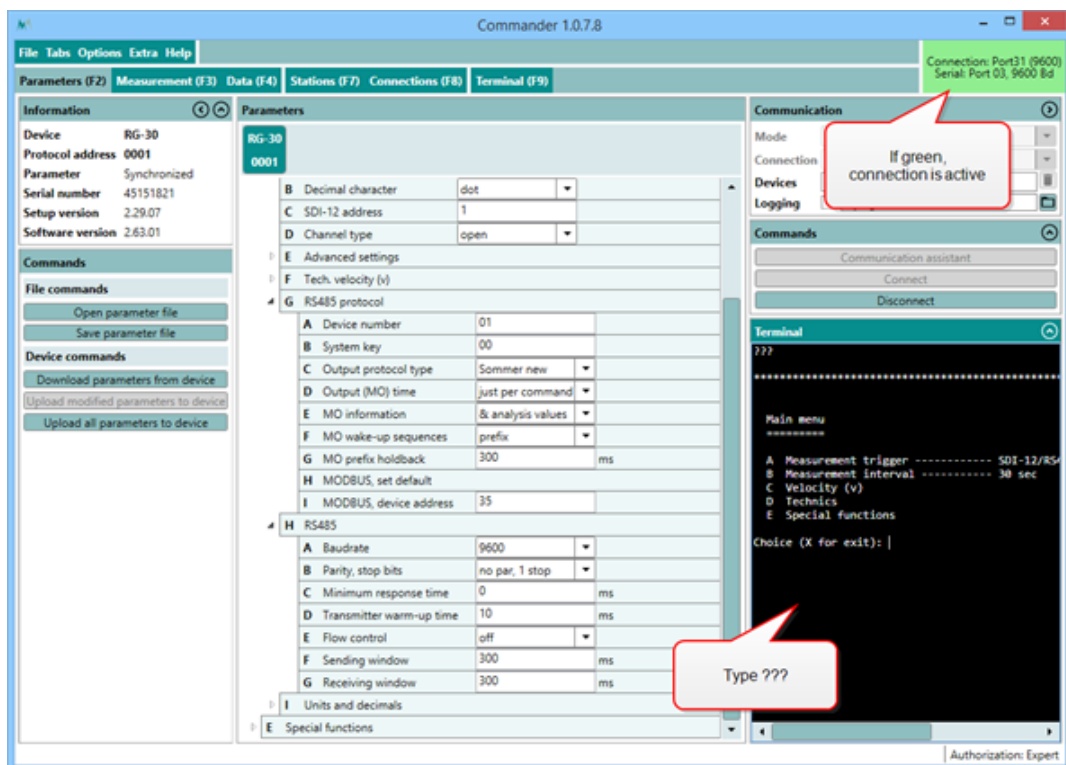

2. Navigate to **Special functions** and select **Set factory default...**
3. Acknowledge the safety-note.

```

Start up testmode: 0x07

Set factory default
AAAAAAAAAAAAAAAAAAAA

PLEASE NOTE: Please save all parameters before!
PLEASE NOTE: All user settings will be lost!
Are you sure?

(Press "RETURN" to assume)
(Press "Esc" to cancel)

=> Testmode finished!

```

4. Enter **X** until you get back to the main menu. The Sommer Messtechnik Sensor is now restarted and available in its initial configuration. As the connection-parameters have been changed to the default settings, the connection to the sensor is lost. Press **Disconnect** for completion.
7. Establish the original connection to the Sommer Messtechnik Sensor as described in **Modbus configuration**.
8. Download the sensor's parameters in the **Parameters (F2)** tab, adapt the required parameters, or upload your originally saved parameter file to the RQ-30+.

### 12.5.7 PLC integration

The RQ-30+ can be integrated into a PLC system as a slave device. It supports the PROFIBUS, PROFINET, EtherCAT and CANopen protocols. This requires an additional serial converter, e.g. Anybus Communicator.

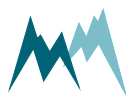

## 13 Analog output

### 13.1 What can I do with it?

Measurement values of water level, flow velocity, discharge and the auxiliary analog input can be returned by analog 4...20 mA signals. These can be configured in [4-20 mA outputs](#).

### 13.2 Activation

In the setting [Output status](#) the state of the analog output can be set to one of the following options:

ID	Option	Description
1	Off (default)	Analog outputs are inactive.
2	Just during TRIG	Analog outputs are only active, if an external signal is present at the TRIG input. The outputs are high as long as the signal at the TRIG input is high.
3	Always on	Analog outputs are permanently active.



**NOTE** The RQ-30+ delays analog data acquisition by 200 ms. If the output is set to *just during TRIG*, the analog output must be read with a delay of min. 200 ms after the trigger has been sent. This ensures that the analog measurement has sufficiently stabilized. As the analog measurement itself requires some time, the result should be read with a delay of *measurement duration + min. 1 second*.

### 13.3 Scaling

The variables and their analog output range are configured as described below.



**NOTE** The analog outputs may return currents between 0 and 21 mA. However, the accuracies stated in the specifications are only valid for signals within 4 to 20 mA!



If the measured value falls below or exceeds the 3.9...21 mA range, 3.9 mA and 21 mA, respectively, are returned. An exception are the measurement values 99999998 and 99999997, which return a 3.8-mA and 3.7-mA signal, respectively.



**ATTENTION** The 4-mA output should correspond to a measurement value at or below the expected minimum! With low current output the accuracy tends to decrease and cross-talk with other analog channels may occur.

### 13.3.1 IOU1 – AUX

The analog output IOU1 returns the measured auxiliary quantity, by default a temperature. The output corresponds to a linear equation defined by the span between 4 and 20 mA and an offset at 4 mA.



#### EXAMPLE

In the default configuration the parameter **IOU1, AUX 4 mA value** is set to **-20** and **IOU1, AUX 4-20 mA span** to **100**, as illustrated below.

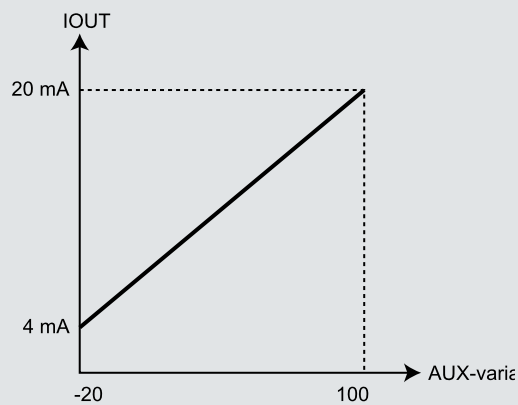

### 13.3.2 IOU2 – water level

The analog output IOU2 returns the water level. The output corresponds to a linear equation defined by the span between 4 and 20 mA and the offset at 4 mA.

By default, **IOU2, level 4-20 mA span** is set to the measurement range of the level sensor. However, the entire range is often not needed and would waste resolution.





### EXAMPLE

The Sommer Messtechnik SOMLEVEL-15 is a water level sensor with a measurement range from 0 to 15 m. In a monitoring setup the water level ranges only between 0 and 5m.

Setting **IOUT2, level 4-20 mA span** to 15m we would waste 2/3 of the analog output range (left graph). It is more appropriate to set **IOUT2, level 4-20 mA span** to 5m, taking advantage of the entire analog output range (right graph).

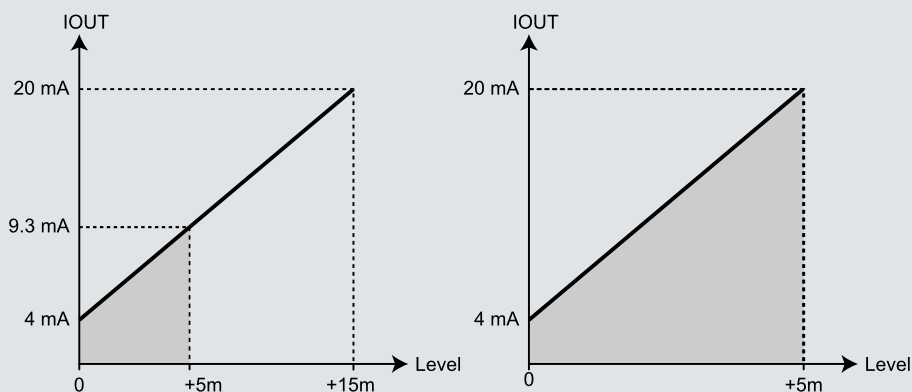

**NOTE** As water level is defined to be positive, do not use negative numbers for the level span! A negative span denotes the distance between the sensor and the water level and needs to be set carefully.

See the parameter description **IOUT2, level 4-20 mA span** for another example.

### 13.3.3 IOUT3 – flow velocity

The analog output IOUT3 returns the water flow velocity. Only the maximum velocity at 20 mA has to be set; a velocity of zero is assumed at 4 mA.

If only uni-directional water flow is allowed (this option is set in **Possible flow directions**), the 4 mA signal corresponds to a velocity of 0 m/s. If two-directional flow is selected, a 12 mA signal corresponds to a velocity of 0 m/s. In this case the maximum negative velocity corresponds to 4 mA and the maximum positive velocity to 20 mA. See **Figure 22** for an illustration of these two situations.

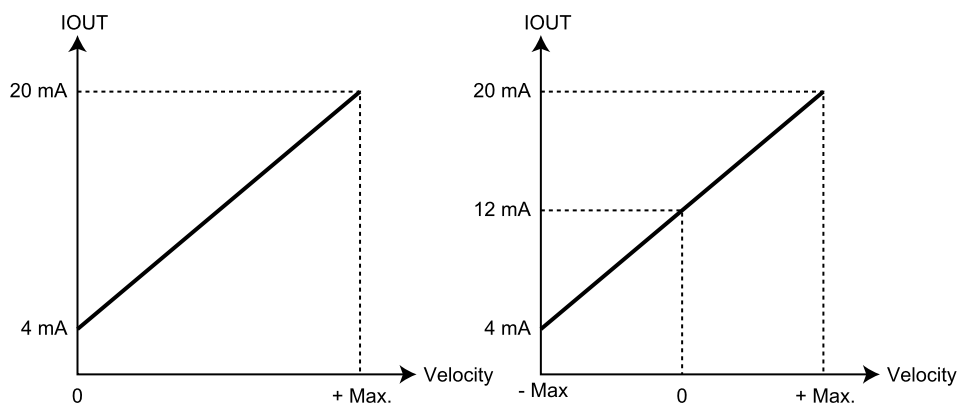

Figure 22 Definition of the 4 to 20 mA signal with uni- and two-directional water flow

### 13.3.4 IOUT4 – discharge

The analog output IOUT4 returns the water discharge. Only the maximum velocity at 20 mA has to be set; a discharge of zero is assumed at 4 mA.

If only uni-directional water flow is allowed (this option is set in [Possible flow directions](#)), the 4 mA signal corresponds to a discharge of zero. If two-directional flow is selected, a 12 mA signal corresponds to a discharge of zero. In this case the maximum negative discharge corresponds to 4 mA and the maximum positive discharge to 20 mA. See [Figure 22](#) for an illustration of these two situations.

## 13.4 Simulate current output

With this function the analog outputs can be simulated. A user-defined current value between 4 and 20 mA is applied to the analog output pins, which can be read by a connected data acquisition device or multimeter. By pressing Return/Enter again the simulation stops.

# 14 Parameter definitions

A	Measurement trigger .....	134
B	Measurement Interval .....	134
C	AUX .....	135
D	Level (W) .....	136
E	Velocity .....	139
F	Discharge table .....	143
G	DIG OUT .....	145
H	Technics .....	146
I	Region format .....	175
J	Special functions .....	175

## A Measurement trigger

`generic-measurement-trigger`

Measurements are initiated by one of the options listed in the table below.

The commands to trigger measurements via RS-485 and SDI-12 are described in [Communication](#).

Measured data are either returned directly after the measurement or can be requested by commands via the RS-485 or SDI-12 interface. The format of the returned data can be configured in the sub-menu [Protocol type](#).

ID	Option	Description
1	Interval (default)	Measurements are initiated in a specified interval.
2	TRIG input	Measurements are triggered by the positive edge of a DC-voltage signal applied to the TRIG input (low: 0 ... 0.6 V, high: 2.2 ... 28 V, pulse duration must be $\geq 500$ ms, delay between pulses must be $\geq 500$ ms)
3	SDI-12/RS-485	Measurements are externally triggered by commands via RS-485 or SDI-12 from ,e.g. a data logger.
4	all allowed	Measurement is triggered by all options mentioned above.

## B Measurement Interval

`generic-measurement-interval`

An internal measurement interval can be set for the RQ-30+. If selected in menu item [Measurement trigger](#), measurements are performed in the defined interval. However, a measurement is always completed before a new one is initiated.

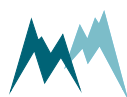

Value range	Default	Units
20...18'000	300	s

## C AUX

Specifies the auxiliary 0...2.5 V analog input. Usually, a temperature sensor is connected, but any analog sensor may be used. Additional configurations can be set in [Tech. AUX](#).

C-A	Mean value, no. of values .....	135
C-B	Test .....	136
C-C	Adjustment .....	136

### C-A Mean value, no. of values

`rq-discharge-mean-value-no`

Every water level measurement is stored internally in a buffer to compute a moving average. This setting defines the number of measurement values in the buffer. If the buffer is full the oldest value is replaced by the most recently recorded value.



**ATTENTION** If the measurement interval is long, the measurement data may lag behind! For example, if the measurement interval is 5 min and the filter is applied over 10 measurements, it may take up to 50 min until the full scale of a measurement shift is observed.

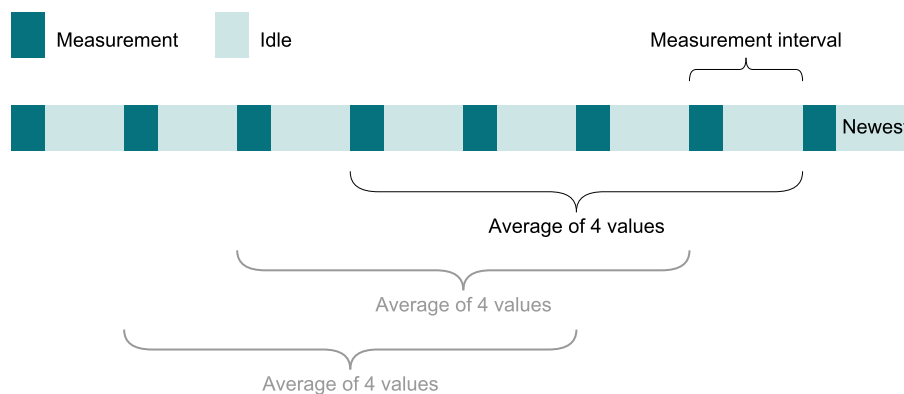

Value range	Default	Units
1...120	1	-



## C-B Test

rq-discharge-test-aux

A measurement of the auxiliary input is performed and after completion the result is displayed.

## C-C Adjustment

rq-discharge-adjustment

Function to adjust the measurement value. First, a measurement is performed and the result displayed. Afterwards, a target value is set and confirmed. The measurement is then adjusted to exactly match the target value. The adjustment of the water level measurement is described in detail in Section [Adjustment](#).

## D Level (W)

D-A	Mean value, no. of values .....	136
D-B	Test .....	137
D-C	Adjustment .....	137
D-D	W_Q, fixation level .....	137
D-E	WMA, maximum level .....	138
D-F	WLL, low level border .....	138
D-G	WCF, cease to flow level .....	138
D-H	W-v table reset .....	139

### D-A Mean value, no. of values

rq-discharge-mean-value-no

Every water level measurement is stored internally in a buffer to compute a moving average. This setting defines the number of measurement values in the buffer. If the buffer is full the oldest value is replaced by the most recently recorded value.



**ATTENTION** If the measurement interval is long, the measurement data may lag behind! For example, if the measurement interval is 5 min and the filter is applied over 10 measurements, it may take up to 50 min until the full scale of a measurement shift is observed.

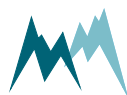

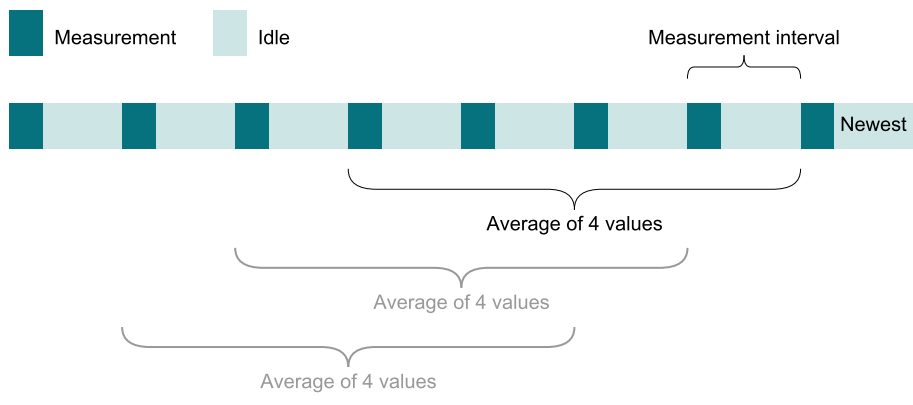

Value range	Default	Units
1...120	1	-

### D-B Test

`rq-discharge-test-level`

A level measurement is performed and after completion the result is displayed.

### D-C Adjustment

`rq-discharge-adjustment`

Function to adjust the measurement value. First, a measurement is performed and the result displayed. Afterwards, a target value is set and confirmed. The measurement is then adjusted to exactly match the target value. The adjustment of the water level measurement is described in detail in Section [Adjustment](#).

### D-D W\_Q, fixation level

`rq-discharge-fixation-level`

The fixation level W\_Q ist the vertical distance between the deepest point in the cross-sectional profile and the bottom surface of the RQ-30+.



**ATTENTION** Use the [Adjustment](#) button to set the fixation level W\_Q automatically!

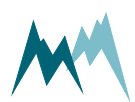

Value range	Default	Units
-9999.99...99999.99	15/30	Unit of level

## D-E WMA, maximum level

`rq-discharge-maximum-level`

The maximum possible water level. This value should be smaller as or equal to the fixation level  $W_Q$ .



**NOTE** If set to 0 the machine learning function is deactivated.

Value range	Default	Units
-9999.99...99999.99	0	Unit of level

## D-F WLL, low level border

`rq-discharge-low-level-border`

The low level border is the water level below which velocity measurements are not feasible. However, the RQ-30+ calculates the velocity below WLL with its learning function.

The low level border constitutes the lower limit of the water level range for the calculation of the learning function (continuously updated relation between water level and flow velocity).

Value range	Default	Units
-9999.99...99999.99	0	Unit of level

## D-G WCF, cease to flow level

`rq-discharge-cease-to-flow-level`

The cease to flow level is the water level at which there is no water flow in the channel. This may or may not be the river bed.

For water levels between the cease to flow level and the low level border velocities and discharges are extrapolated from the  $W-v$  relation. At water levels below WCF no velocities are returned.

Value range	Default	Units
-9999.99...99999.99	0	Unit of level

## D-H W-v table reset

`rq-discharge-w-v-table-reset`

The stored W-v table is deleted and the W-v learning starts anew. This is especially required if the water flow regime and thus the W-v relation have changed, e.g. new channel profile.

## E Velocity

E-A	Viewing direction .....	139
E-B	Possible flow directions .....	140
E-C	River inclination .....	140
E-D	Yaw angle .....	141
E-E	Measurement duration .....	141
E-F	Filter, no. of values .....	141
E-G	Filter, type .....	142

### E-A Viewing direction

`rq-discharge-viewing-direction`

This setting defines the viewing direction of the RQ-30+ sensor in relation to the flow direction of the river.

ID	Option	Description
1	downstream	The RQ-30+ sensor is directed in flow direction.
2	upstream (default)	The RQ-30+ sensor is directed against the flow direction.

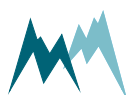

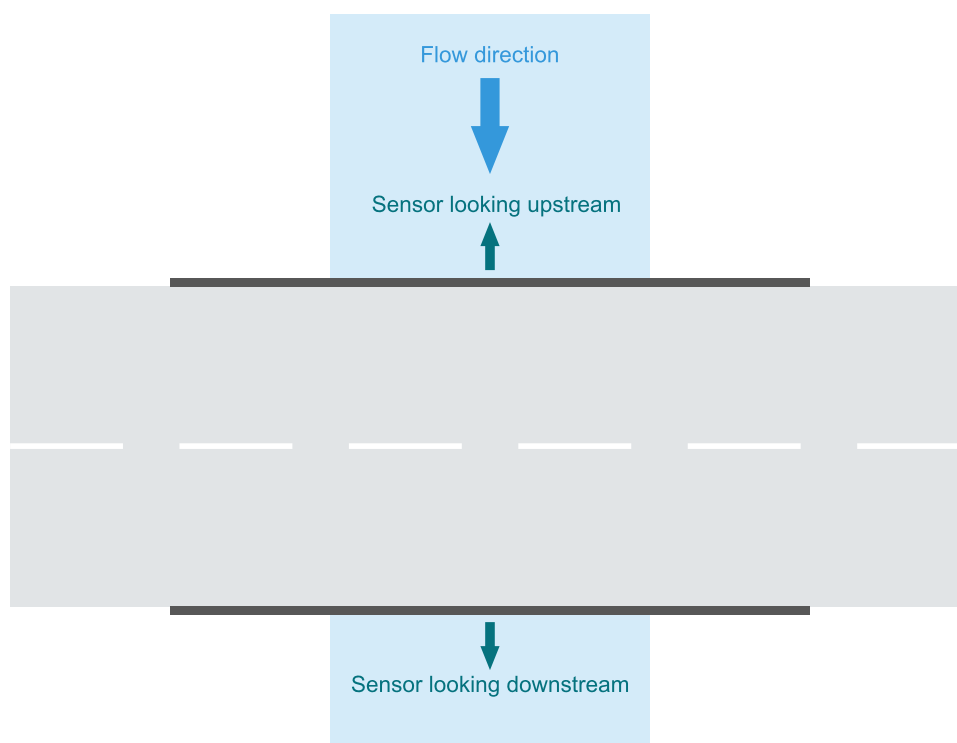

## E-B Possible flow directions

`rq-discharge-possible-flow-directions`

Due to the direction separation (see [Flow direction separation](#)) the RQ-30+ sensor can identify the flow direction. Therefore it has to be defined if the river only flows in one direction or if bi-directional flow can occur as for example under tidal influence.

ID	Option	Description
1	just downstream (default)	Only downstream flow is recorded.
2	two (tide)	Down- and upstream flow is recorded. Upstream flow is indicated by a negative sign.

## E-C River inclination

`rq-discharge-river-inclination`

The RQ-30+ sensor only measures its own vertical inclination. To compensate for the influence of a sloping river surface an additional correction can be set. It is either added or subtracted depending on the flow direction. Generally, rivers do not show an appreciable inclination of the water surface. For the possible flow direction *two (tide)* an inclination of *0* has to be set.

Value range	Default	Units
0...90	0	Degree

## E-D Yaw angle

`rq-discharge-yaw-angle`

Usually the main water flow is perpendicular to the cross Section of a river and the RQ-30+ sensor is mounted in the same way. However, if the RQ-30+ sensor has to be rotated horizontally, the rotation angle can be considered for by adjusting this setting. To ensure a reliable and accurate velocity measurement it is recommended to select a yaw angle smaller than 30°.

Value range	Default	Units
0...60	0	Degree

## E-E Measurement duration

`rq-discharge-measurement-duration`

The measurement duration defines the duration of a single measurement. During this time the RQ-30+ signal is recorded and the velocity radar spectrum is analyzed.

Generally, a measurement duration of 30 ... 60 s is recommended. It should be at least 10 s. A long measurement time increases power consumption.

Please see [Warm-up time](#) for an illustration of the measurement duration in relation to the [Measurement Interval](#) and the level measurement.

Value range	Default	Units
5...240	30	Seconds

## E-F Filter, no. of values

`rq-discharge-filter-values`

Every velocity measurement is stored internally in a buffer for filtering. This setting defines the number of measurement values in the buffer. If the buffer is full the oldest value is replaced by the most recently recorded value.

The number of buffered values depends on the turbulence of the water surface. Highly turbulent rivers demand a small buffer, rivers or irrigation channels with low turbulence require a larger buffer.





**ATTENTION** If the measurement interval is long, the measurement data may lag behind! For example, if the measurement interval is 5 min and the filter is applied over 10 measurements, it may take up to 50 min until the full scale of a measurement shift is observed.

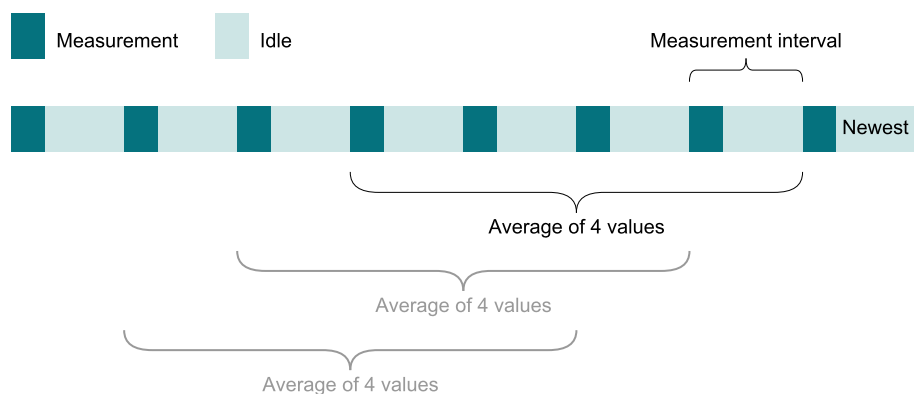

Value range	Default	Units
1...120	1	-

## E-G Filter, type

`rq-discharge-filter-type-velocity`

The velocity values in the buffer can be filtered by one of the following options:

ID	Option	Description
1	moving average (default)	The mean value of all buffered values is calculated.
2	eliminate spikes	To eliminate spikes the mean value is calculated without the 5 highest and 5 lowest buffered values. If the buffer size is smaller than 15 two third of the values are eliminated.
3	minimum value	The smallest value from the buffer is returned.
4	median value	The median value of the buffered data is returned.

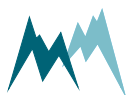

## F Discharge table

rq-discharge-table

As described in Section [Determination of water discharge](#) the discharge is calculated from the measured water level and the measured velocity considering the cross-Sectional area and the k-factors. The values of the cross-Sectional areas and the k-factors are set in the discharge table.

The information is arranged in 16 lines ordered from low to high water levels. The values for water levels between two lines are interpolated linearly.

The discharge table can be generated with the software Q-Commander of Sommer GmbH. This program calculates areas and k-factors from a cross-Sectional profile and additional characteristics of the water channel. It also provides functionality to transfer the discharge table to the memory of the RQ-30+ sensor.

	Status	Level (W)	K value	Area (A)
		[m]	[ ]	[m <sup>2</sup> ]
01	on	0.4	64.0	4.7
02	on	0.6	68.7	9.5
03	on	0.8	72.1	14.4
04 ... 14	...	...	...	...
15	on	4.9	79.5	141.8
16	on	6.7	80.7	202.4

### F-A Status

rq-discharge-status-discharge-table

The status describes the activity and priority of a data line within the discharge table. The following options are available:

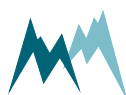

ID	Option	Description
1	Off (default)	The line is inactive.
2	theor.	The line is active with theoretical values from a numerical hydraulic model.
3	calib.	The line is active with calibrated values from a reference measurement. These values have high priority.

## F-B Level (W)

`rq-discharge-level`

The entries of the discharge table are ordered from low to high water levels. The unit of the water level is defined in the submenu [Units and decimals](#).

Value range	Default	Units
-9999.99...99999.99	0	Unit of level

## F-C k value

`rq-discharge-k-value`

The k-factor is the ratio between the mean and the measured local velocities at the defined water level (see [k-Factors](#)). The value is scaled to 1, i.e. a k-factor of 70 % is entered as 0.700.

Value range	Default	Units
0...99999.999	1	-

## F-D Area (A)

`rq-discharge-area`

The area is the cross-Sectional area of the water filled part of the river or flow channel.

Value range	Default	Units
-9999.99...999999.99	0	Unit of area

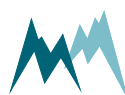

## G DIG OUT

G-A	LM, trigger via .....	145
G-B	LM, limit type .....	145
G-C	LM, limit value .....	145
G-D	LM, hysteresis .....	146

### G-A LM, trigger via

`rq-discharge-lm-trigger-via`

This parameter defines the method by which the discharge is monitored. One of the following options can be selected:

ID	Option	Description
1	Off (default)	Surveillance deactivated
2	discharge	Surveillance of the discharge of the device
3	multi-point discharge	Same as option discharge
4	level	Surveillance of the level
5	velocity	Surveillance of the velocity
6	AUX	Surveillance of the AUX input

### G-B LM, limit type

`rq-discharge-lm-limit-type`

This parameter defines the orientation of the threshold. The following options are available:

ID	Option	Description
1	limit overrun (default)	Violation when the defined value exceeds the limit
2	limit underrun	Violation when the defined value drops below the limit

### G-C LM, limit value

`rq-discharge-lm-limit-value`

This parameter specifies the magnitude of the limit value.

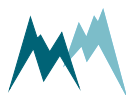

Value range	Default	Units
-99999.99...999999.99	100	Unit of selected parameter (level, velocity,...)

## G-D LM, hysteresis

rq-discharge-lm-hysteresis

The specification of a hysteresis value suppresses multiple violations if the measurement value closely fluctuates around the threshold. After a violation the hysteresis value has to be exceeded to cause a new violation. The hysteresis is an absolute value and is added with the correct sign to the threshold. Figure 23 illustrates an example.

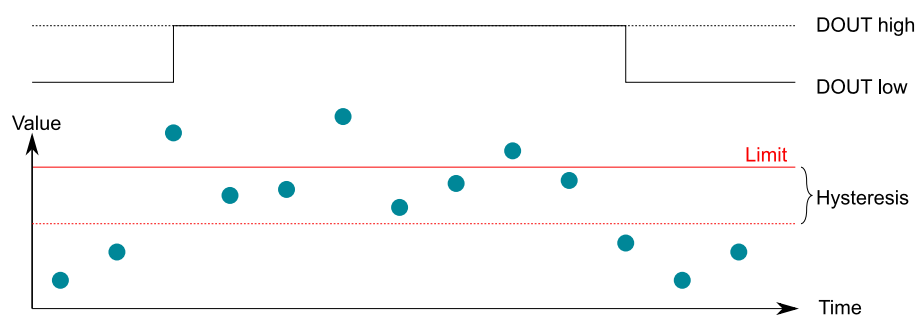
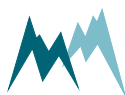

Figure 23 Hysteresis in monitoring of water level W

Value range	Default	Units
0...999999.99	2	Unit of selected parameter (level, velocity,...)

## H Technics

H-A	SDI-12 address .....	147
H-B	Channel type .....	147
H-C	W-v priority .....	147
H-D	Area correction .....	148
H-E	Units and decimals .....	148
H-F	SBP device addressing .....	155
H-G	RS-485 (COM) .....	155
H-H	Advanced settings .....	161
H-I	Tech. AUX .....	163
H-J	Tech. level (W) .....	164
H-K	Tech. velocity (v) .....	165
H-L	4-20 mA outputs .....	172



## H-A SDI-12 address

generic-sdi-12-address

The address is a unique identifier of the sensor within a SDI-12 bus system.

Value range	Default	Units
0...9, a...z, A...Z	0	-

## H-B Channel type

rq-discharge-channel-type

This parameter specifies the type of flow channel where the RQ-30+ sensor is installed. The selection determines how the flow velocity is calculated from the velocity spectrum (see [Channel type](#) for details). One of the following options can be selected:

ID	Option	Description
1	open (default)	Open flow channel.
2	covered	Closed or covered flow channel, e.g. discharge pipe.

## H-C W-v priority

rq-discharge-w-v-priority

The W-v priority determines if the measured or learned values of the velocity and discharge are returned (see [W-v priority](#)).



**ATTENTION** For water levels below the low level border WLL the learned velocity and discharge are returned.

ID	Option	Description
1	no (default)	The measured velocity and discharge are returned as part of the main values. The learned velocity and discharge are returned as part of the special values.
2	yes	The learned velocity and discharge are returned as part of the main values. The measured velocity and discharge are returned as part of the special values.

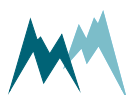

## H-D Area correction

`rq-discharge-area-correction`

In case of small changes of the river bed, and consequently the cross-sectional area, the discharge table can be adjusted by an offset. It is recommended to avoid larger corrections with this parameter.

Value range	Default	Units
-99999.99...999999.99	0	Unit of area

## H-E Units and decimals

H-E-A	AUX unit .....	148
H-E-B	AUX decimals .....	148
H-E-C	Level, unit .....	149
H-E-D	Level, decimals .....	149
H-E-E	Velocity, unit .....	149
H-E-F	Velocity decimals .....	150
H-E-G	Discharge (Q), unit .....	150
H-E-H	Discharge (Q) decimals .....	151
H-E-I	Total discharge volume unit* .....	151
H-E-J	Total discharge volume decimal .....	151
H-E-K	Simulation, discharge volume .....	152
H-E-L	Area (A), unit .....	154
H-E-M	Area (A) decimals .....	154

### H-E-A AUX unit

`generic-units-aux`

The unit of the quantity measured on the auxiliary input. Default is °C.

### H-E-B AUX decimals

`generic-decimals-aux`

The number of decimal places of the quantity measured on the auxiliary input.

Value range	Default	Units
0...6	0	-

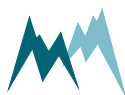

**H-E-C Level, unit**`generic-units-level`

The following units of the level/distance can be selected:

ID	Option	Description
1	mm (default)	Millimeter
2	cm	Centimeter
3	m	Meter
4	in	Inch
5	ft	Feet
6	yd	Yard

**H-E-D Level, decimals**`generic-decimals-level`

The number of decimal places for the measured level/distance.

Value range	Default	Units
0...6	0	-

**H-E-E Velocity, unit**`generic-units-velocity`

The following units of the flow velocity can be selected:

ID	Option	Description
1	mm/s	Millimeter per second
2	m/s (default)	Meter per second
3	km/h	Kilometer per hour

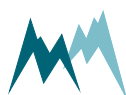

ID	Option	Description
4	ft/s	Feet per second
5	in/s	Inch per second
6	mph	Miles per hour
7	kn	Knots

### H-E-F Velocity decimals

generic-decimals-velocity

The number of decimal places for the measured velocity.

Value range	Default	Units
0...6	2	-

### H-E-G Discharge (Q), unit

generic-units-discharge

The following units of the water discharge can be selected:

ID	Option	Description
1	l/s	Liter per second
2	m <sup>3</sup> /s (default)	Cubic meter per second
3	ft <sup>3</sup> /s	Cubic feet per second
4	ac-ft/h	Acre-feet per hour
5	us. gal/s	US gallons per second
6	en. gal/s	English gallons per second
7	MI/d	Megaliter per day
8	m <sup>3</sup> /h	Cubic meter per hour

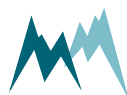



**ATTENTION** When the discharge unit is changed the internal discharge volume counter is reset to 0!

## H-E-H Discharge (Q) decimals

generic-decimals-discharge

This parameter sets the number of decimal places for the water discharge.

Value range	Default	Units
0...6	0	-

## H-E-I Total discharge volume unit\*

generic-units-total-discharge

The following units of the total water discharge can be selected:

ID	Option	Description
1	l	Liter
2	m <sup>3</sup> (default)	Cubic meter
3	ft	Cubic feet
4	ac-ft	Acre-feet
5	us. gal	US gallons
6	en. gal	English gallons
7	MI	Megaliter

## H-E-J Total discharge volume decimal

generic-decimals-total-discharge

This parameter sets the number of decimal places for the total water discharge.

Value range	Default	Units
0...6	0	-

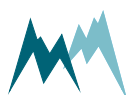

## H-E-K Simulation, discharge volume

rq-discharge-simulation-SQ

With this function a user defined discharge volume can be simulated. This simulation is based on the settings in menus [Measurement trigger](#) and [Units and decimals](#).



### EXAMPLE

The following RQ-30+ settings are assumed:

Discharge (Q), unit l/s

Discharge (Q) decimals 1

Total discharge volume unit\* m<sup>3</sup>

Total discharge volume decimal 1

After pressing the button in Q-Commander a window will pop up:

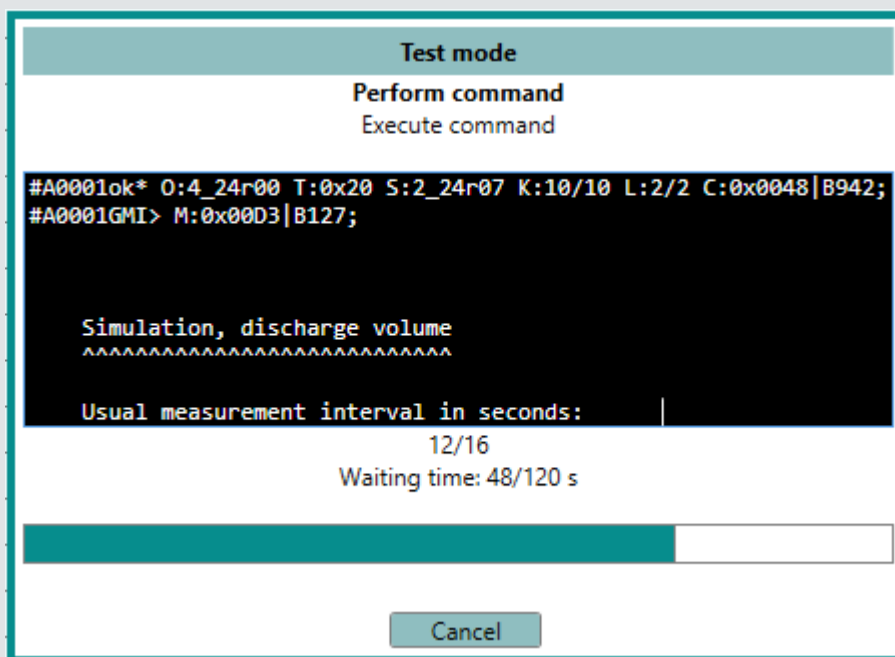

This dialog will only be displayed if the measurement trigger is set to *SDI 12/RS485*! If the measurement trigger is set to *interval* the defined measurement interval will be adopted.

Enter the interval by which measurements are triggered externally (usually a data logger) and confirm with **Enter**. Maximum and minimum discharge rates are calculated:



```

Test mode
Perform command
Execute command

#A0001ok* O:4_24r00 T:0x20 S:2_24r07 K:10/10 L:2/2 C:0x0048|B942;
#A0001GMI> M:0x0003|B127;

Simulation, discharge volume
AAAAAAAAAAAAAAAAAAAAAAAAAAAA

Usual measurement interval in seconds:      60

Maximum discharge:                          11574.1 l/s
Minimum discharge (suggestion):             0.2 l/s

PLEASE NOTE: DIG-OUT setting determines maximum discharge!
PLEASE NOTE: If limits are not ok, please view manual to adjust settings properly!

Desired simulation discharge in l/s:         |
                                           12/16
                                           Waiting time: 13/120 s

```

Notice: Simulated minimum and maximum discharges are dependent on the settings in Units and decimals. Furthermore, the RQ-30+ sensor provides 8 characters to display the total daily discharge. Thus, in the current example a maximum daily discharge of *999'999.9 m3* can be displayed before data overflow occurs. This corresponds to a maximum discharge rate of 11'574.1 l/s.

Enter the discharge rate you want to simulate, e.g. *1'000 l/s*, and press **Enter**. The result lists the simulated discharge volume per measurement and a forecasted, daily discharge volume:



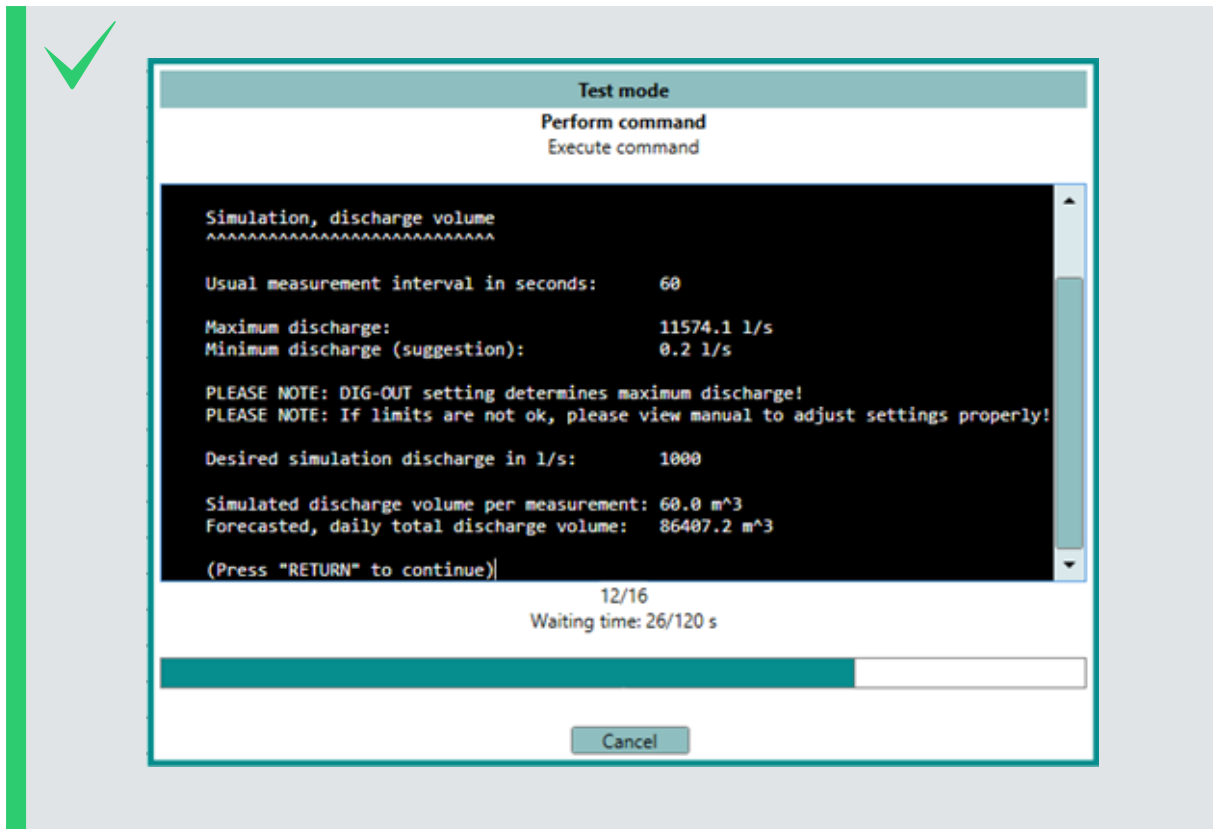

## H-E-L Area (A), unit

generic-units-area

The following units of the cross-sectional area can be selected:

ID	Option	Description
1	dm <sup>2</sup>	Square decimeter
2	m <sup>2</sup> (default)	Square meter
3	ft <sup>2</sup>	Square feet
4	yd <sup>2</sup>	Square yard

## H-E-M Area (A) decimals

generic-decimals-area

This parameter sets the number of decimal places for the cross-sectional area.

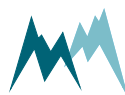

Value range	Default	Units
0...6	2	-

## H-F SBP device addressing

H-F-A	Device number .....	155
H-F-B	System key .....	155

### H-F-A Device number

`generic-rs-485-protocol-device-number`

The device number is used for the unique identification of the device in a bus system.

Value range	Default	Units
0...98	1 (default)	-

### H-F-B System key

`generic-rs-485-protocol-system-key`

The system key defines the bus system of the device. Thus, different conceptual bus systems can be separated. Interfering bus systems occur if the remote radio coverage of two measurement systems overlap. In general, the system key should be set to 00.

Value range	Default	Units
0...99	0	-

## H-G RS-485 (COM)

H-G-A	Output protocol .....	156
	H-G-A-A Protocol type .....	156
	H-G-A-B Measurement output .....	156
	H-G-A-C Information .....	157
	H-G-A-D Wake-up sequence .....	157
	H-G-A-E Prefix holdback .....	158
	H-G-A-F MODBUS, set default .....	158
	H-G-A-G MODBUS, device address .....	158
H-G-B	Port .....	158
	H-G-B-A Baud rate .....	159

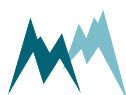

H-G-B-B	Parity, stop bits .....	159
H-G-B-C	Minimum response time .....	159
H-G-B-D	Transmitter warm-up time .....	160
H-G-B-E	Flow control .....	160
H-G-B-F	Sending window .....	160
H-G-B-G	Receiving window .....	160

## H-G-A Output protocol

H-G-A-A	Protocol type .....	156
H-G-A-B	Measurement output .....	156
H-G-A-C	Information .....	157
H-G-A-D	Wake-up sequence .....	157
H-G-A-E	Prefix holdback .....	158
H-G-A-F	MODBUS, set default .....	158
H-G-A-G	MODBUS, device address .....	158

### H-G-A-A Protocol type

`generic-rs-485-protocol-type`

The type of the serial output protocol. The following options are available:

ID	Option	Description
1	Sommer new (SBP)	Sommer Bus Protocol (SBP); data values are returned with an index starting at 1. Multiple strings may be returned.
2	Standard	Standard protocol; data values are returned without an index in one string.
6	MODBUS	Modbus protocol
7	Sommer old (SBP) (default)	Sommer Bus Protocol (SBP); data values are returned with an index starting at 0. Multiple strings may be returned.



**NOTE** For MODBUS applications run `MODBUS, set default` to get the appropriate communication settings.

### H-G-A-B Measurement output

`generic-rs-485-protocol-measurement-output`

Specifies the timing of the serial data output.

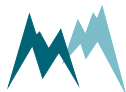

ID	Option	Description
1	Just per command	The output is only requested by commands via RS-485.
2	After measurement (default)	The serial data output is performed automatically right after each measurement.
3	Pos. TRIG slope	The output is triggered by a positive edge of a control signal applied to the trigger input.

### H-G-A-C Information

`generic-rs-485-protocol-information`

The main measurement values are always included in the data output string. Additionally, special and analysis values can be included.

ID	Option	Description
1	Main values	Only the main values are returned.
2	& Special values (default)	Main values and special values are returned.
3	& Analysis values	Main, special and analysis values are returned.

### H-G-A-D Wake-up sequence

`generic-rs-485-protocol-wake-up-sequence`

Serial data can be transmitted to a recording device automatically without a request. However, many devices demand a wake-up sequence before they can receive and process data. The RQ-30+ has the option to send a sync sequence and a prefix before data are transmitted (see [Waking-up a connected data logger](#)). The following options are available:

ID	Option	Description
1	Off	No wake-up sequence
2	Sync	The sync sequence UU~?~? is sent before the output string.
3	Prefix (default)	A blank with a time delay is sent before the output string.
4	Prefix & Sync	A blank with a time delay and the sync sequence UU~?~? is sent before the output string.



**H-G-A-E Prefix holdback**`generic-rs-485-protocol-prefix-holdback`

The hold-back time defines the time delay between the prefix and the data string.

Value range	Default	Units
0...5'000	300	ms

**H-G-A-F MODBUS, set default**`generic-rs-485-protocol-modbus-set-default`

Sets all parameters required for Modbus communication automatically. The following settings are adapted:

Parameter	Modbus setting
OP, measurement output	just per command
Output protocol (OP)	Modbus
MODBUS, device address	35
Sleep mode	Modbus, slow
Parity, stop bits	even par, 1 stop
Baud rate	19200
Flow control	off
Transmitter warm-up time	10 ms
Minimum response time	30 ms

**H-G-A-G MODBUS, device address**`generic-rs-485-protocol-modbus-device-address`

Unique device address for the Modbus protocol.

Value range	Default	Units
1...247	35	-

**H-G-B Port**

H-G-B-A	Baud rate .....	159
H-G-B-B	Parity, stop bits .....	159
H-G-B-C	Minimum response time .....	159
H-G-B-D	Transmitter warm-up time .....	160
H-G-B-E	Flow control .....	160
H-G-B-F	Sending window .....	160
H-G-B-G	Receiving window .....	160

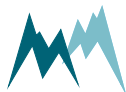

**H-G-B-A Baud rate**`generic-rs-485-port-baud-rate`

The following transmission rates in bps (baud) can be selected:

ID	Option	Description
1	1'200	-
2	2'400	-
3	4'800	-
4	9'600 (default for sensors and data logger inputs)	-
5	19'200 (default if used with radio communication)	-
6	38'400	-
7	57'600	-
8	115'200 (default for data loggers)	-

**H-G-B-B Parity, stop bits**`generic-rs-485-port-parity-stop-bits`

The following combinations of parity and stop bits can be selected:

ID	Option	Description
1	No par, 1 stop (default)	No parity and 1 stop bit
2	No par, 2 stop	No parity and 2 stop bits
3	Even par, 1 stop	Even parity and 1 stop bit
4	Odd par, 1 stop	Odd parity and 1 stop bit

**H-G-B-C Minimum response time**`generic-rs-485-port-minimum-response-time`

This setting avoids failures of half-duplex interfaces. For this purpose the response to a command is delayed by the selected time. Additionally, the response is also kept temporally compact.

Value range	Default	Units
0...2'000	0	ms

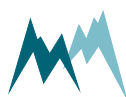

**H-G-B-D Transmitter warm-up time**`generic-rs-485-port-transmitter-warm-up-time`

The transmitter warm-up time defines the time before data is sent.

Value range	Default	Units
0...2'000	10	ms

**H-G-B-E Flow control**`generic-rs-485-port-flow-control`

Flow control for the defined application.

ID	Option	Description
1	Off	no flow control
2	XOFF-XON blocking (default)	XOFF-XON flow control, especially adapted for half-duplex systems



**ATTENTION** To use spectrum mode ([View spectral distribution](#)) set **Flow control** to *XOFF-XON blocking*. This enables a return to normal mode at any time.

**H-G-B-F Sending window**`generic-rs-485-port-sending-window`

If XON-XOFF flow control is activated data are transmitted in blocks with the defined length.

Value range	Default	Units
200...5'000	300	ms

**H-G-B-G Receiving window**`generic-rs-485-port-receiving-window`

If XON-XOFF flow control is activated transmission of blocks is delayed by the specified time.

Value range	Default	Units
200...5'000	300	ms

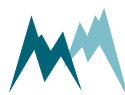

## H-H Advanced settings

H-H-A	Reset general behavior .....	161
H-H-B	Reset total discharge volume .....	161
H-H-C	Inclination measurement .....	162
H-H-D	Sleep mode .....	162
H-H-E	Sommer ID .....	162

### H-H-A Reset general behavior

`generic-reset-behavior`

The RQ-30+ keeps certain sensor data in its memory, e.g. the measured data for calculation of the moving average. This setting defines whether the acquired sensor data are deleted upon a sensor reset or not.

ID	Option	Description
1	hard reset	A reset deletes all acquired and stored sensor data.
2	soft reset (default)	All acquired and stored sensor data are kept for measurements and calculations.



**NOTE** During the installation a hard reset is recommended. After finishing the installation a soft reset should be selected. This shortens start-up time.

### H-H-B Reset total discharge volume

`rq-discharge-reset-total-discharge`

The value of the total discharge volume when the RQ-30+ is restarted (either by re-powering the RQ-30+ or by the function [Relaunch program](#)). By interrupting the power supply of the RQ-30+ this function can be used to reset the total discharge volume in a specified interval.

ID	Option	Description
1	hold value (default)	The last value of the total discharge is set.
2	set to zero	The total discharge is set to zero.

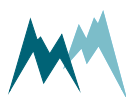

## H-H-C Inclination measurement

rq-discharge-inclination-measurement

The measurement of the flow velocity has to be corrected for the inclination of the RQ-30+ sensor as described in [Inclination angle measurement](#). The following angle corrections are available:

ID	Option	Description
1	first measurement	The inclination is only measured prior to the first measurement after the initialization process (after powering up and after parameter updates)
2	every measurement (default)	The inclination is measured during each velocity measurement.



**ATTENTION** If the inclination of the RQ-30+ sensor can change, i.e. if mounted on a cable way, the inclination should be measured along each velocity measurement.

## H-H-D Sleep mode

generic-sleep-mode

Defines the behavior of the RQ-30+ between two measurements, provided the measurement interval is longer than the time of the measurement itself. The following options are available:

ID	Option	Description
1	MODBUS, fast	For MODBUS applications. The RQ-30+ stays in normal mode. This option permits high data transmission rates, but increases power consumption.
2	MODBUS, slow	For MODBUS applications. The RQ-30+ goes into idle mode and can be woken up by a command via the RS-485 interface with a low baud rate. This option reduces power consumption at lower data transmission rates.
3	Standard (default)	The RQ-30+ goes into sleep mode and can be woken up by a command via the RS-485 interface only with a time delay. Option with the lowest power consumption.

## H-H-E Sommer ID

generic-sommer-id



The Sommer ID is used to define stations within the Q-Commander software. The ID is preset in the device and corresponds to its serial number. SOMMER suggests not to change the ID, except if a RQ-30+ device is replaced. In such a case it can be practical to change the ID of the new device to the ID of the replaced device to guarantee data consistency.

**H-I Tech. AUX**

H-I-A Status ..... 163  
 H-I-B Supply ..... 163  
 H-I-C Warm-up time ..... 164  
 H-I-D 0-2.5 V input span ..... 164  
 H-I-E 0 V input value ..... 164

**H-I-A Status**

`rq-analog-in-status`

Activity status of the auxiliary analog sensor input. If no sensor is connected set to off.

ID	Option	Description
1	off = SFCH (self-check, default)	AUX input is off and the RQ-30+ returns the self-check value.
2	on = AUX	AUX input is on.

**H-I-B Supply**

`rq-analog-in-supply`

Configuration of the sensor power supply.

ID	Option	Description
1	Switched	Sensor power supply is only switched on for measurements. Recommended to minimize power consumption.
2	Always on	Sensor power supply is always on.
3	Always off (default)	Sensor power supply is always off.

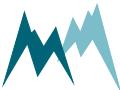

## H-I-C Warm-up time

rq-analog-in-warm-up-time

Delay between power-up of the sensor supply and the return of the measurement.

Value range	Default	Units
0...255	3	Seconds

## H-I-D 0-2.5 V input span

rq-analog-in-2.5v-input-span

The value range of the measured quantity that corresponds to the 0...2.5 V input.

Value range	Default	Units
-99999.99...999999.99	100	Unit of auxiliary sensor quantity

## H-I-E 0 V input value

rq-analog-in-input-value-0v

This value of the measured quantity that corresponds to the 0 V input.

Value range	Default	Units
-99999.99...999999.99	-20	Unit of auxiliary sensor quantity

## H-J Tech. level (W)

This submenu contains the technical parameters for the water level measurement.

H-J-A	Supply .....	164
H-J-B	Warm-up time .....	165

### H-J-A Supply

rq-discharge-supply

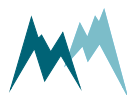

For an efficient energy management the power supply mode of the water level sensor can be set to one of the following options:

ID	Option	Description
1	Switched (default)	Sensor power supply is only switched on for measurements.
2	Always on	Sensor power supply is always on.
3	Always off	Sensor power supply is always off.  <b>ATTENTION</b> This option deactivates the level sensor! Only use it if the level sensor is supplied by an external power source!

### H-J-B Warm-up time

`rq-discharge-warm-up-time`

The time between power-up of the sensor and the first measurement. The water level sensor requires 60 s before valid measurements are returned. Thus, for the switched power supply mode the warm-up time has to be at least 60 seconds.

The figure below illustrates the measurement sequence of the RQ-30+ including the warm-up time of the level sensor.

Value range	Default	Units
0...255	30	Seconds

### H-K Tech. velocity (v)

This submenu contains the technical parameters for the velocity measurement.

H-K-A	Minimum velocity .....	166
H-K-B	Maximum velocity .....	166
H-K-C	Meas. spot optimization .....	166
H-K-D	Measurement type .....	168
H-K-E	Stop, min. quality (SNR) .....	169
H-K-F	Stop, max. opp. direction .....	169
H-K-G	Stop, number of valid meas. ....	169
H-K-H	Stop, behavior .....	170
H-K-I	Stop, replace value .....	171
H-K-J	Start velocity at WLL .....	171
H-K-K	Velocity output .....	171
H-K-L	Meas. spot weighting .....	171

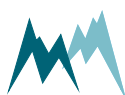

## H-K-A Minimum velocity

`rq-discharge-minimum-velocity`

The minimum velocity defines the lower limit for the velocity determination by spectral analysis.



### ATTENTION

The flow velocity of the river or canal should be significantly higher than 150% of the **Minimum velocity**.

Value range	Default	Units
0...1.5	0.07	m/s

## H-K-B Maximum velocity

`rq-discharge-maximum-velocity`

The maximum velocity defines the upper limit of expected velocities. The velocity measurement is optimized for this setting. Usually a value of 5000 mm/s (5 m/s) is adequate. No extra margin has to be accounted for as this is included in the RQ-30+ sensor by default.

Value range	Default	Units
0...15	7	m/s

## H-K-C Meas. spot optimization

`rq-discharge-meas-spot-optimization`

Inactive if parameter **Channel type** is set to covered.

This parameter describes the expected flow velocity distribution within the measurement spot (see [Figure 24](#)). For a more heterogeneous flow distribution a wider spectral band width has to be selected. The options are as follows:



ID	Option	Description
1	very constant veloc.	homogenous water surface, small bandwidth
2	standard (default)	heterogeneous water surface, wide bandwidth
3	bank area	heterogeneous water surface with very different velocities, very wide bandwidth
4	splash water	Splashing water surface, full bandwidth

Generally, the option *standard* is recommended.

A calm river has a small flow velocity range, and the corresponding option *very constant veloc.* restricts the velocity evaluation to a narrow peak. On the other hand, a rough river has a large flow velocity range, and the corresponding option *splash water* extends the velocity evaluation to a wide peak.

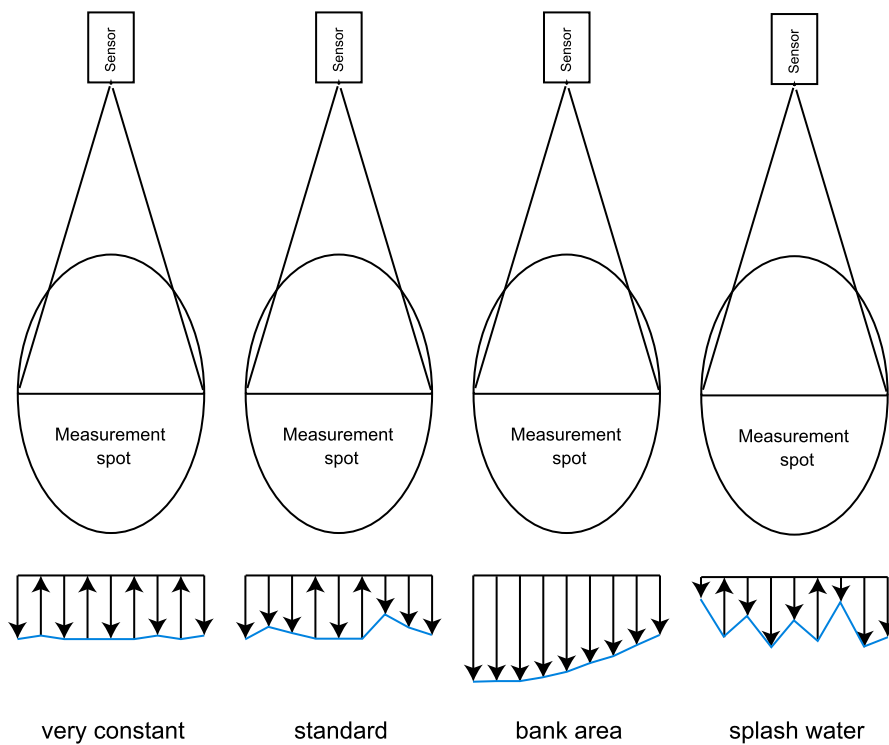
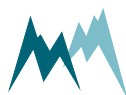

Figure 24 Measurement spot optimization concepts



**NOTE**

The flow characteristics of a river generally change significantly with changing water levels. We therefore recommend to set the default option *standard* to avoid larger uncertainties associated with wide velocity peaks.

**H-K-D Measurement type**

rq-discharge-measurement-type

The flow velocity can be measured by two different methods:

ID	Option	Description
1	continuous (default)	The measurement is performed in one piece.
2	sequenced	The measurement is split into five parts.

**Continuous measurement type**

The flow velocity measurement is performed continuously in one piece. This has the advantage of a fast measurement with little energy consumption. However, for highly fluctuating velocities the measurement time has to be increased considerably to gain accurate results.

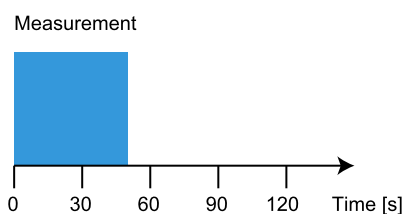
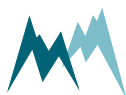

Figure 25 Continuous measurement type

**Sequenced measurement type**

The flow velocity measurement is divided into five sub-intervals of random length summing up to the specified measurement duration. This increases the complete measurement duration without increasing energy consumption. Thus, this method provides more accurate results for highly fluctuating velocities.



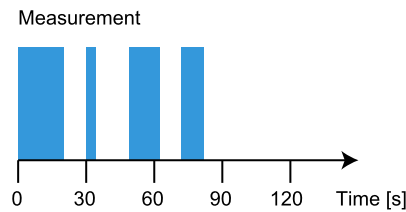

Figure 26 Sequenced measurement type

### H-K-E Stop, min. quality (SNR)

`rq-discharge-stop-min-quality`

This parameter defines the lower limit of the quality value, expressed by SNR. Flow velocities below this quality value are identified as invalid. Invalid measurements are handled according to the behavior set in [Stop, behavior](#).

A measurement with a low SNR occurs if the velocity is below the detection limit. It is recommended to set this parameter at measurement sites with tidal influence or with back-water and where the velocity can drop to zero.

Value range	Default	Units
7...100	30	-

### H-K-F Stop, max. opp. direction

`rq-discharge-stop-max-opp-direction`

The opposite direction content is the fraction of counter-flow in measurement direction. The parameter defines an upper limit for counter-flow, above which measurements are identified as invalid. Invalid measurements are handled according to the behavior set in [Stop, behavior](#).

Value range	Default	Units
10...1000	150	%

### H-K-G Stop, number of valid meas.

`rq-discharge-stop-number-valid-meas`

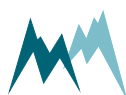

After an invalid measurement has occurred the selected number of valid measurements has to be returned before the measurements are tagged as valid again.

Value range	Default	Units
1...20	1	-

## H-K-H Stop, behavior

`rq-discharge-stop-behaviour`

This parameter defines the handling of invalid measurements. The following options can be set:

ID	Option	Description
1	hold value	The last valid value is returned.
2	use replace value (default)	The replacement value set in <a href="#">Stop, replace value</a> is returned.
3	use learn value	The learned value according to the water level of the W-v relation is returned.



### NOTE

The option *use learn value* should only be used after the RQ-30+ has gained a w-v learning curve over a wide range of water levels. Depending on the dynamic of the river or channel this may take days to months. If the covered range is very small, the RQ-30+ may not be able to compute a learned value.

Use the option *hold value* only if are confident that it reasonably approximates the true flow!

When starting measurements at a new site it is recommended to use the option *replace value* with a distinct value, e.g. *-999*. This enables you to detect any unexpected conditions or behaviors of the flow regime or the setup.



### NOTE

If [Stop, behavior](#) is set to *use learn value* and the W-v table has no or only one entry, the [Stop, replace value](#) will be returned. This can be the case for a newly installed RQ-30+ that has gained velocity data for a narrow water level range only.

### H-K-I Stop, replace value

rq-discharge-stop-replace-value

An invalid measurement is replaced by this value if option 2 in [Stop, behavior](#) is selected.

Value range	Default	Units
-9.999...9.999	0	m/s

### H-K-J Start velocity at WLL

rq-discharge-stop-velocity-wll

If the water level during installation is between the low level border WLL and the flow stop level WCF), the flow velocity can be set with this parameter in order to instantly record discharge values. As soon as the water level is above the low level border WLL this parameter is not relevant any more.

Value range	Default	Units
-9.999...9.999	0	m/s

### H-K-K Velocity output

rq-discharge-velocity-output

The type of velocity returned by the sensor.

ID	Option	Description
1	surface velocity (default)	The velocity is returned as local surface velocity $v_l$ .
2	mean profile veloc.	The velocity is returned as mean velocity $v_m$ ( $v_m = k (W) \cdot v_l$ ).

### H-K-L Meas. spot weighting

rq-discharge-meas-spot-weighting

Weighting factor used to adjust the flow velocity measurement to specific wave characteristics. For most applications the default of zero is applicable. Positive values reduce the flow velocity, negative values increase the velocity. For a river with a rough water surface, a value of 17 may be applied.

Value range	Default	Units
-100...100	0	-

## H-L 4-20 mA outputs

H-L-A	Output status .....	172
H-L-B	IOUT1, AUX 4-20 mA span .....	172
H-L-C	IOUT1, AUX 4 mA value .....	173
H-L-D	IOUT2, level 4-20 mA span .....	173
H-L-E	IOUT2, level 4 mA value .....	173
H-L-F	IOUT3, Max. velocity .....	174
H-L-G	IOUT4, max. discharge .....	174
H-L-H	Simulate current output .....	174

### H-L-A Output status

`generic-analog-out-status`

The status defines the behavior of the analog outputs.

ID	Option	Description
1	Off (default)	Analog outputs are inactive.
2	Just during TRIG	Analog outputs are only active, if an external signal is present at the TRIG input. The outputs are high as long as the signal at the TRIG input is high.
3	Always on	Analog outputs are permanently active.

### H-L-B IOUT1, AUX 4-20 mA span

`rq-analog-out-iout1-aux-span`

The output range of the 4-20 mA signal for the measured quantity.

Value range	Default	Units
-99999.99...999999.99	100	Unit of auxiliary sensor quantity

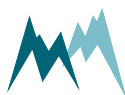

**H-L-C IOOUT1, AUX 4 mA value**

rq-analog-out-iout1-aux-4ma-value

This value of the measured quantity that corresponds to the 4 mA output.

Value range	Default	Units
-99999.99...999999.99	-20	Unit of auxiliary sensor quantity

**H-L-D IOOUT2, level 4-20 mA span**

rq-analog-out-iout2-level-span

The output range of the 4-20 mA signal for the water level. The span should cover the complete water level range that is expected.

Value range	Default	Units
-9999999...999999999	15/30	Unit of water level

**EXAMPLE**

Minimum expected water level: 120 mm

Maximum expected water level: 1450 mm

Water level span: 1330 mm

**IOOUT2, level 4-20 mA span:** 1600 (a change of 100 mm corresponds to a change of 1 mA)

**IOOUT2, level 4 mA value:** 0

In some cases it may be required to report the distance to the water surface instead of the water level. This can be achieved with the following settings:

**IOOUT2, level 4-20 mA span:** -1600 mm

**IOOUT2, level 4 mA value:** 1600 mm

**H-L-E IOOUT2, level 4 mA value**

rq-analog-out-iout2-level-4ma-value

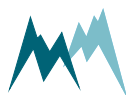

This minimum water level that corresponds to the 4 mA current output. The value should be below the lowest expected water level and should be easily interpretable.

Value range	Default	Units
-99999.99...999999.99	0	Unit of water level

### H-L-F IOOUT3, Max. velocity

`rq-analog-out-iout3-max-velocity`

The maximum velocity that corresponds to the 20 mA current output. The 4 mA output is predefined to correspond to a velocity of 0.

Value range	Default	Units
-99999.99...999999.99	10	Unit of velocity

### H-L-G IOOUT4, max. discharge

`rq-analog-out-iout4-max-discharge`

This maximum discharge that corresponds to the 20 mA current output. The 4 mA output is predefined to correspond to a discharge of 0.

Value range	Default	Units
-99999.99...999999.99	100	Unit of discharge

### H-L-H Simulate current output

`generic-analog-out-simulate-current`

With this function the analog outputs can be simulated. Upon submission of a current value between 4 and 20 mA the corresponding values of the selected variable are displayed. The selected current is also applied to the active analog outputs and can be read with a connected data logger or multimeter. By pressing Return/Enter again the simulation stops.



#### NOTE

If **Output status** is deactivated, no current output can be simulated.



If **Output status** is set to **just during TRIG**, the trigger must be set prior to simulation. Additionally, the trigger must be reset before each simulation.

## I Region format

I-A	Language/Sprache .....	175
I-B	Decimal character .....	175

### I-A Language/Sprache

`generic-language`

The menu language.

ID	Option	Description
1	German/Deutsch	German language
2	English/Englisch (default)	English language

### I-B Decimal character

`generic-decimals-character`

The character used as decimal separator in the values of the settings, in serial data strings and in .csv files.

ID	Option	Description
1	Comma	-
2	Dot (default)	-

## J Special functions

J-A	View spectral distribution .....	176
J-B	Veloc. radar inspection (Som) .....	176
J-C	Veloc. radar inspection (RFB) .....	176
J-D	Continuous meas. mode (temp). .....	176

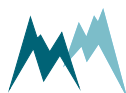

J-E	View spectral trap .....	176
J-F	View setup .....	177
J-G	Device status .....	177
J-H	W-v table view .....	177
J-I	W-v table reset .....	177
J-J	Set factory default .....	177
J-K	Temp. load factory default .....	178
J-L	Relaunch program .....	178
J-M	Replace program .....	178

## J-A View spectral distribution

`generic-special-functions-view-spectral-distribution`

With this command the sensor is set into spectral mode. After 30 minutes the spectral mode is switched off automatically.

With the Q-Commander software the spectra can be recorded, visualized and stored for expert analysis of the sensor signal, e.g. additional reflections.

## J-B Veloc. radar inspection (Som)

`rq-discharge-veloc-radar-inspection`

Diagnostic tool for in-depth device analysis. Inactive, for in-house use only.

## J-C Veloc. radar inspection (RFB)

`rq-discharge-veloc-radar-inspection-rfb`

Diagnostic tool for in-depth device analysis. Inactive, for in-house use only.

## J-D Continuous meas. mode (temp).

`generic-special-functions-continuous-meas-mode`

Inactive in the Q-Commander menu. This feature can be triggered in the Q-Commander under the **Measurement (F3)** tab with the command **Start polling measurements** and then **Start polling WITH measurements**. When active, measurements are performed continuously, ignoring the specified measurement interval.

## J-E View spectral trap

`rq-discharge-view-spectral-trap`

For expert use only! Inactive in the Q-Commander menu.

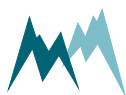

The integrated velocity radar sensor has the option to save the spectra of special events. This command returns these spectra. One output contains four spectra.

Index	Option	Description
1	Stop	Spectrum of the last invalid measurement caused by a Stop event.
2	Reference	Spectrum of the measurement performed before the last event.
3	Trap	Spectrum of the measurement of the last event with the velocity increase according to menu item <a href="#">Spectral trap, veloc. rise</a> .
4	Normal	Actual spectrum

## J-F View setup

```
generic-special-functions-view-setup
```

All parameters of the RQ-30+ are listed in the terminal window.

## J-G Device status

```
generic-special-functions-device-status
```

Displays information about the device and the software version.

## J-H W-v table view

```
rq-discharge-w-v-table-view
```

The learned W-v table is listed in the terminal window. Only available in terminal mode.

## J-I W-v table reset

```
rq-discharge-w-v-table-reset
```

The learned W-v table is completely deleted and re-initiated.

## J-J Set factory default

```
generic-special-functions-set-factory-default
```

All parameters are reset to factory defaults. Only available in terminal-mode.

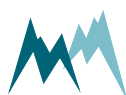

## J-K Temp. load factory default

`generic-special-functions-temp-load-factory-default`

Loads factory default values temporarily. Only available in terminal mode.

## J-L Relaunch program

`generic-special-functions-relaunch-program`

The device is restarted. Powering the device off and on again is equivalent.

## J-M Replace program

`generic-special-functions-replace-program`

The device is set into a "Boot Loader" mode for three minutes to upload new software remotely in case supply off and on again is not applicable.

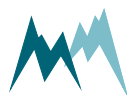

## 15 Replacement parts

ID	Art. Nr.	Description	Comment
1	17184	RQ-30a System for contact-free discharge measurement with analog output	Needs to be set to 15 or 35 m at factory
2	21848	Radar level sensor 0...15 m with connector	15-m version only
	21609	Upgrade kit from VEGA WL61 to SOMLEVEL-15	15-m version only Includes - 15951 - 2 x 15958 - 1m Cable - Mounting
	20720	Radar water level sensor 0...35 m with connector	35-m version only Includes - 15951 - 2 x 15958 - 17903 - Cable
	17903	Mounting bolt for Vega level sensor	35-m version only
3	15951	Plastic cable plug Trim-Trio, UTS IP68/IP69K with back shell for pin contacts, shell size 10, 4P, ROHS	Plug for water level sensor
	2 x 15958	Interconnection, Trim-Trio, ROHS	
4	21491	Adapter SOMLEVEL-15 for RQ-30	15-m version only
5	18011	Mounting plate for U-blots	
6	20074	Mounting set for RG/RQ	Includes 2xU-Bolts for max DM 60mm, Nuts
7	18016	Housing cover RQ-30	
8	21492	Adapter plate for SOMLEVEL-15 in RQ-30	
9	18711	Data cable for RQ-30 / RG-30, LiYCY 12x0,25mm <sup>2</sup> , 10 m	
	18712	Data cable for RQ-30 / RG-30, LiYCY 12x0,25mm <sup>2</sup> , 20 m	

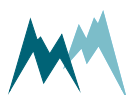

ID	Art. Nr.	Description	Comment
10	15954	Plastic cable plug Trim-Trio, UTS IP68/IP69K with back shell female, 12P, ROHS	Sensor plug
	12 x 15957	Interconnection, Trim-Trio, ROHS	
11	18013	Housing RQ-30	Includes - side walls - bottom plate - back plate

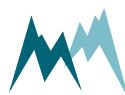
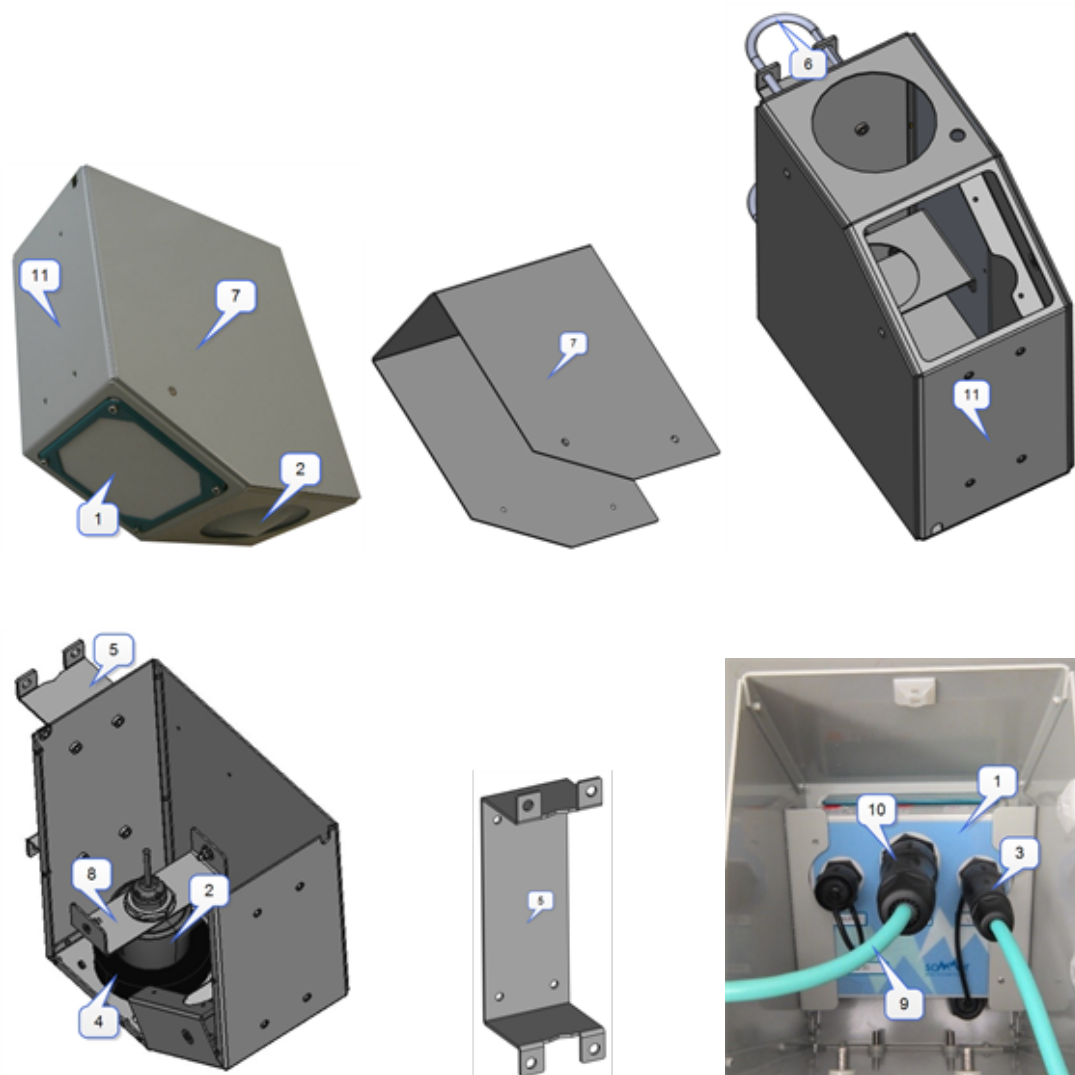

## Appendix A Troubleshooting

A.1	Devices .....	181
A.1.1	The RQ-30+ is not responding or returns unreadable characters .....	181
A.1.2	The RQ-30+ reboots repeatedly .....	183
A.2	Measurement data .....	183
A.2.1	Measurement data are not updated .....	183
A.2.2	The RQ-30+ returns no or zero velocity .....	184
A.2.3	The RQ-30+ returns negative velocities .....	184
1.2.4	The RQ-30+ returns the wrong water level .....	185
A.2.5	The RQ-30+ continuously returns the same water level .....	185
1.2.6	The RQ-30+ returns no water discharge .....	186
A.2.7	The measured discharge is too low or too high .....	186
A.2.8	The RQ-30+ returns negative discharge values .....	187
1.2.9	The discharge sum is reset regularly .....	188
A.2.10	Learned velocity and discharge are inconsistent .....	188
1.2.11	Quality values are low or negative .....	188
1.2.12	Velocity/level data show spikes .....	189
A.2.13	W-v table reset fails .....	189
A.3	Firmware & software .....	189
A.3.1	Commander loads wrong setup .....	189
A.3.2	Firmware update via RS-485 is aborted .....	190
A.4	RS-485 .....	190
A.4.1	Configuration via terminal shows unexpected behavior .....	190
A.5	SDI-12 .....	190
A.5.1	The RQ-30+ is not detected by a SDI-12 master device .....	190
A.6	Modbus .....	191
A.6.1	Modbus function 04 returns obscure measurement values .....	191
A.7	Analog output .....	192
A.7.1	The 4-20 mA output is wrong .....	192

### A.1 Devices

#### A.1.1 The RQ-30+ is not responding or returns unreadable characters

Reason	Solution
The power supply is not connected or turned off.	Check if the power supply is connected and on.
The polarity of connected power supply wires is wrong.	Check the polarity of connected wires.
Wrong sensor cable.	Use the original sensor cable configured by Sommer Messtechnik (only applicable to Sommer Messtechnik cables).

Reason	Solution
Power supply is insufficient. The RQ-30+ requires a certain inrush-current that the power supply is not able to provide.	<ol style="list-style-type: none"> <li>1. Use a power supply providing &gt;0.5 A at 12 VDC or a fully charged battery.</li> <li>2. In case of long sensor cables (&gt;50 m) use a 24-VDC power supply.</li> </ol> <p>Please note that power supplied by the USB-port is insufficient to power the RQ-30+!</p>
The power supply voltage is out of range.	Adjust the power supply to match the specified voltage range.
The polarity of the connected RS-485-A and RS-485-B wires is wrong.	Reverse the polarity of the connected RS-485-A and RS-485-B wires.
The port settings of the RQ-30+ and the data acquisition system do not match.	<p>Use the Q-Commander <b>Communication assistant</b> or adapt port settings on your device.</p> <div style="border-left: 2px solid #0070C0; padding-left: 10px; margin-top: 10px;"> <p> <b>NOTE</b> Sommer Messtechnik devices require the following Baud rates:</p> <ul style="list-style-type: none"> <li>■ Sensor: 9600</li> <li>■ Data logger: 115200</li> <li>■ Modbus: 19200</li> </ul> <p>In case of doubt use the function <b>Check port</b> in the <b>Communication assistant</b>.</p> </div>
The RQ-30+ is set to Modbus.	Connect to the sensor using the Communication assistant of the Q-Commander and select the <b>Modbus</b> option in the <b>Serial connection</b> .
A sensor wire is not connected firmly to the terminal of the data acquisition device.	Check the firm connection of the sensor wires.
RQ-30+ and data acquisition device have different grounds.	Connect the grounds of the RQ-30+ and the data acquisition device.
A pin of the connector plug is bent or broken.	Verify that all connector pins are straight.
The sensor cable is damaged.	Replace the sensor cable.

Reason	Solution
The COM-port has not been assigned correctly to the USB converter.	<ol style="list-style-type: none"> <li>1. Make sure to use a Sommer Messtechnik USB converter. Third party converters are not supported.</li> <li>2. Check the COM-port number using <a href="#">Windows Device Manager</a>.</li> <li>3. Plug in the USB converter first, then start Q-Commander.</li> </ol>
The USB converter is faulty.	Replace the USB converter.
The USB port on your PC is not working.	Use another USB port.
The driver of the USB converter was incorrectly installed	Reinstall the driver of the USB converter.

### A.1.2 The RQ-30+ reboots repeatedly

Reason	Solution
The power supply has not enough current to start the RQ-30+.	Verify that the power supply provides enough current. A RQ-30+ consumes up to 140 mA @ 12 V. If required, power the RQ-30+ by an additional or alternative supply.

## A.2 Measurement data

### A.2.1 Measurement data are not updated

The device is connected to the Q-Commander, but the data are not updated.

Cause	Solution
Data traffic conflict	Reboot the device by interrupting the power supply.
The RQ-30+ was powered while the target of the level sensor was within its blanking distance.	Verify that the target is outside the blanking distance of the level sensor and reboot the device by interrupting the power supply.

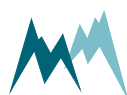

## A.2.2 The RQ-30+ returns no or zero velocity

Reason	Solution
Water level has not been adjusted.	Perform a water level adjustment.
WLL, low level border is too high.	Verify correct setting of WLL, low level border.
RQ-30+ position and/or sensor settings do not match water flow conditions.	<ol style="list-style-type: none"> <li>1. Check settings in menu <b>Velocity</b>.</li> <li>2. Check value of <b>Quality (SNR)</b> returned by the RQ-30+.</li> <li>3. Check value of <b>Opposite direction</b> returned by the RQ-30+. Increase <b>Stop, max. opp. direction</b>.</li> <li>4. Increase or decrease the vertical mounting position of the RQ-30+.</li> <li>5. Reverse the viewing direction of the RQ-30+ and adapt the setting <b>Viewing direction</b>.</li> </ol>
Waves on water surface are insufficient	<ol style="list-style-type: none"> <li>1. Create surface waves using a chain, rope or other means upstream of the measurement spot.</li> <li>2. If waves on the water surface look sufficient, toggle <b>Channel type</b> to open or vice versa.</li> <li>3. Increase <b>Measurement duration</b> up to 60 s.</li> </ol>

## A.2.3 The RQ-30+ returns negative velocities

Reason	Solution
<b>Stop, behavior</b> is set to <i>use replace value</i>	Set <b>Stop, behavior</b> to <i>use learn value</i> or <i>hold</i> , or change <b>Stop, replace value</b> .
<b>Stop, behavior</b> is set to <i>use learn value</i> , but w-v table contains negative velocities. This may occur after a test period when different settings were applied or the sensor position was changed. This behavior may also appear if the learning period has been too short, i.e. the w-v table contains only one entry. In this case the RQ-30+ cannot determine a learned velocity and uses the replace value instead.	Reset the w-v table with the function <b>W-v table reset</b> in the menu <b>Special functions</b> . Set <b>Stop, behavior</b> to <i>hold</i> or <i>use replace value</i> with an appropriate value; change to <i>use learn value</i> as soon as the RQ-30+ the w-v table has gained multiple entries (use <b>W-v table view</b> to check).

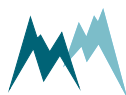

### 1.2.4 The RQ-30+ returns the wrong water level

Reason	Solution
Water level is not adjusted properly.	<p>Perform a water level adjustment.</p>  <p><b>NOTE</b> The water level is the vertical distance between the deepest point of canal/river and the water surface.</p>
The RQ-30+ is installed improperly and/or water level settings are inappropriate.	<ol style="list-style-type: none"> <li>1. Verify that the RQ-30+ is mounted within its measurement range (see ).</li> <li>2. Verify that the RQ-30+ is installed parallel to the water surface.</li> <li>3. Make sure that no obstacles extend into the measurement beam.</li> <li>4. Deactivate the moving data filter (<b>Filter, no. of values</b>).</li> <li>5. Perform a level test and verify the correct reading.</li> <li>6. Switch <b>Supply</b> to <i>always on</i>.</li> <li>7. Verify units and decimals of water level.</li> </ol>

### A.2.5 The RQ-30+ continuously returns the same water level

Reason	Solution
<b>Supply</b> in setup menu <b>Tech. level (W)</b> is set to <i>always on</i> .	Change setting to <i>switched</i> . If set to <i>always on</i> , the level sensor of the RQ-30+ does not receive the measurement trigger.
The water level is outside the measurement range of the RQ-30+.	Check the water level with the function <b>Test</b> in setup menu <b>Level (W)</b> . Check the values of <b>WCF, cease to flow level</b> and <b>WMA, maximum level</b> . If these levels are different from <b>0</b> , the measured water level must be within the range of these two settings. Otherwise, the RQ-30+ returns the hold value.
The unit of the water level is <i>m</i> or <i>ft</i> and the decimals are <b>0</b> . Thus, small changes in water levels are not resolved.	Change the unit to <i>mm</i> or <i>in</i> , or add decimals.

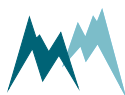

## 1.2.6 The RQ-30+ returns no water discharge

Reason	Solution
The RQ-30+ does not have the correct cross-sectional profile available.	<ol style="list-style-type: none"> <li>1. Verify that the measured water level is within the range covered by the cross sectional profile.</li> <li>2. Upload the cross-sectional profile again.</li> </ol>
Water level has not been adjusted.	Perform a water level adjustment.
WLL, low level border is set too high.	Verify that <b>WLL, low level border</b> is correct.
The RQ-30+ does not detect the flow velocity.	<ol style="list-style-type: none"> <li>1. Verify that the flow velocity reading is correct.</li> <li>2. Check <b>Velocity</b> settings.</li> <li>3. Check <b>Quality (SNR)</b> returned by the RQ-30+.</li> <li>4. Check <b>Opposite direction</b> and increase <b>Stop, max. opp. direction</b>.</li> </ol>
Units and decimals of water discharge are inappropriate	Verify that units and decimals of water discharge are suitable.

## A.2.7 The measured discharge is too low or too high

Reason	Solution
The RQ-30+ reports a self-check code >5.	Work off the self-check codes as described in <b>Device status</b> .
The orientation of the RQ-30+ is not parallel to the flow direction.	Turn the RQ-30+ parallel to the flow direction.
The RQ-30+ is not parallel to the water surface.	Tilt the RQ-30+ until it is parallel to the water surface. If you cannot tilt the sensor, enter the angle between the sensor and the water surface into <b>River inclination</b> .
Opposite direction content is too high.	<ul style="list-style-type: none"> <li>- Reverse the orientation of the RQ-30+ and set <b>Viewing direction</b> accordingly.</li> <li>- Move the RQ-30+ to a different position.</li> </ul>

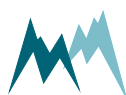

Reason	Solution
Cross-sectional profile is wrong or out of date.	Correct the cross-sectional profile. <ul style="list-style-type: none"> <li>- Does the profile represent the current cross-section?</li> <li>- Is the profile high enough to contain the highest expected water levels?</li> <li>- Is the zero water level at the deepest point of the profile?</li> <li>- Is the sensor position correct?</li> <li>- Is the roughness correct?</li> </ul>
The RQ-30+ has an outdated discharge table.	Upload the discharge table to the RQ-30+ again.
The water level is incorrect.	Perform a water level adjustment. Make sure the water level is measured correctly: from the deepest point to the water surface.
Velocity measurement duration is too short.	Increase <b>Measurement duration</b> by 10 to 20 s.
<b>Minimum velocity</b> is set too high.	Decrease <b>Minimum velocity</b> to min. 0.8 m/s.
Channel type selected in Q-Commander is inappropriate.	Change <b>Channel type</b> from open to closed or vice versa.
Clogging or an obstruction is creating back-water.	Verify that the water below the RQ-30+ is free flowing.
The water flow conditions are outside the limits of the radar sensor, e.g., <ul style="list-style-type: none"> <li>- Extremely slow moving water</li> <li>- Glassy surface with no ripples</li> <li>- Extremely turbulent water (white water)</li> <li>- Water flow with intense vortices</li> </ul>	Change the measurement site.

### A.2.8 The RQ-30+ returns negative discharge values

Reason	Solution
The RQ-30+ records negative velocities.	See <a href="#">The RQ-30+ returns negative velocities.</a>

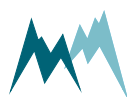

### 1.2.9 The discharge sum is reset regularly

Reason	Solution
The power supply of the RQ-30+ is interrupted regularly (e.g. the data logger performs a daily reset) and <b>Reset general behavior</b> is set to <i>Hard reset</i> .	Set <b>Reset general behavior</b> to <i>Soft reset</i> , or disable power interruption by the data acquisition system (see also troubleshooting section of MRL manual).

### A.2.10 Learned velocity and discharge are inconsistent

Reason	Solution
The learned discharge table (W-v table) contains data from previous measurement campaigns.	Click <b>W-v table view</b> in the menu <b>Special functions</b> to display the content of the W-v table. Check the consistency of the listed data. If required, click <b>W-v table reset</b> to build the learned discharge table anew.

### 1.2.11 Quality values are low or negative

Reason	Solution
Opposite direction content is high (> 150%)	Reverse viewing direction
Wind generates a secondary wave pattern	<ul style="list-style-type: none"> <li>■ Select a different monitoring location</li> <li>■ If wind is not a permanent issue: Set <b>Stop, max. opp. direction</b> in menu <b>Technics &gt; Tech.velocity</b> to about 150% and allow the RQ-30+ to fill the learned discharge table. This may take several weeks to month, depending on the water level variation of the river/canal. After the learning time, increase <b>Stop, max. opp. direction</b> to about 250% or more.</li> </ul>



### 1.2.12 Velocity/level data show spikes

Reason	Solution
Water surface is rough.	<ol style="list-style-type: none"> <li>1. Verify if spikes are plausible. If a single spike extends over multiple measurements, the observed shift may be real.</li> <li>2. Apply a moving data filter (see <a href="#">Velocity</a> ).</li> <li>3. Increase <a href="#">Measurement duration</a> up to 60 s.</li> </ol>

### A.2.13 W-v table reset fails

After clicking [W-v table reset](#), the reset process is aborted and the W-v table is not updated.

Cause	Solution
The RQ-30+ is connected to an MRL data logger and the <a href="#">Flow control</a> of the RQ-30+ and the MRL do not match.	Make sure the <a href="#">Flow control</a> of sensor and logger match. Generally, this is <i>XOFF-XON blocking</i> .

## A.3 Firmware & software

### A.3.1 Commander loads wrong setup

If the setup is reloaded from the device the Q-Commander seems to display an old version.

Cause	Solution
The device has been connected to the same PC before and several different setup files have been loaded.	<ul style="list-style-type: none"> <li>■ In the <a href="#">Communication</a> section of the Q-Commander, select <a href="#">Mode Connection</a> and click on the trash can icon on the right edge. Then, reload the setup from the device.</li> <li>■ Delete the setup files of the device that have been downloaded by Q-Commander to the folder <i>C:\Users\Public\Documents\Sommer\Setup</i>. The respective files can be identified by the serial number in the file name and the file date.</li> </ul>

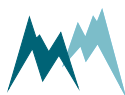

### A.3.2 Firmware update via RS-485 is aborted

Reason	Solution
USB to RS-485 converter cable is damaged or can only operate on 9600 baud.	Replace USB to RS-485 converter cable. The programmer requires 57600 baud.

## A.4 RS-485

### A.4.1 Configuration via terminal shows unexpected behavior

Accessing the parameter menus in the terminal leads to unexpected behavior, e.g. after entering a menu character the terminal displays repeated error messages or jumps out of the parameter menu.

Reason	Solution
The sensor, power supply and PC/laptop do not share the same ground.	Verify that all equipment is connected to the same ground.

## A.5 SDI-12

### A.5.1 The RQ-30+ is not detected by a SDI-12 master device

Reason	Solution
The RQ-30+ and the SDI-12 master have different grounds.	Verify that the RQ-30+ and the SDI-12 master are connected by a ground (GND) wire.

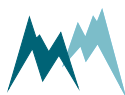

## A.6 Modbus

### A.6.1 Modbus function 04 returns obscure measurement values

Reason	Solution
Sensor does not run in its own measurement interval, i.e., <b>MeasuremenSet Mt trigger</b> is not set to <i>Interval</i> .	Set <b>Measurement trigger</b> of the sensor to <i>Interval</i> . A Modbus master can only read measurement data, it cannot trigger measurements.
A second Modbus master is present in the RS-485 bus.	Make sure that only one Modbus master is communicating with the Modbus slaves.
Port settings of Modbus master and slave do not match.	Verify that port settings of Modbus master and slave match. Generally, the port settings are 19200, even par, 1 stop, no flow control.
The Modbus master does not read the input register (function 04, protocol address 3xxx).	Verify that the Modbus master reads the input register.
The Modbus master reads the wrong registers. Depending on the Modbus master, register numbering may start at 0 or 1. For example, a measurement value is on input register 02. This corresponds to the protocol address 30002 or 30003.	Increment the register address by 1 if you don't know the numbering base of the Modbus master.
The returned hex-value is converted to the wrong data type.	Generally, measurement values are 4-byte floats. Verify that values are converted to float, not decimal or any other type.
Endianness of the Modbus polling unit is swapped. Generally, test values and measurement values are set to big endian. Older firmware versions may return measurement values as little endian.	If the device runs on an older firmware, convert the measurement values to float with little endian.
The signal wires between the Modbus master and the slaves are long and/or the ground potentials of the devices are different.	<ul style="list-style-type: none"> <li>■ Connect the grounds of the devices with an additional wire.</li> <li>■ Reduce the cable length.</li> </ul>

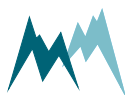

## A.7 Analog output

### A.7.1 The 4-20 mA output is wrong

Reason	Solution
Analog output settings incorrect.	<ol style="list-style-type: none"> <li>1. Check analog output settings.</li> <li>2. Run <a href="#">Simulate current output</a> and verify the correct output.</li> </ol>
Sensor and data acquisition system have different grounds.	Verify that sensor and data acquisition system have the same ground.
The analog output is read by a data acquisition system and the scaling is wrong.	Verify scale and offset on your data acquisition system.
Two or more analog outputs of the RQ-30+ are read by a data acquisition system and the wiring is wrong, e.g. IOUT1 is read as IOUT2.	Verify the wiring on your data acquisition system and swap the wires if required.
The 4-20 mA output is delayed by approx. 150 ms. If the output is read before, a wrong value is acquired.	Sample the 4-20 mA output with a delay of more than 150 ms.

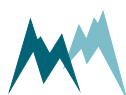

# Appendix B Unwanted reflections

## B.1 Open channel

Depending on the dimensions of the water channel in which the RQ-30+ sensor is installed in, unwanted reflections may occur and distort the velocity spectrum. Such reflections can be detected by looking at a recorded velocity spectrum as shown in the following example:

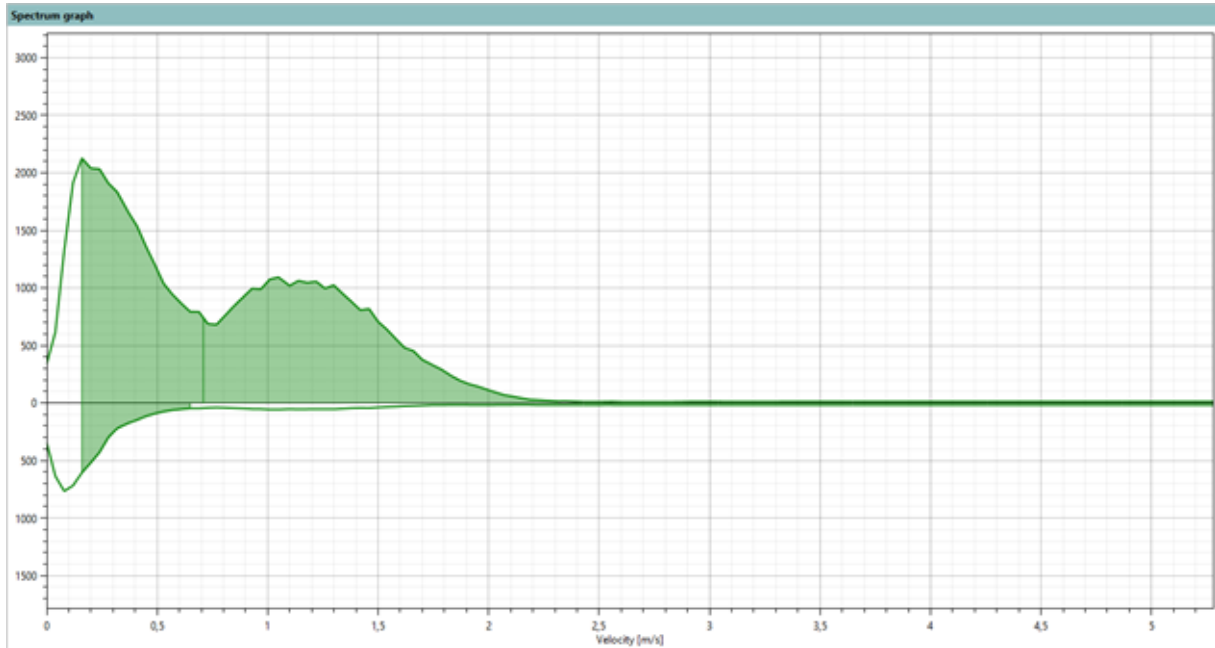

Figure 1 Velocity spectrum containing unwanted reflections



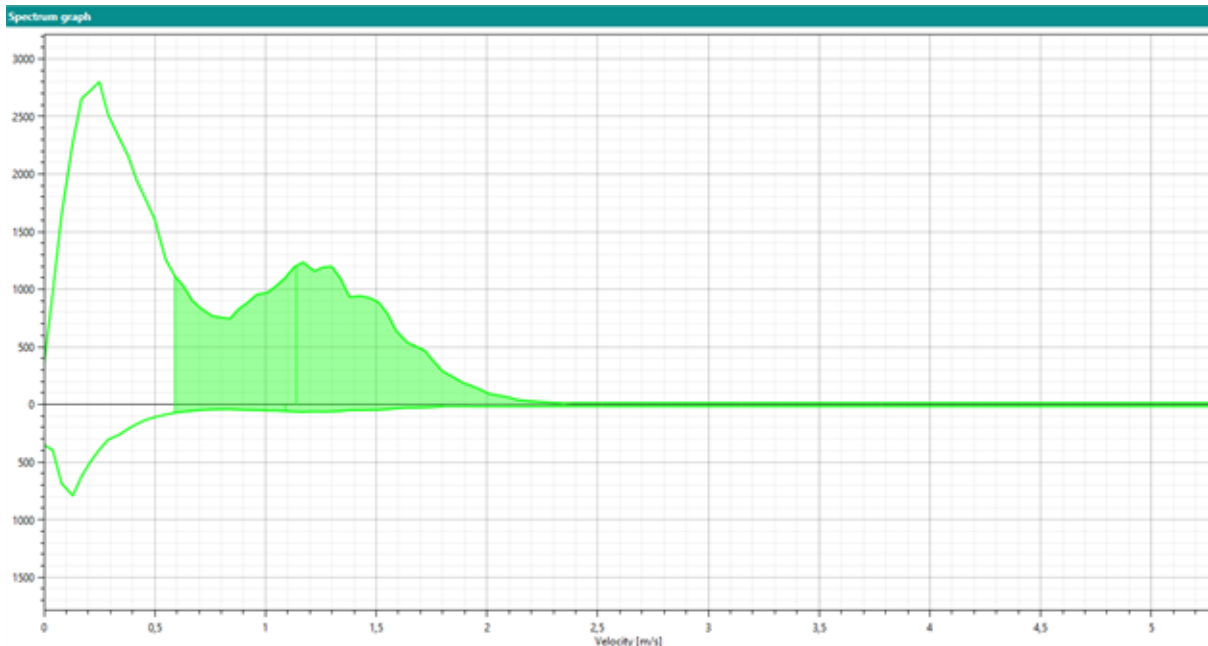

Figure 2 Velocity spectrum with adjusted minimum velocity

In the spectrum of Figure 1 two peaks can be observed: The first at approximately 0.15 m/s and the second at approx. 1.2 m/s. The shaded area is considered by the implemented algorithm to calculate the flow velocity. In this example the sensor determined a velocity of 0.71 m/s.

A second, independent measurement at the site revealed a flow velocity of 1.1 ... 1.2 m/s. The discrepancy between these two results can be attributed to reflections on the channel wall, which caused a secondary peak in the spectrum at 0.15 m/s.

This means the first peak in the spectrum (at 0.15 m/s) is caused by an unwanted reflection in the channel where the RQ-30+ is installed. The result is that the algorithm implemented in the RQ-30+ is not able to determine the correct velocity. Due to the low velocity of the first peak the determined (and output-ted) velocity is lower than the real velocity:

To suppress this undesired behavior the setting **Minimum velocity** has to be set to a velocity higher than that of the first peak. Appendix B shows the result of this procedure: The first peak is not shaded anymore, meaning it is not considered for the velocity calculation. Only the second peak is used by the algorithm and the calculated flow velocity of 1.15 m/s is in agreement with the velocity of the comparison measurement.

## B.2 Closed channel

The example described above is valid for open channels only. If the RQ-30+ sensor is applied in a closed channel and the configuration **Channel type** is set to closed the first peak in the velocity spec-

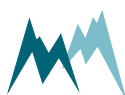

trum is ignored. This peak results from reflections at the channel wall is removed before the velocity calculation.

## 2.3 Examples of velocity spectra

The images below show different spectra as they are encountered in rivers and canals.



### NOTE

The colors are random and do not indicate the quality of the spectra.

Upward looking peaks refer to upstream measurements, downward looking peak to downstream measurements.

+		<ul style="list-style-type: none"> <li>■ One distinct peak</li> <li>■ High intensity</li> <li>■ Smooth</li> <li>■ Negligible opposite direction</li> </ul>
+		<ul style="list-style-type: none"> <li>■ One distinct peak</li> <li>■ High intensity</li> <li>■ Smooth</li> <li>■ Negligible opposite direction</li> </ul>
+		<ul style="list-style-type: none"> <li>■ One distinct peak</li> <li>■ High intensity</li> <li>■ Little noise</li> <li>■ Negligible opposite direction</li> </ul>
+		<ul style="list-style-type: none"> <li>■ One distinct peak</li> <li>■ High intensity</li> <li>■ Little noise</li> <li>■ Negligible opposite direction</li> </ul>

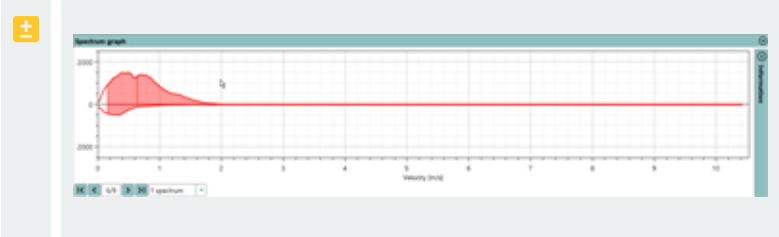

- Two little peaks
- Small opposite direction

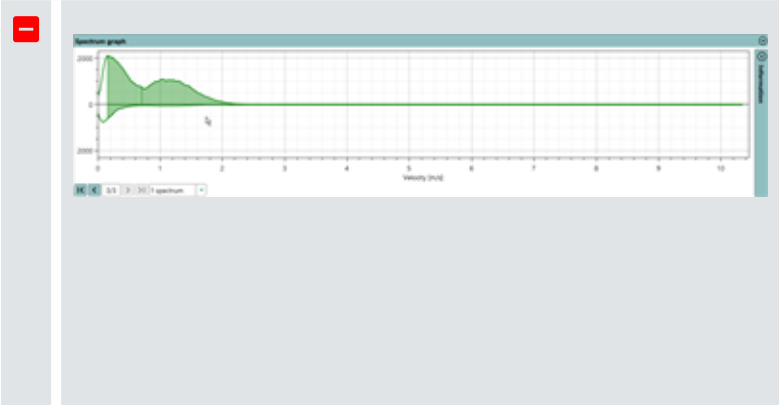

- Two peaks

**What you can do:**

- Change the sensor location
- Reduce or increase the vertical mounting position
- Align sensor parallel to flow direction
- Increase the measurement duration

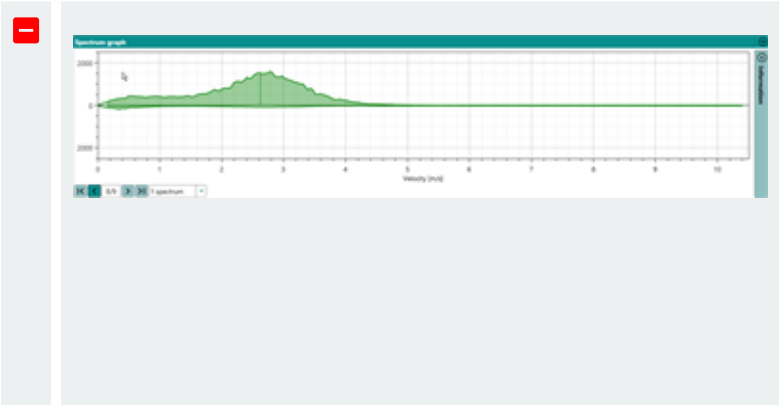

- Peak with a tail

**What you can do:**

- Reduce or increase the vertical mounting position
- Change the sensor location
- Increase the measurement duration
- Align sensor parallel to flow direction

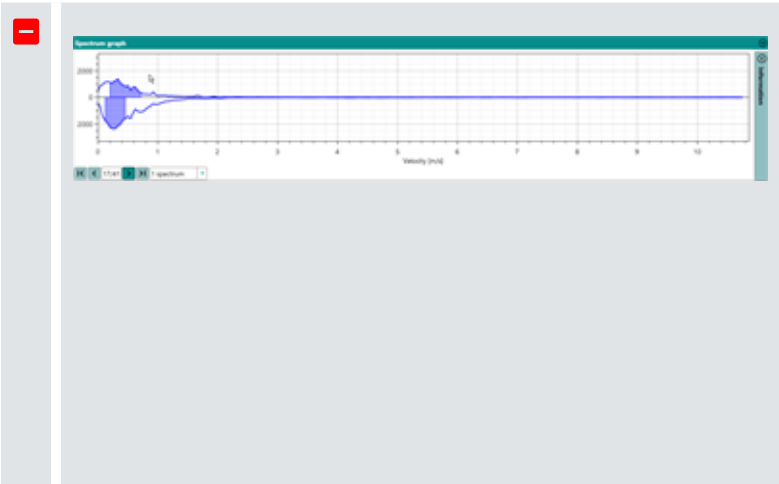

- High opposite direction content
- Noisy

**What you can do:**

- Align sensor parallel to flow direction
- Reduce or increase the vertical mounting position
- Increase the measurement duration
- Change the sensor location

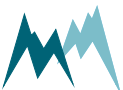

		<ul style="list-style-type: none"> <li>■ Extreme noise</li> </ul> <p><b>What you can do:</b></p> <ul style="list-style-type: none"> <li>■ Place a chain, rope or other item upstream into the water to create additional waves</li> <li>■ Increase the measurement duration</li> <li>■ Switch <b>Channel type</b> to closed or vice versa</li> </ul>
		<ul style="list-style-type: none"> <li>■ Very low velocity</li> <li>■ Very low intensity</li> </ul> <p><b>What you can do:</b></p> <ul style="list-style-type: none"> <li>■ Place a chain, rope or other item upstream into the water to create additional waves</li> <li>■ Increase the measurement duration</li> <li>■ Switch <b>Channel type</b> to closed or vice versa</li> </ul>
		<ul style="list-style-type: none"> <li>■ No peak</li> <li>■ Very low intensity</li> </ul> <p><b>What you can do:</b></p> <ul style="list-style-type: none"> <li>■ Place a chain, rope or other item upstream into the water to create additional waves</li> <li>■ Increase the measurement duration</li> <li>■ Switch <b>Channel type</b> to closed or vice versa</li> </ul>

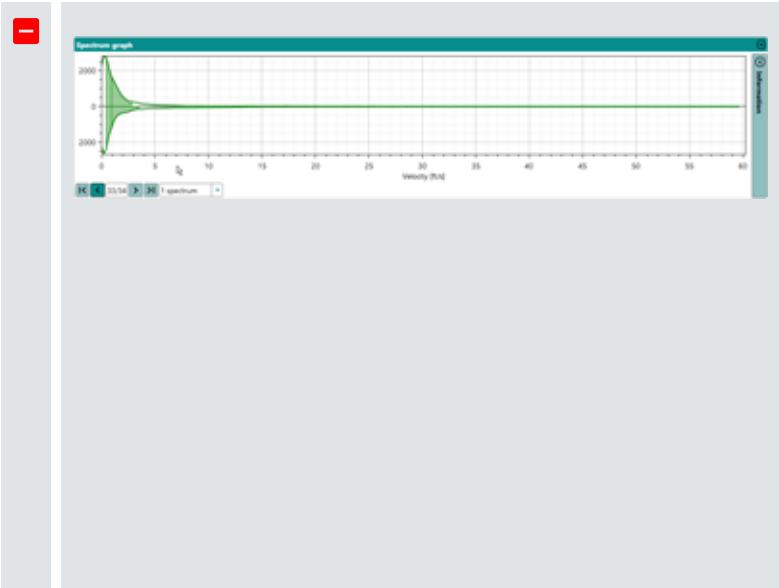

- Symmetric spectrum around zero at low velocities
- High intensity

**Reason**

- Glassy water surface with lake-like waves
- RQ-30+ measures vertical velocity

**What you can do:**

- Place a chain, rope or other item upstream into the water to create additional waves
- Change the sensor location

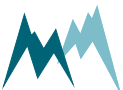

## Appendix C CRC-16 array

### CRC-16 array

```
1  crc16tab[] =
2  {
3  0x0000, 0x1021, 0x2042, 0x3063, 0x4084, 0x50A5, 0x60C6, 0x70E7,
4  0x8108, 0x9129, 0xA14A, 0xB16B, 0xC18C, 0xD1AD, 0xE1CE, 0xF1EF,
5  0x1231, 0x0210, 0x3273, 0x2252, 0x52B5, 0x4294, 0x72F7, 0x62D6,
6  0x9339, 0x8318, 0xB37B, 0xA35A, 0xD3BD, 0xC39C, 0xF3FF, 0xE3DE,
7  0x2462, 0x3443, 0x0420, 0x1401, 0x64E6, 0x74C7, 0x44A4, 0x5485,
8  0xA56A, 0xB54B, 0x8528, 0x9509, 0xE5EE, 0xF5CF, 0xC5AC, 0xD58D,
9  0x3653, 0x2672, 0x1611, 0x0630, 0x76D7, 0x66F6, 0x5695, 0x46B4,
10 0xB75B, 0xA77A, 0x9719, 0x8738, 0xF7DF, 0xE7FE, 0xD79D, 0xC7BC,
11 0x48C4, 0x58E5, 0x6886, 0x78A7, 0x0840, 0x1861, 0x2802, 0x3823,
12 0xC9CC, 0xD9ED, 0xE98E, 0xF9AF, 0x8948, 0x9969, 0xA90A, 0xB92B,
13 0x5AF5, 0x4AD4, 0x7AB7, 0x6A96, 0x1A71, 0x0A50, 0x3A33, 0x2A12,
14 0xDBFD, 0xCBDC, 0xFBBF, 0xEB9E, 0x9B79, 0x8B58, 0xBB3B, 0xAB1A,
15 0x6CA6, 0x7C87, 0x4CE4, 0x5CC5, 0x2C22, 0x3C03, 0x0C60, 0x1C41,
16 0xEDAE, 0xFD8F, 0xCDEC, 0xDDCD, 0xAD2A, 0xBD0B, 0x8D68, 0x9D49,
17 0x7E97, 0x6EB6, 0x5ED5, 0x4EF4, 0x3E13, 0x2E32, 0x1E51, 0x0E70,
18 0xFF9F, 0xEFBE, 0xDFDD, 0xCFFC, 0xBF1B, 0xAF3A, 0x9F59, 0x8F78,
19 0x9188, 0x81A9, 0xB1CA, 0xA1EB, 0xD10C, 0xC12D, 0xF14E, 0xE16F,
20 0x1080, 0x00A1, 0x30C2, 0x20E3, 0x5004, 0x4025, 0x7046, 0x6067,
21 0x83B9, 0x9398, 0xA3FB, 0xB3DA, 0xC33D, 0xD31C, 0xE37F, 0xF35E,
22 0x02B1, 0x1290, 0x22F3, 0x32D2, 0x4235, 0x5214, 0x6277, 0x7256,
23 0xB5EA, 0xA5CB, 0x95A8, 0x8589, 0xF56E, 0xE54F, 0xD52C, 0xC50D,
24 0x34E2, 0x24C3, 0x14A0, 0x0481, 0x7466, 0x6447, 0x5424, 0x4405,
25 0xA7DB, 0xB7FA, 0x8799, 0x97B8, 0xE75F, 0xF77E, 0xC71D, 0xD73C,
26 0x26D3, 0x36F2, 0x0691, 0x16B0, 0x6657, 0x7676, 0x4615, 0x5634,
27 0xD94C, 0xC96D, 0xF90E, 0xE92F, 0x99C8, 0x89E9, 0xB98A, 0xA9AB,
28 0x5844, 0x4865, 0x7806, 0x6827, 0x18C0, 0x08E1, 0x3882, 0x28A3,
29 0xCB7D, 0xDB5C, 0xEB3F, 0xFB1E, 0x8BF9, 0x9BD8, 0xABBB, 0xBB9A,
30 0x4A75, 0x5A54, 0x6A37, 0x7A16, 0x0AF1, 0x1AD0, 0x2AB3, 0x3A92,
31 0xFD2E, 0xED0F, 0xDD6C, 0xCD4D, 0xBDAA, 0xAD8B, 0x9DE8, 0x8DC9,
32 0x7C26, 0x6C07, 0x5C64, 0x4C45, 0x3CA2, 0x2C83, 0x1CE0, 0x0CC1,
33 0xEF1F, 0xFF3E, 0xCF5D, 0xDF7C, 0xAF9B, 0xBFBA, 0x8FD9, 0x9FF8,
34 0x6E17, 0x7E36, 0x4E55, 0x5E74, 0x2E93, 0x3EB2, 0x0ED1, 0x1EF0
35 }
```

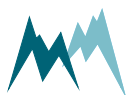

# Glossary

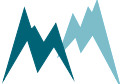

# Index

## M

Modbus 30, 81, 83, 113-115, 120-122, 156,  
158, 182, 191

## R

RS-485 19, 29-30, 41-42, 46, 64, 81, 94-96,  
103, 108, 114-115, 122, 134, 155, 157,  
162, 182, 190-191

## S

SDI-12 29-30, 41, 43, 81, 96, 107-112, 116,  
134, 147, 190

