

IDS-30cr

Icing measurement system

Manual

Setup version 2.04.03 (Firmware 1.14.00)

14.04.2025



Sommer Messtechnik

All rights reserved.

The Copyrights for this manual are exclusively owned by

Sommer Messtechnik
6842 Koblach
Austria

This manual or parts of it may only be copied or passed on to third parties with written permission of Sommer Messtechnik. This applies to printed as well as digital issues of this manual.



Sommer Messtechnik
Strassenhäuser 27
6842 Koblach
Austria
www.sommer.at
E office@sommer.at
T +43 5523 55989
F +43 5523 55989-19

Validity

This manual applies to the Icing measurement system with the setup version 2.04.03, including all its subversions.

Created: 31 Mar 2020

Last update: 14.04.2025



EU conformity



This product is in conformity with the following standards:

LVD	2014/35/EU	EN 62311:2008 EN 62368-1:2014
RoHS II	2011/65/EU	
RoHS III	2015/863/EU	

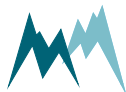

Safety information

Please read this manual carefully before installing or operating this equipment. Non-compliance with the instructions given in this manual can result in failure or damage of the equipment or may put people at risk by injuries through electrical or mechanic impact.

- Make sure that the personnel responsible for installation, configuration and maintenance is familiar with the applicable regulations and standards!
- Do not perform any installations in bad weather conditions, e.g. thunderstorms.
- Prior to installation of equipment inform the owner of the measurement site or the authority responsible for it. Upon completion, secure the installation from trespassers.
- Maintenance and repair must be performed by trained personnel or an engineer of Sommer Messtechnik. Only replacement parts supplied by Sommer Messtechnik should be used for repairs.
- Make sure that NO power is connected to the equipment during installation and wiring!
- Only use a power supply that complies with the power rating specified for this equipment!
- Keep equipment dry during wiring and maintenance!
- If applicable, it is recommended to use accessories of Sommer Messtechnik with this equipment.



ATTENTION

Do not submerge the cube or rod sensor in water! This may damage the internal electronics of the sensor or controller.

Disposal



After this device has reached the end of its lifetime, it must not be disposed of with household waste! Instead, dispose of the device by returning it to a designated collection point for the recycling of waste electrical and electronic equipment.

Feedback

Should you come across any error in this manual, or if you miss information to handle and operate the IDS-30cr we are pleased to receive your feedback to office@sommer.at.

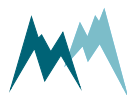

Content

- 1 What is the IDS-30cr? 12
- 2 Unpacking 13
- 3 Get started 14
 - 3.1 Connect the IDS-30cr to your PC 14
 - 3.2 Configure the IDS-30cr 15
 - 3.3 Acquire measurements 15
- 4 How the IDS-30cr works 17
 - 4.1 Sensors 17
 - 4.1.1 Cube 5 sensor 17
 - 4.1.2 Rod T 80 sensor 17
 - 4.2 Plausibility check 18
 - 4.3 Relay outputs 18
 - 4.4 Data interpretation 18
- 5 Components 21
 - 5.1 MAIN connector 21
- 6 Specifications 22
- 7 Installation 23
 - 7.1 Site selection 23
 - 7.2 Things to consider for installation 23
 - 7.2.1 Power supply 23
 - 7.2.2 Signal cables 24
 - 7.2.3 Lightning protection 24
 - 7.3 Required tools and equipment 24
 - 7.4 Mounting 24
 - 7.5 Wiring 25
 - 7.5.1 RS-485 wiring 25
 - 7.5.2 SDI-12 wiring 26
 - 7.6 Start-up 27
- 8 Operation 28
 - 8.1 Connect device to PC 28
- 9 Maintenance 29
- 10 Support software Commander 30

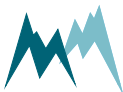

10.1	Software features	30
10.2	System requirements	30
10.3	Installation of Commander	30
10.4	Change authorization	35
10.5	Working with connections	36
10.5.1	Establish a connection with the Communication assistant	36
10.5.2	Establish a connection manually	36
10.5.3	Create a new connection	36
10.6	Working with stations	37
10.6.1	Create a station with the Communication assistant	37
10.6.2	Create a station manually	42
10.7	Working with measurements	43
10.7.1	Poll continuous measurements	43
10.7.2	Record measurements	43
10.8	Working with data	44
10.8.1	View live data	44
10.9	Working with spectra	45
10.9.1	Record spectrum	45
10.9.2	Read spectrum file	45
10.10	Working with setups	46
10.10.1	Download setup	46
10.10.2	Open a setup file	46
10.10.3	Edit setup	46
10.10.4	Upload new setup file	47
10.11	Update firmware	47
11	Configuration of the IDS-30cr	49
11.1	Software tools	49
11.2	Configuration with Commander support software	49
11.3	Configuration with a terminal program	52
11.4	General settings	53
11.4.1	Language/Sprache	53
11.4.2	Decimal character	53
11.4.3	Units and decimals	53
11.4.4	Output protocol (OP)	54
11.4.5	Information	54
11.5	Sensor setup	54
11.5.1	Cube 5, zero adjust	54
11.5.2	Rod 80, zero adjust	55

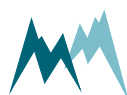

11.6	Heater configuration	55
11.6.1	Ice, maximum	55
11.6.2	Ice, minimum	55
11.6.3	Water, maximum	55
11.6.4	Water, minimum	55
11.6.5	Maximum heating time	56
11.6.6	Cool down duration	56
11.6.7	Meas. duration icing rate	56
11.7	Icing verification	56
11.7.1	Maximum temperature	56
11.7.2	Maximum water	56
11.8	Relay switching	56
11.8.1	Output value	57
11.8.2	Ice limit	57
11.8.3	Ice rate limit	57
12	Communication	58
12.1	Communication protocols	58
12.2	Data output	58
12.2.1	Main values	58
12.2.2	Special values	59
12.2.3	Analysis values	59
12.2.4	Exception values	61
12.3	RS-485	61
12.3.1	What is RS-485?	61
12.3.2	What can I do with it?	62
12.3.3	Configuration	62
12.3.4	Data output options	64
12.3.5	Sommer Bus Protocol (SBP)	64
12.3.6	Standard protocol	68
12.3.7	RS-485 commands	72
12.3.8	Sommer Messtechnik CRC-16	74
12.4	SDI-12	76
12.4.1	What is SDI-12?	76
12.4.2	What can I do with it?	76
12.4.3	Configuration	76
12.4.4	Data structure	76
12.4.5	SDI-12 commands	77
12.5	Modbus	81
12.5.1	What is Modbus?	81

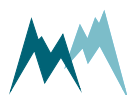

12.5.2	What can I do with it?	82
12.5.3	Wiring	82
12.5.4	Modbus configuration	82
12.5.5	Modbus commands and registers	88
12.5.6	Reactivate Sommer Bus Protocol	92
12.5.7	PLC integration	97
13	Parameter definitions	98
A	Relay A	98
A-A	Output value	98
A-B	Sensor choice	98
A-C	Turn off delay	98
A-D	Ice limit	99
A-E	Ice rate limit	99
A-F	Melting limit	99
A-G	Test output	99
B	Relay B	99
B-A	Output value	100
B-B	Sensor choice	100
B-C	Turn off delay	100
B-D	Ice limit	100
B-E	Ice rate limit	100
B-F	Melting limit	101
B-G	Test output	101
C	Sensor tests	101
C-A	Cube 5, test heating	101
C-B	Cube 5, test	101
C-C	Rod 80, test	101
D	Technics	102
D-A	SDI-12 address	102
D-B	Measurement Interval	102
D-C	Units and decimals	102
	D-C-A Temperature, unit	102
	D-C-B Temperature, decimals	103
D-D	SBP device addressing	103
	D-D-A Device number	103
	D-D-B System key	103
D-E	RS-485 (COM)	104
	D-E-A Output protocol	104
	D-E-A-A Output protocol (OP)	104

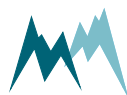

	D-E-A-B	Measurement output	105
	D-E-A-C	Information	105
	D-E-A-D	Wake-up sequence	105
	D-E-A-E	Prefix holdback	106
	D-E-A-F	MODBUS, set default	106
	D-E-A-G	MODBUS, device address	106
D-E-B	Port		106
	D-E-B-A	Baudrate	107
	D-E-B-B	Parity, stop bits	107
	D-E-B-C	Minimum response time	107
	D-E-B-D	Transmitter warm-up time	108
	D-E-B-E	Flow control	108
	D-E-B-F	Sending window	108
	D-E-B-G	Receiving window	108
D-F	Cube 5 sensor		109
	D-F-A	Icing verification	109
	D-F-A-A	Maximum temperature	109
	D-F-A-B	Maximum water	109
	D-F-A-C	Switch on delay	109
D-F-B	Limits and timer		110
	D-F-B-A	Min. sup. voltage for heating	110
	D-F-B-B	Ice, maximum	110
	D-F-B-C	Ice, minimum	110
	D-F-B-D	Water, maximum	110
	D-F-B-E	Water, minimum	111
	D-F-B-F	Ice rate, heating	111
	D-F-B-G	Ice rate, minimum	112
	D-F-B-H	Ice rate, holdtime	112
	D-F-B-I	Maximum heating time	113
	D-F-B-J	Subsequent heating, head	113
	D-F-B-K	Subsequent heating, shaft	113
	D-F-B-L	Cool down duration	113
	D-F-B-M	Duration frost suppression	114
	D-F-B-N	Meas. duration icing rate	114
D-F-C	Cube 5 temperature		114
	D-F-C-A	Temperature offset	115
	D-F-C-B	Adjust temperature	115
	D-F-C-C	Test temperature	115
D-F-D	Cube 5, test heating		115

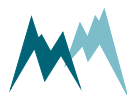

	D-F-E	Cube 5, zero adjust	115
	D-F-F	Cube 5, test	115
D-G		Rod 80 sensor	115
	D-G-B	Icing verification	116
		D-G-B-A Maximum temperature	116
		D-G-B-B Maximum water	116
		D-G-B-C Switch on delay	116
	D-G-C	Rod 80 temperature	116
		D-G-C-A Temperature offset	117
		D-G-C-B Adjust temperature	117
		D-G-C-C Test temperature	117
	D-G-D	Rod 80, zero adjust	117
	D-G-E	Rod 80, test	117
D-H		Advanced settings	117
	D-H-A	Sleep mode	117
	D-H-B	SDI12 'M'-response	118
	D-H-C	Functional switch monitoring	118
	D-H-D	Sommer ID	119
D-I		Measurement table	119
E		Region format	120
	E-A	Language/Sprache	120
	E-B	Decimal character	120
F		Special functions	120
	F-A	Relay, reset counters	121
	F-B	Relay, simulate outputs	121
	F-C	Device status	121
	F-D	View setup	121
	F-E	Set factory default	121
	F-F	Temp. load factory default	121
	F-G	Relaunch program	122
Appendix A		Measurement phases	123
	A.1	Sensor status	123
	A.2	Icing verification	123
Appendix B		Troubleshooting	125
	B.1	Devices	125
		B.1.1 The IDS-30cr is not responding or returns unreadable characters	125
		B.1.2 The IDS-30cr reboots repeatedly	127
	B.2	Measurement data	127
		B.2.1 Measurement data are not updated	127



B.2.2	Heating current returns -0.02 A or 99999997.	127
B.3	Firmware & software	128
B.3.1	Commander loads wrong setup	128
B.3.2	Firmware update via RS-485 is aborted	128
B.4	RS-485	128
B.4.1	Configuration via terminal shows unexpected behavior	128
B.5	SDI-12	129
B.5.1	The IDS-30cr is not detected by a SDI-12 master device	129
B.5.2	Data logger receives no SDI-12 data	129
B.6	Modbus	129
B.6.1	Modbus function 04 returns obscure measurement values	129
Appendix C	CRC-16 array	131

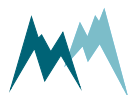

1 What is the IDS-30cr?

During the winter season in higher latitude regions a lot of our infrastructure is affected by icing. Power generation by wind turbines may be impaired under icy condition, leading to reduced power output and longer maintenance times. Reliable ice detection systems help reduce associated costs and down times.

The IDS-30crrc provides a sensor-combination that can measure ice layers from 0.2 mm to 40 mm. By measuring the complex impedance in the vicinity of the sensor, the IDS-30crrc is able to distinguish between water and ice and capable to record ice accretion rates and total ice load.

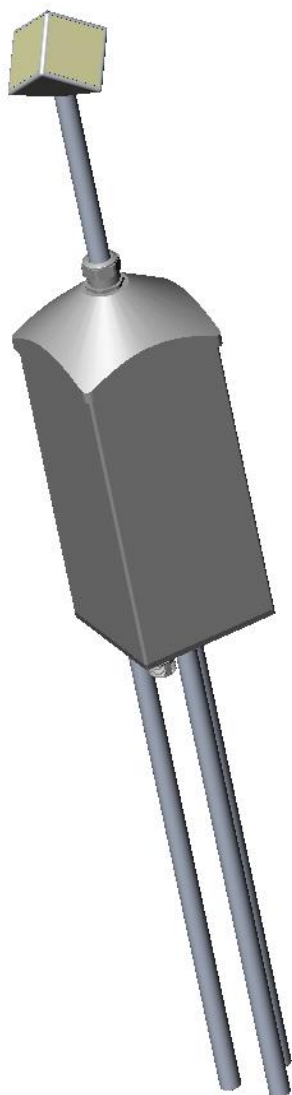

Figure 1 IDS-30cr

2 Unpacking

When unpacking your IDS-30cr sensor box please make sure that the following items are present:

Qty	Name
1	IDS-30cr in the required version
1	Mounting kit
1	Sensor cable
1	Manual and Commander Software on USB stick

In case of missing or damaged items please contact your Sommer Messtechnik sales partner.

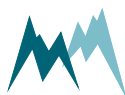

3 Get started

Follow the steps described below to set the basic configurations and to acquire the first measurement results.



NOTE Perform the first start-up in your lab or office before installing the equipment in the field!

3.1 Connect the IDS-30cr to your PC

1. Install the Commander support software (see [Installation of Commander](#)).
2. Connect the yellow and gray wires of the sensor cable to the RS-485 to USB converter cable and plug it into your PC as illustrated in the figure below.
3. Connect a 9...28 VDC power supply to the IDS-30cr as shown in the figure below.
4. Click on [Communication assistant](#) on the right-hand side of the Commander window and follow the instructions.
 - a. As [Type of connection](#) select [Serial connection](#)
 - b. As [Device type](#) select [Sensor \(9600 Bd\)](#)
 - c. Select [New connection](#) and select the COM port

During this procedure the communication assistant will search for connected devices. Upon successful completion, the new connection is added to the connections list (tab [Connections \(F8\)](#)).

5. In the [Communication](#) section at the right-hand side of the Commander window select [Mode Connection](#) and the previously created connection from the drop-down list.
6. Click [Connect](#) to establish a connection with the IDS-30cr. If the connection was successful a green icon is displayed at the top-right corner of the Commander window.
7. Select the tab [Parameters \(F2\)](#) and click [Download parameters from device](#) on the left side of the Commander window. The complete parameter list is transferred from the sensor to your PC and displayed in the [Parameter](#) window.

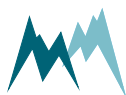

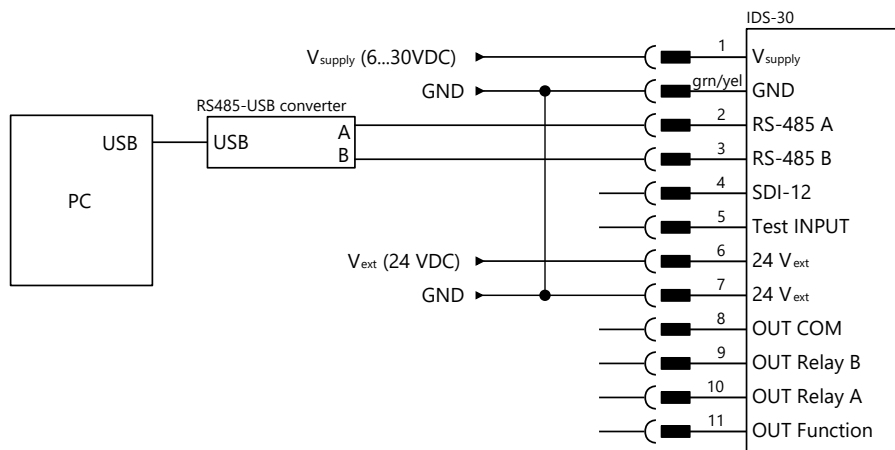

3.2 Configure the IDS-30cr

1. Select language, decimal character, units and decimal places (see [General settings](#))
2. Define scope and structure of the data output (see [General settings](#))
3. Set the zero-reading of the sensor (see [Sensor setup](#))
4. Set the limits at which the relays switch (see [Relay switching](#))
5. Send any modifications to the IDS-30cr by clicking [Upload modified parameters to device](#).

3.3 Acquire measurements

1. Establish a connection to your device as described in [Working with connections](#).
2. Download the setup of your device as described in [Download setup](#).
3. Select the [Measurement \(F3\)](#) tab.
4. In the [Commands](#) section click [Start polling measurement](#).
5. Select the option [Polling with measurements](#). Now, the Commander will trigger measurements of the IDS-30cr without any delays between measurements. The results are displayed [Measurement values](#) and plotted in the [Measurement data graph](#).

6. To finish polling mode click **Stop polling**.

The screenshot shows the Commander 2.0.3.9 software interface. The 'Measurement values' table is as follows:

ID	Name	Value	Unit
0	Self-check	0	
1	Level	49	mm
2	Velocity	1.003	m/s
3	Quality (SNR)	67.25	
4	Flow	5.143	m ³ /h
5	Flow sum		m ³
6	Learned velocity	1.003	m/s
7	Learned flow	5.143	m ³ /h

The 'Measurement data graph' shows a red line representing 'Flow [m³/h]' over time. The y-axis ranges from 0 to 5. The graph shows a steady increase in flow, followed by a sharp dip and then a recovery to a higher level. A red callout box points to the last data point with the text 'Last measurement'. Another red callout box points to the 'Start and stop polling' buttons in the 'Polling commands' section.



TIP

To test the response of a cube or rod sensor, place a wet piece of paper (e.g. a wet Post-it® note) onto one of the sensor surfaces. This will give a water reading >0 mm. Note that this test will not produce exact or reproducible results!



ATTENTION

Do not submerge the cube or rod sensor in water! This may damage the internal electronics of the sensor or controller.

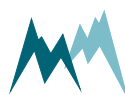

4 How the IDS-30cr works

The IDS-30cr ice sensor makes use of the different physical characteristics of air, water and ice at varying frequencies of an applied voltage. As illustrated in Figure 2 a single ice-sensor consists of two conductive paths which generate an electric field between them when powered. This electric field is different for air, water and ice. By measuring the resulting complex impedance at different frequencies the volume content of ice, water and air can be detected.

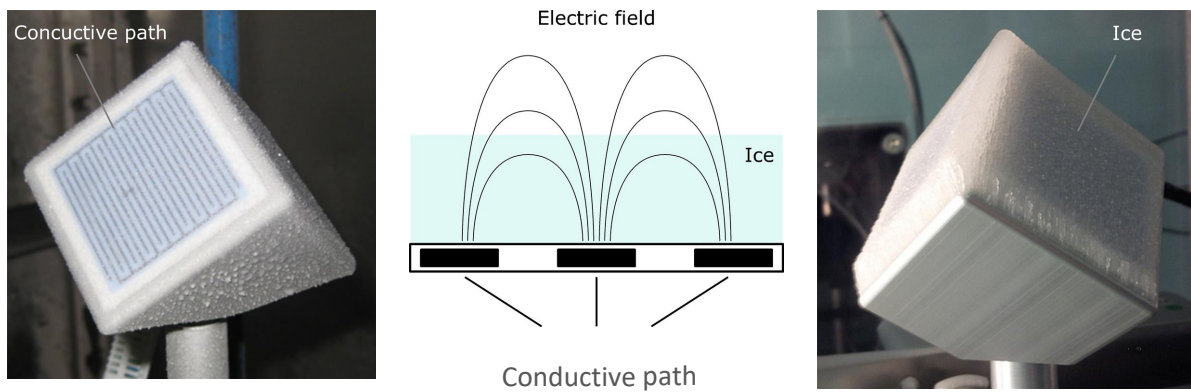

Figure 2 Principle of ice detection

4.1 Sensors

The IDS-30cr is equipped with a Cube 5 and a Rod T 80 sensor.

4.1.1 Cube 5 sensor

The Cube 5 sensor contains three sensor plates arranged in an angle of 120° to each other. The sensor plates can detect water, freezing rain and ice accretion from 0.2 to 2 mm.

The sensor head contains a Pt1000 sensor to monitor the surface temperature of the device. Sensor head and shaft can be heated separately with a 24 VDC power supply.

4.1.2 Rod T 80 sensor

The Rod T 80 sensor consists of three metal rods arranged in a triangle. The sensor can detect water, freezing rain and ice accretion from 1 to 40 mm.

The sensor head contains a Pt1000 sensor to monitor the surface temperature of the device. The sensor does not contain a heating option.

4.2 Plausibility check

Formation and accretion of ice on a surface depends on specific environmental conditions determined by air temperature, humidity and surface temperature.

The IDS-30cr uses the sensor surface temperature to verify any detected icing. Only if the surface temperature is below the freezing point the detected icing is confirmed as actual icing.

4.3 Relay outputs

The IDS-30cr provides two relay outputs to record the occurrence of icing events or to trigger an action upon ice detection. Both relays can be configured to switch at a specified ice or water layer thickness or icing rate. By doing so, different switching combinations can be selected:

- relay A and B respond to limit values of one sensor, e.g. ice layer thickness and icing rate
- relay A responds to a limit value of sensor 1, e.g. presence of water, and relay B to a limit value of sensor 2, e.g. icing rate
- one relay responds to a limit value of one sensor, e.g. icing rate, and the other is turned off

The IDS-30cr contains an additional relay that responds to the state of the device, i.e. switches if the IDS-30cr detects an error. The relay output can be configured to either close on proper functioning of the device or if the device detects an error.

4.4 Data interpretation

Ice forms at certain air and surface temperatures under high humidity levels. In many applications the information of instantaneous icing on a surface is required. In others, the duration and intensity of an icing event is of interest. In the following examples the interaction between atmospheric conditions and the occurrence of icing is illustrated.

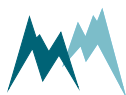

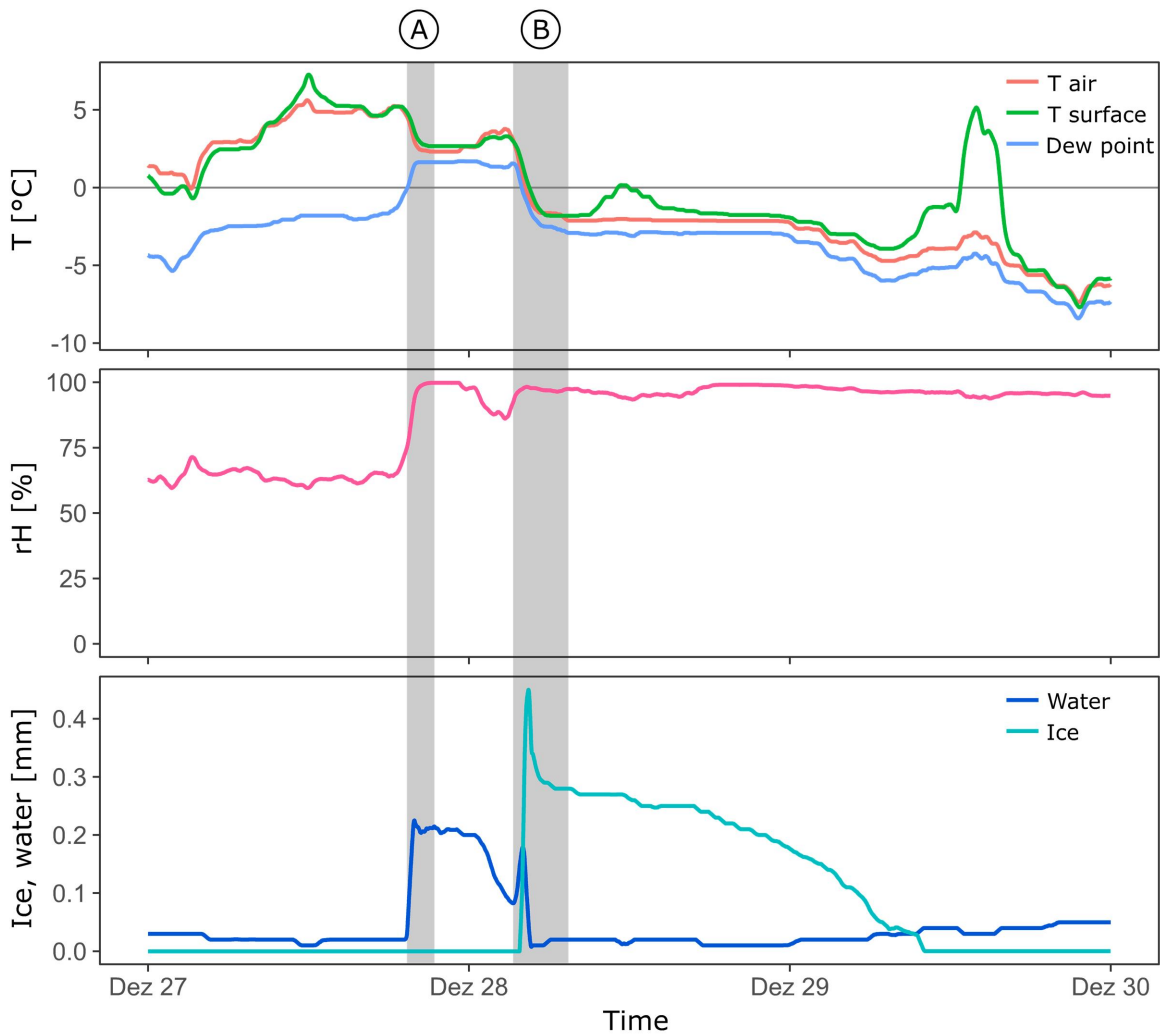
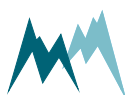

Figure 3 Dew and ice on a Cube 5 sensor

In Figure 3 the formation of water and ice on a Cube 5 sensor is shown. In period A the air and surface temperature of the sensor drop and closely reach the dew point, thus increasing the relative humidity. As a consequence water condenses on the sensor surface as illustrated in the lower plot.

During the early morning hours the air and surface temperature further drop below freezing. This temperature drop first leads to more water condensation and is then followed by a sharp rise in ice formation as the water freezes. Shortly after, the sun rises and transforms the thin ice layer on the sensor through irradiation. This is visible by a quick drop of the ice thickness. During the day more ice sublimates despite below-zero temperatures.



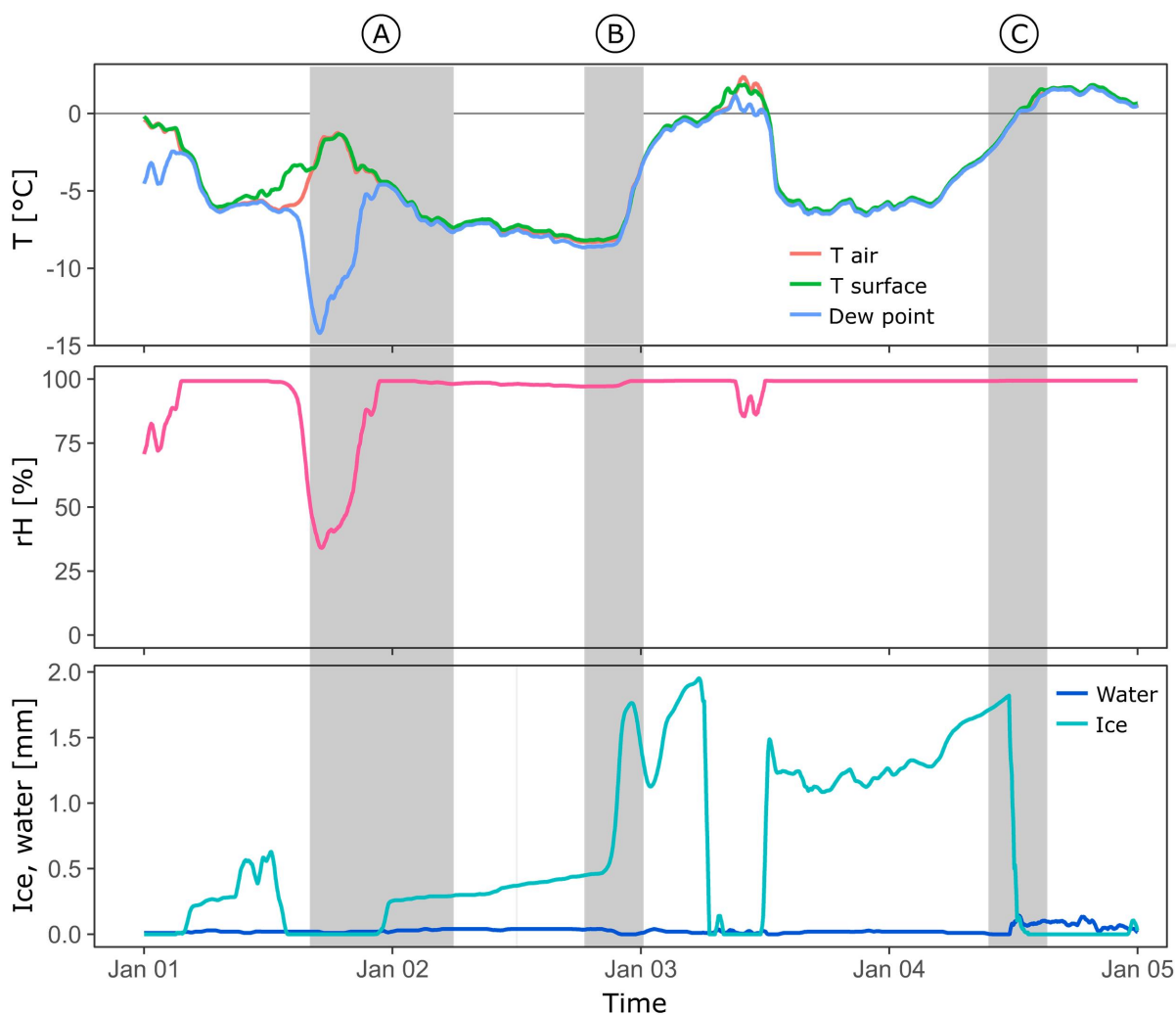

Figure 4 Icing of a Cube 5 sensor

In Figure 4 several icing events of a Cube 5 sensor are illustrated. During period A air and sensor surface temperature are below zero. However, due to relatively dry air no ice is formed on the sensor. Later on, as the temperature drops again, the humidity approaches saturation. As soon as the frost point is reached, ice starts to accrete on the sensor surface and keeps doing so with further falling temperatures.

During period B the temperature reaches a minimum and then rises within a few hours by more than 5°C. Consequently, the ice layer on the sensor grows considerably faster.

In period C the temperature rises from below zero to positive temperatures, keeping its water saturation. Once the temperature passes 0°C the ice on the sensor melts rapidly, which is marked by a sharp drop in ice layer thickness and a slight increase of water on the surface.

5 Components

5.1 MAIN connector

MAIN (12 Pins)	Pin/Wire	Function	Description
Power supply	1	Vsupply	10...30 V
	12	GND	yellow-green
RS-485 interface	2	RS485 A	1 x RS-485 (1200...115200 Baud) ASCII – Protokoll Modbus
	3	RS485 B	
SDI-12 interface	4	SDI12	1 x SDI-12 (1200 Baud)
Test-INPUT (Simulation)	5	Test	Low Level: 0...0,6 V High Level: 2...30 V
Heating	6	+24V _{ext}	DC heating power supply
	7	-24V _{ext}	
Relay OUTPUT	8	OUT COM	potential-free, max. 0.8A
	9	OUT Relay B	
	10	OUT Relay A	
	11	OUT function	



ATTENTION The relay outputs are referenced to GND on pin 12.

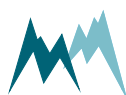

6 Specifications

IDS-sensors		
Sensor type	Cube sensor 5	Rod sensor 80
Measuring range ice thickness	0.2...2 mm	1...40 mm

IDS-controller	
Power supply	Sensors 10...28 VDC Heating 24 VDC integrated overvoltage protection
Power consumption	Active measurement 50 mA at 12 VDC Heating max. 5A at 24 VDC
Output	RS-485 (Modbus) SDI-12 3x relay output, max. 0.8 A each
Operating temperature	-40...60 °C
Protection rating	IP 66
Lightning protection	Integrated Lightning Protection against indirect Lightning; discharge capacity 0,6 kW Ppp
Size L x W x H	1055 x 133 x 133 mm
Weight	3.5 kg

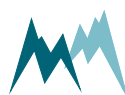

7 Installation

7.1 Site selection

The IDS-30cr may be installed as a stand-alone system or mounted to facilities such as wind turbines, utility poles or antennas. To gain icing data that describe the icing on the monitored facility as accurate as possible the IDS-30cr has to be installed at a representative position. This means that the ice-sensors should face the same environmental conditions as the monitored facility. Especially, the ice-sensors should not be mounted in the lee of an installation. It is also very important that the ice-sensors are influenced as little as possible by any installation or structure. Make sure that the sensors are not installed too close to your monitored facility.

The sensors and controller of the IDS-30cr have very low power consumption and can be operated with an autonomous power supply, e.g. solar generator. However, if the IDS-30cr is operated with sensor heating (up to 5 A at 24 VDC) your measurement site needs to have access to mains power.

The IDS-30cr must not be installed where passers-by could be hit by falling ice. If required, close off the measurement site and/or indicate the risk.

7.2 Things to consider for installation

7.2.1 Power supply

The IDS-30cr consumes 50 mA @ 12 V during active measurements. Between measurements the IDS-30cr automatically switches into standby-mode.

The Cube 5 sensor of the IDS-30cr is heated if a defined ice-layer thickness is exceeded. This heating requires up to 5A @ 24V and can be provided by a 24 VDC power supply. The Rod T 80 sensor has no heating.



ATTENTION

Make sure that the sensor and the heater power supplies share the same ground! Different grounds can lead to erroneous measurement values.

The heating current is not controlled, i.e., the higher the heater supply voltage the higher the heating power!

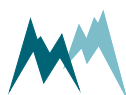

7.2.2 Signal cables

7.2.2.1 Maximum cable length

Please consider the maximum cable lengths for the applied transmission protocol:

Cross section	Max. cable length
12 × 0,25 mm ²	~60 m (depending on wire cross section and number of sensors)
12 × 0,75 mm ²	~300 m

Table 1 Maximum cable lengths



NOTE Cable lengths longer than 60 m require a heavier gauge wire if the power supply drops below 11 V.

7.2.3 Lightning protection

If the underground at the measurement site permits sufficient current dissipation it is strongly recommended to equip the sensor support or mast with properly dimensioned lightning protection. Consult an expert for advice.

The IDS-30cr is protected against overvoltage. If a data logger is mounted to the mast, its ground lug must be properly connected to earth ground.

7.3 Required tools and equipment

Prepare the following tools and equipment to install the IDS-30cr:

Qty	Tool
1	Flat spanner 13 mm
1	Wire cutter

7.4 Mounting

The IDS-30cr can be mounted in three different ways, depending on the available rails:

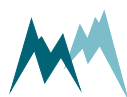

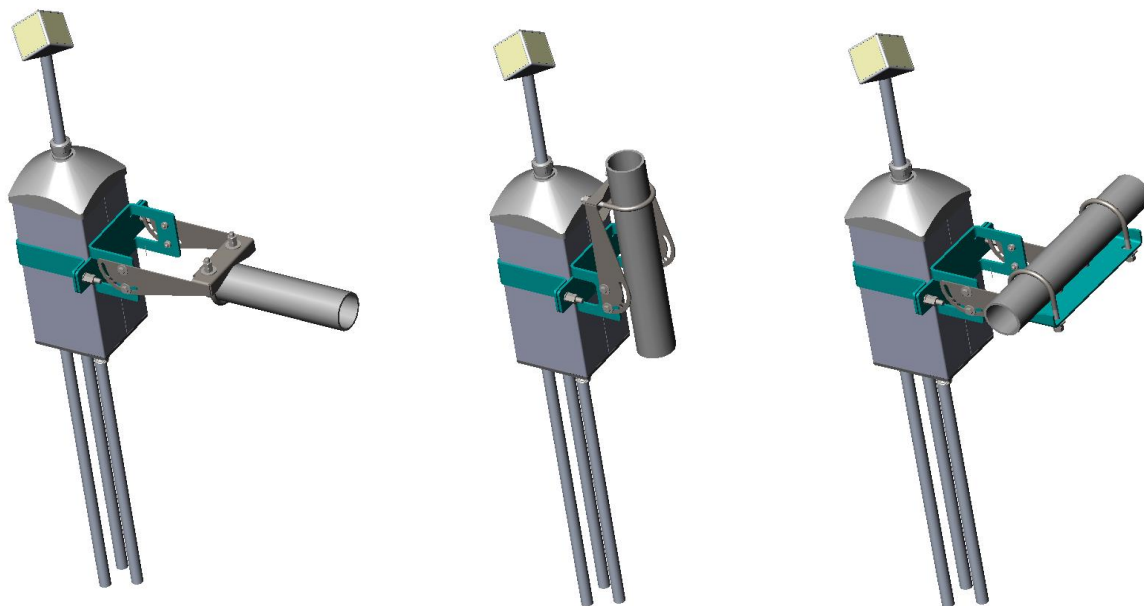

After attaching the bracket to the body of the IDS-30cr, mount the unit to a tube of max. \varnothing 60 mm with the provided U-bolt(s).



ATTENTION

For correct detection of icing the IDS-30cr must be installed upright with the rods pointing downwards.

Fasten counter-nuts to the bolts of the brackets! Vibrations of the wind turbine may otherwise loosen the IDS-30cr.

7.5 Wiring



ATTENTION

Make sure that the sensor and the heater power supplies share the same ground! Different grounds can lead to erroneous measurement values.

The heating current is not controlled, i.e., the higher the heater supply voltage the higher the heating power!

7.5.1 RS-485 wiring

Connect the IDS-30cr to a data logger or RS-485 network according to the figure below.

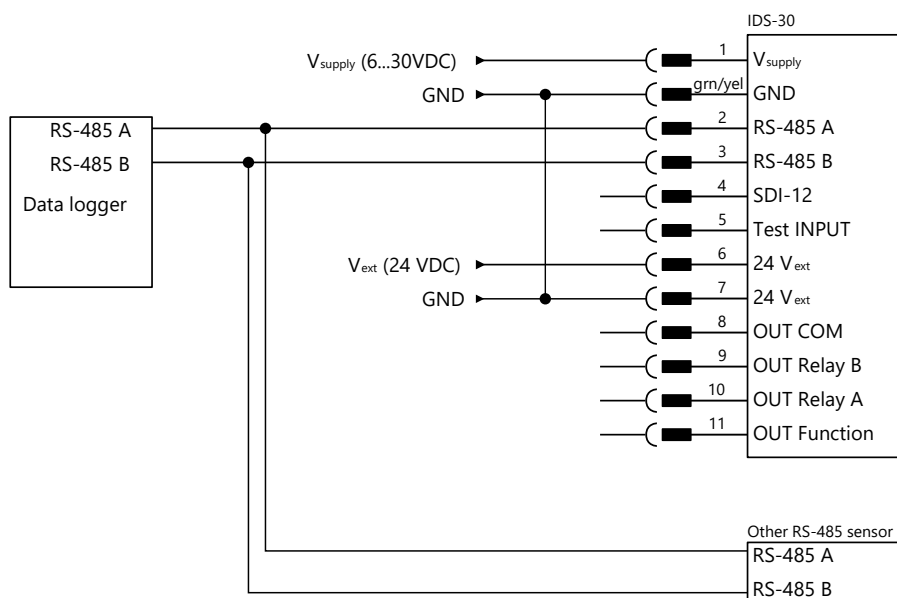

ATTENTION

If multiple Sommer Messtechnik devices are connected to a data logger over the same bus, all devices must share the same ground (GND)!

7.5.2 SDI-12 wiring

Connect the IDS-30cr to a data logger by SDI-12 according to the figure below.

SDI-12 uses a shared bus with a ground wire, a data wire (indicated as SDI-12) and an optional +12 V wire.



NOTE The connection with the 12 V power supply is optional and depends on the connected SDI-12 master device (typically a data logger).

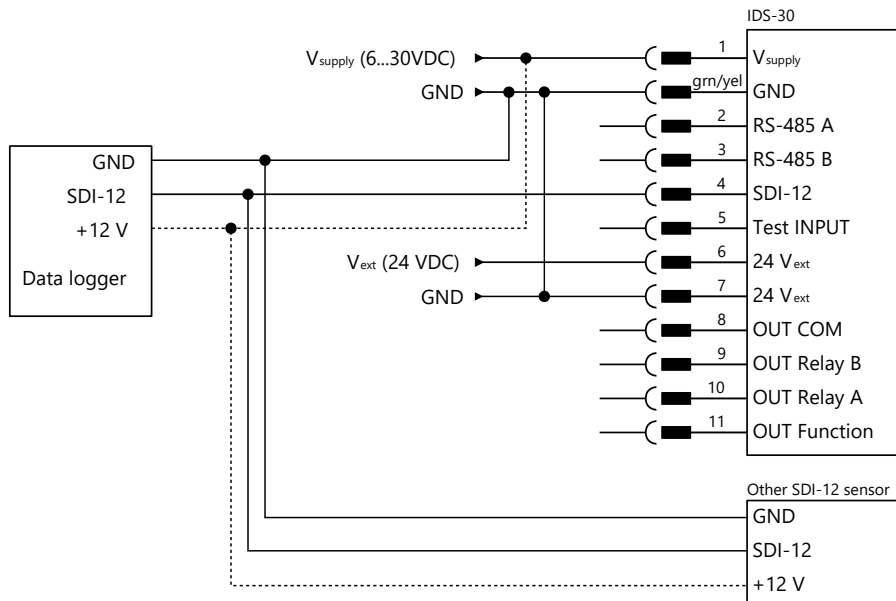
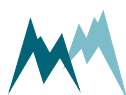

Figure 5 Wiring of the IDS-30cr with a data logger via SDI-12

7.6 Start-up

After successful testing, verify that the measurement data are recorded by your data acquisition system and check the data transmission to the remote server if applicable.



8 Operation

8.1 Connect device to PC

1. Install the Commander support software (see [Installation of Commander](#)).
2. Connect the yellow and gray wires of the sensor cable to the RS-485 to USB converter cable and plug it into your PC as illustrated in the figure below.
3. Connect a 9...28 VDC power supply to the IDS-30cr as shown in the figure below.
4. Click on [Communication assistant](#) on the right-hand side of the Commander window and follow the instructions.
 - a. As [Type of connection](#) select *Serial connection*
 - b. As [Device type](#) select *Sensor (9600 Bd)*
 - c. Select [New connection](#) and select the COM port

During this procedure the communication assistant will search for connected devices. Upon successful completion, the new connection is added to the connections list (tab [Connections \(F8\)](#)).

5. In the [Communication](#) section at the right-hand side of the Commander window select Mode [Connection](#) and the previously created connection from the drop-down list.
6. Click [Connect](#) to establish a connection with the IDS-30cr. If the connection was successful a green icon is displayed at the top-right corner of the Commander window.
7. Select the tab [Parameters \(F2\)](#) and click [Download parameters from device](#) on the left side of the Commander window. The complete parameter list is transferred from the sensor to your PC and displayed in the [Parameter](#) window.

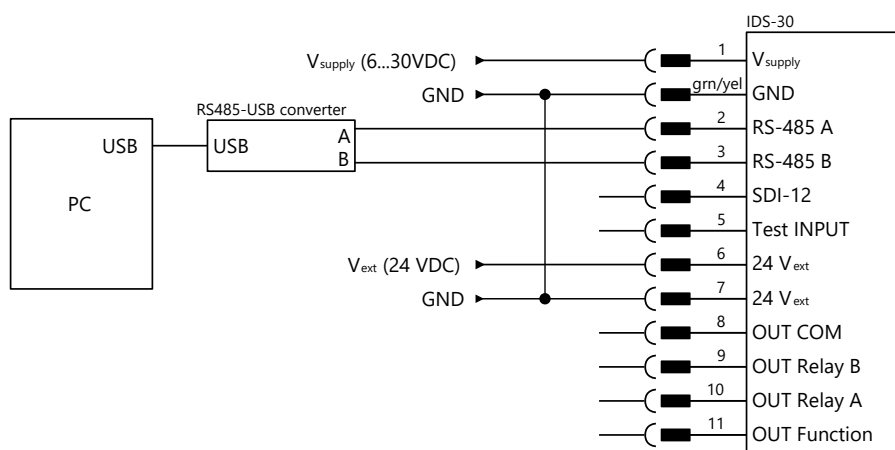

To activate the communication between your device and the Commander software follow the steps described in [Working with connections](#).

9 Maintenance

The IDS-30cr generally does not require any special maintenance. However, the ice-monitoring system should be inspected regularly for any damage or soiling on the Cube 5 sensor. If required, the sensor head and rods can be cleaned with water.

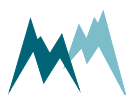

10 Support software Commander

10.1 Software features

The Commander is a multipurpose software tool to configure and operate any Sommer Messtechnik device. It offers the following functions:

- Communication with Sommer Messtechnik sensors and data loggers via serial connection, modem, socket, IP-call and Bluetooth®
- Management of connections and stations
- Configurations of sensors and data loggers
- Live data monitoring and storage
- Data management including download from data loggers and transmission to MDS (Measurement Data server)
- Terminal window to check data transfer and to access device settings directly

10.2 System requirements

The Commander software supports 32- and 64-bit versions of Windows 7 SP1, Windows 8, Windows 8.1, Windows 10 and Windows 11.

For correct operation Microsoft® .NET Framework 4.5 or later must be installed.

10.3 Installation of Commander

Follow the steps below to install the Commander software:

1. Plug the USB stick shipped with the device into your PC.
2. Double-click the [commander.msi](#) installer file on the USB drive.

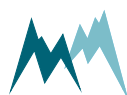

3. Click **Next** on the pop-up window



4. Read the instructions and click **Next**

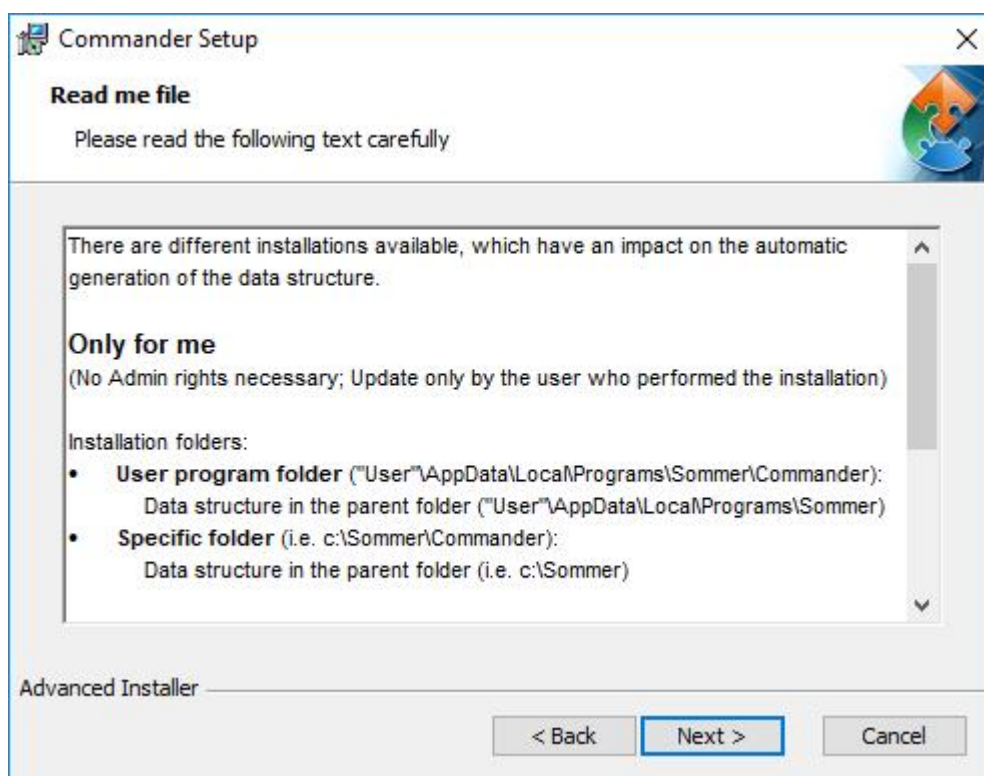

5. Select the installation type and click **Next**

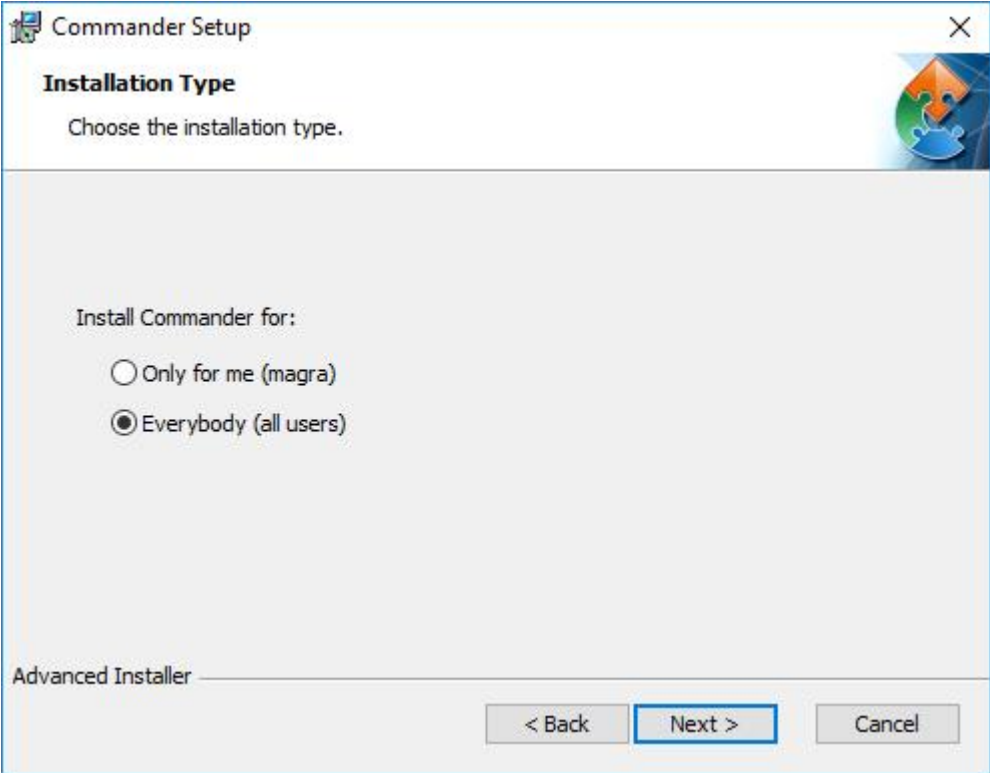

NOTE

Two installation types are available. Depending on the selection, the access rights and the folder structure differ:

Only for me

No admin rights are required. Updates are only available to the user who installed the software.

Installation folders:

- User program folder:
Users\User\AppData\Local\Programs\Sommer\Commander
Data structure:
Users\User\AppData\Local\Programs\Sommer
- Specific folder (default):
C:\Sommer\Commander
Data structure (default):
C:\Sommer

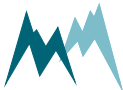



Everybody

Admin rights are required. Updates may only be performed by system administrators.

Installation folders:

- Standard program folder:
Program Files (x86)\Sommer\Commander
Data structure:
Users\Public\Public documents\Sommer
- Specific folder (default):
C:\Sommer\Commander
Data structure (default):
C:\Sommer

6. Select the installation directory and click **Next**

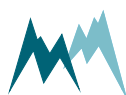
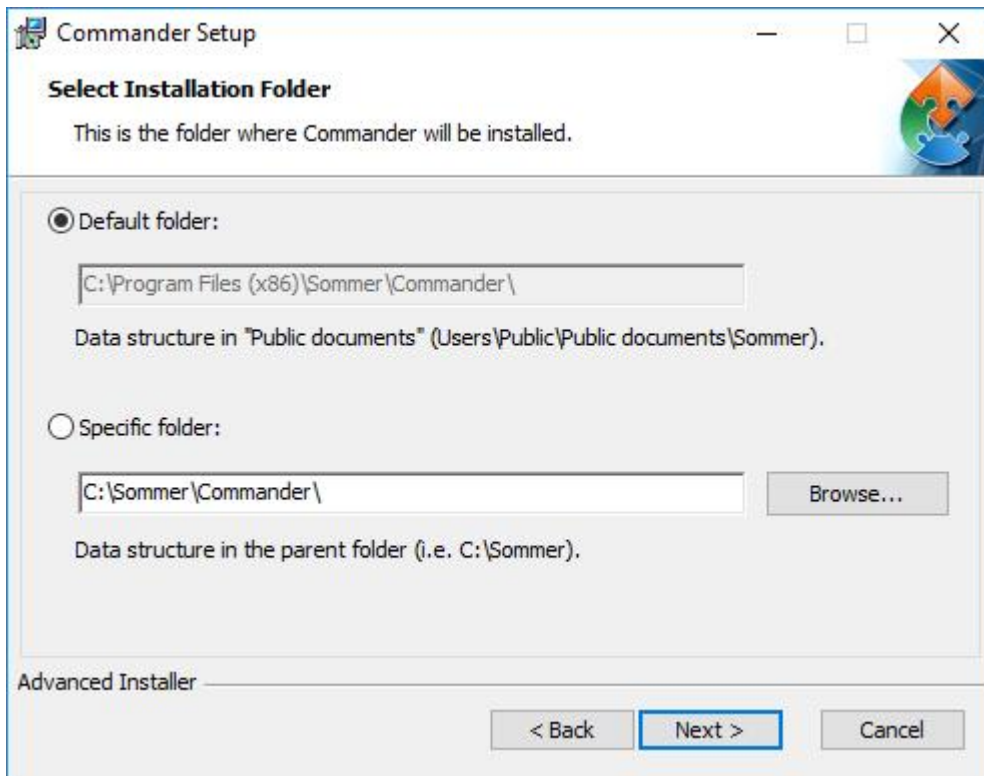

7. Select the features to be installed and click **Next**

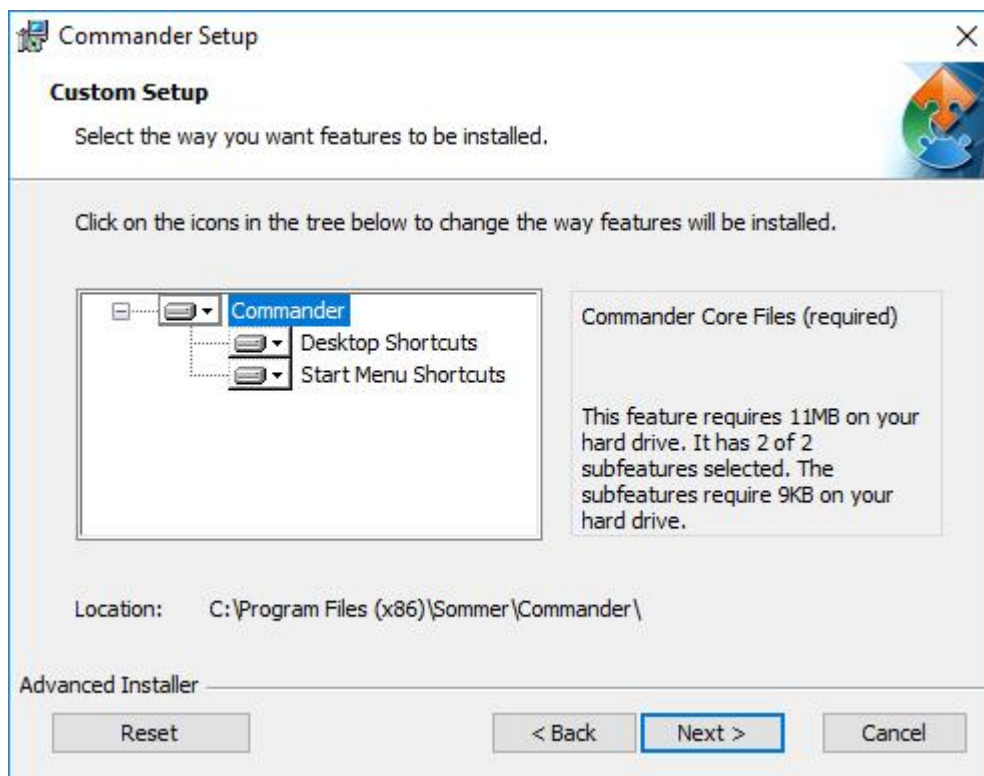

8. Click **Install** to start the installation.

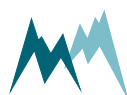
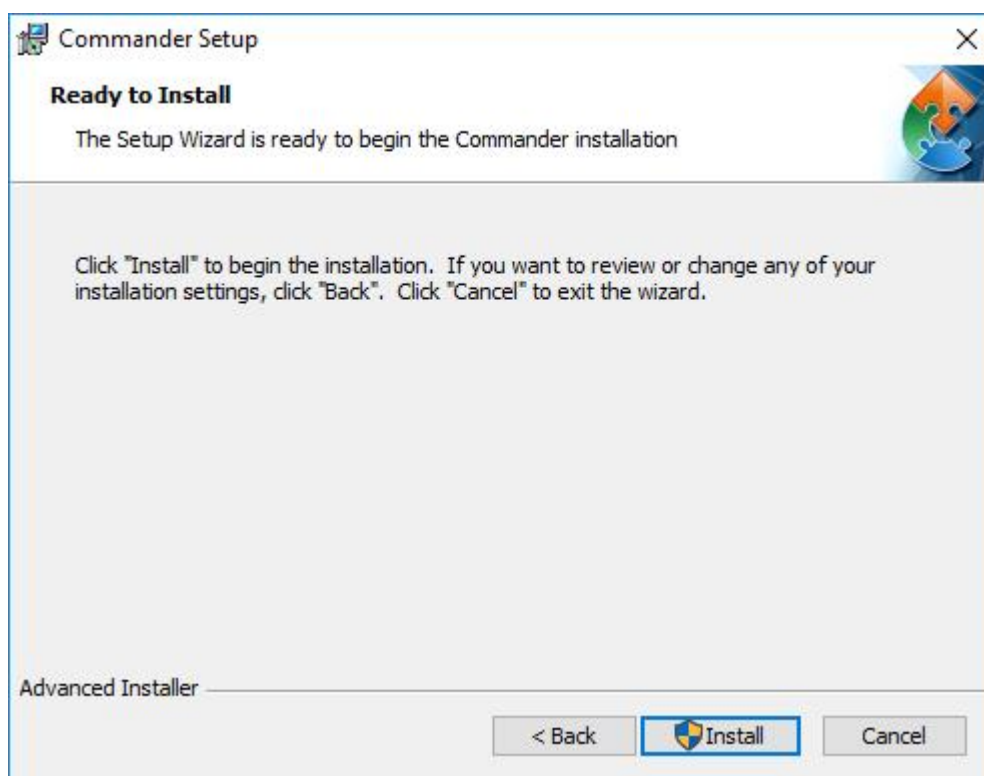

- Click **Finish** to complete the installation.

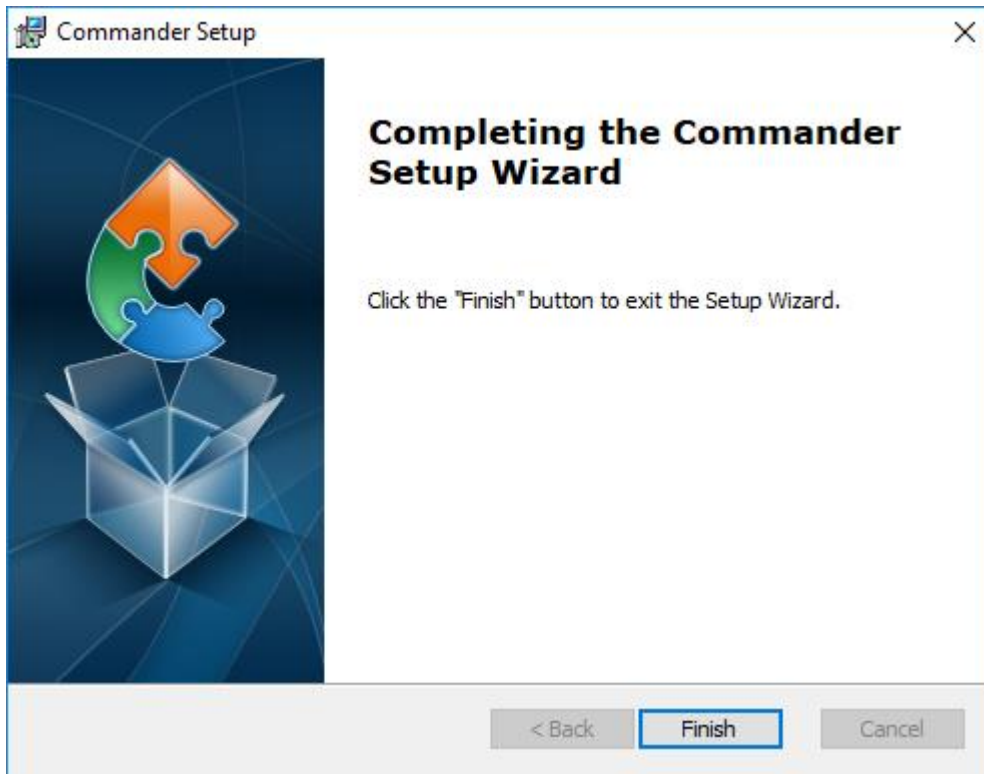

10.4 Change authorization

To prevent unintended changes of parameters in the **Technics** menu authorization is generally set to **Normal**. Parameter modifications in **Technics** are enabled by switching the authorization level to **Expert** as described below:

- On the upper tab bar click on **Options** and select **Common**.
- In the Options window select authorization **Expert** and click **OK**.

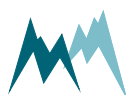
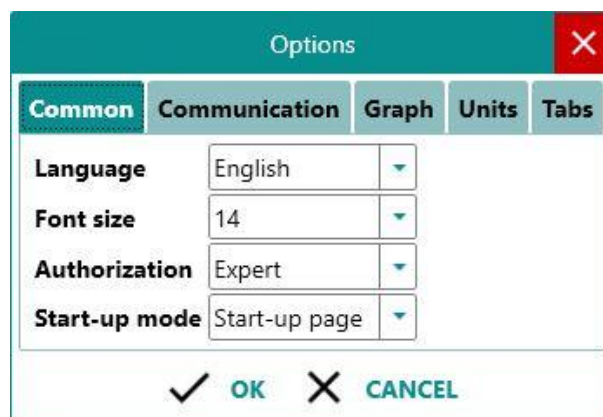

10.5 Working with connections

10.5.1 Establish a connection with the Communication assistant

1. Install the Commander support software as described in [Installation of Commander](#).
2. Connect the device to your PC.
3. Start the Commander software on your PC.
4. Click on **Communication assistant** on the right-hand side of the Commander window and follow the instructions. During this procedure the communication assistant will search for connected devices. Upon successful completion, the new connection is added to the connections list (tab **Connections (F8)**). See also pictures steps 1 to 8 in [Create a station with the Communication assistant](#).
5. In the **Communication** section at the right-hand side of the Commander window select **Mode Connection** and the previously created connection from the drop-down list.
6. Click **Connect** to establish a connection with the IDS-30cr. If the connection was successful a green icon is displayed at the top-right corner of the Commander window.

To view the settings of the connected device or to read the current measurements, follow the steps described in [Download setup](#) and [Record measurements](#).

10.5.2 Establish a connection manually

1. Install the Commander support software as described in [Installation of Commander](#).
2. Connect the device to your PC.
3. Start the Commander software on your PC.
4. Select the required connection in the **Connections** list of the **Connections (F8)** tab and click **Connect**. If the connection was successful a green icon is displayed at the top-right corner of the Commander window.

If you don't have the required connection available in the **Connections** list, create a new connection as described in [Create a new connection](#).

To view the settings of the connected device or to read the current measurements, follow the steps described in [Download setup](#) and [Record measurements](#).

10.5.3 Create a new connection

1. Select the **Connections (F8)** tab in the Commander. If the tab is not shown, select it with pressing **F8**.
2. Click **New connection**.

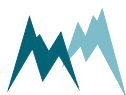

3. In the section **Connection settings** enter a name of the new connection, e.g. *Serial-com1-9600*, and the connection type, e.g. *Serial connection*.
4. Enter the required information for the selected connection type.
If your IDS-30cr is wired to your PC with a RS-485 to USB converter cable, select the port where the device is connected and select a Baud rate of 9800.

10.6 Working with stations

10.6.1 Create a station with the Communication assistant

In order to manage several data loggers, to connect to a data logger via IP-call and to download data, stations can be created in the Commander software. To view a list of all stations select the tab **Stations (F7)**. If the tab is not shown, select it with pressing **F7**.

Perform the following steps to create a new station with the **Communication assistant**:

1. Click on **Communication assistant** in the Commander-window

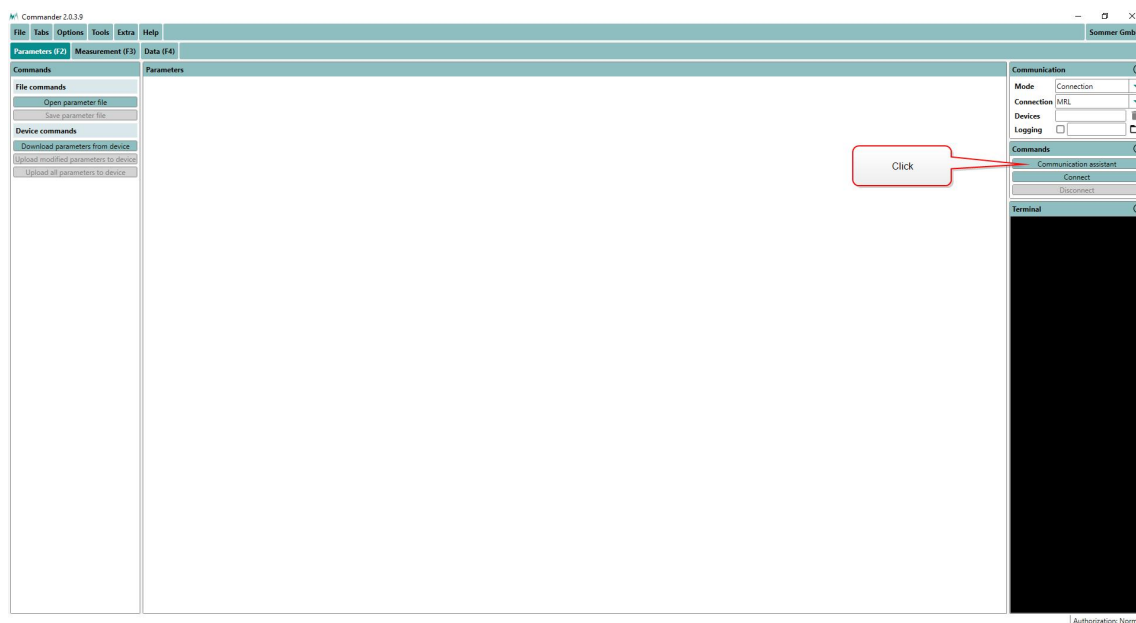

2. In the pop-up window choose the required connection and click [Next](#).

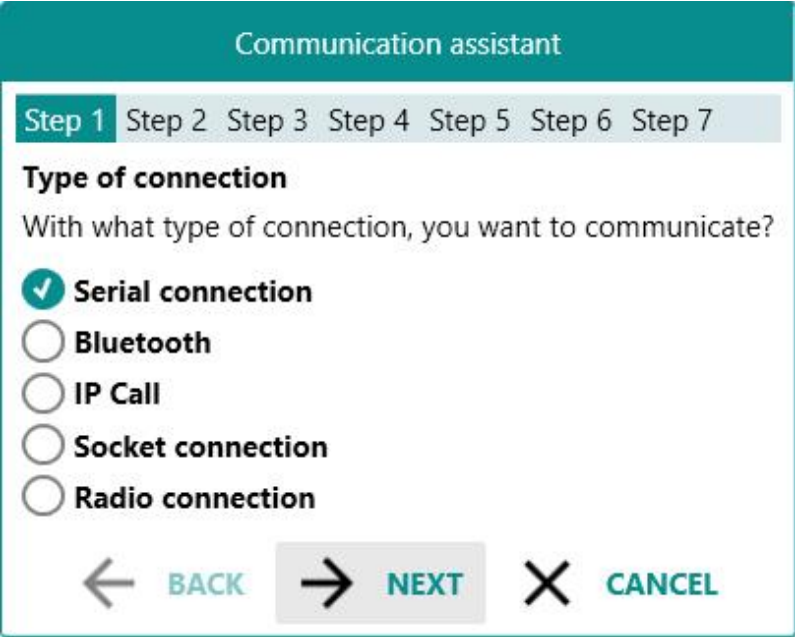

3. Verify that the IDS-30cr is connected to your PC and a power supply. Click [Next](#).

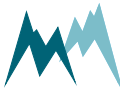

4. Select *Logger (115200 Bd)* and click *Next*.

Communication assistant

Step 1 Step 2 **Step 3** Step 4 Step 5 Step 6 Step 7

Serial connection: Device type

With what type of device, you want to communicate?

Logger (115200 Bd) (MRL-6, MRL-7, RQ-30 ADMS)

Sensor (9600 Bd) (RQ-30, RG-30, SQ-X, SQ-X, SV-a)

Modbus (19200 Bd) (Only for devices set to Modbus)

Or should a port be checked with changing settings?

Check port Baud rate, Parity and stop bits

5. Select *Scan ports* and click *Next*.

Communication assistant

Step 1 Step 2 Step 3 **Step 4** Step 5 Step 6 Step 7 Step 8 Step 9

Serial connection: Connection

Do you want to communicate with an existing or new connection?

Baud rate 9600

Existing connection

Connection

New connection

Select port

Scan ports

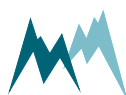

6. The Commander now scans all available ports.

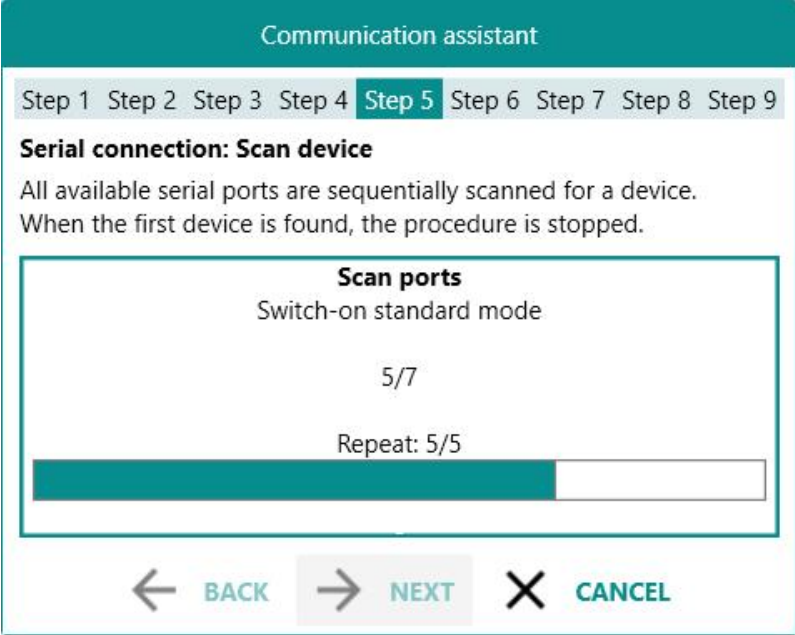

7. Adopt the *Name* provided by the communication assistant. Click *Next*.

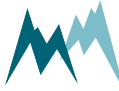
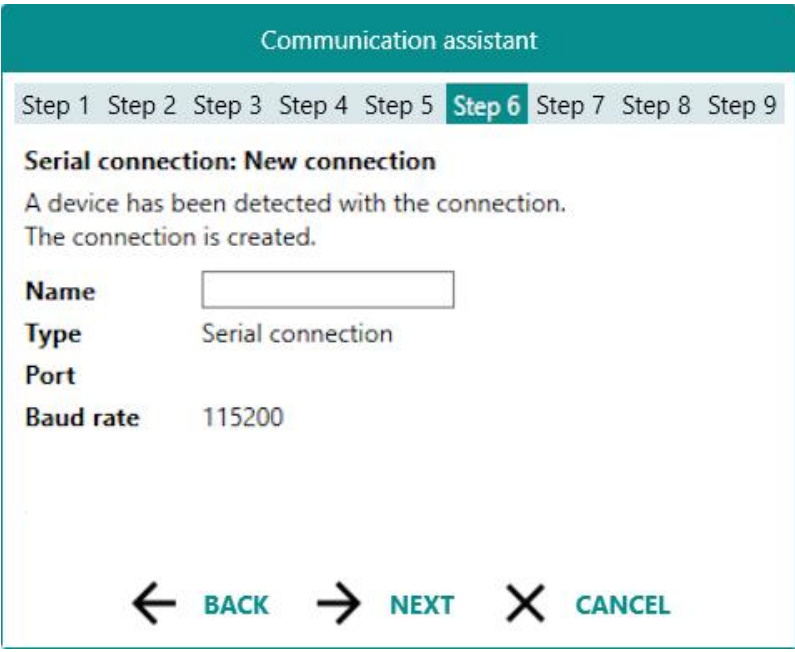

8. The Commander now scans the selected port for connected devices.

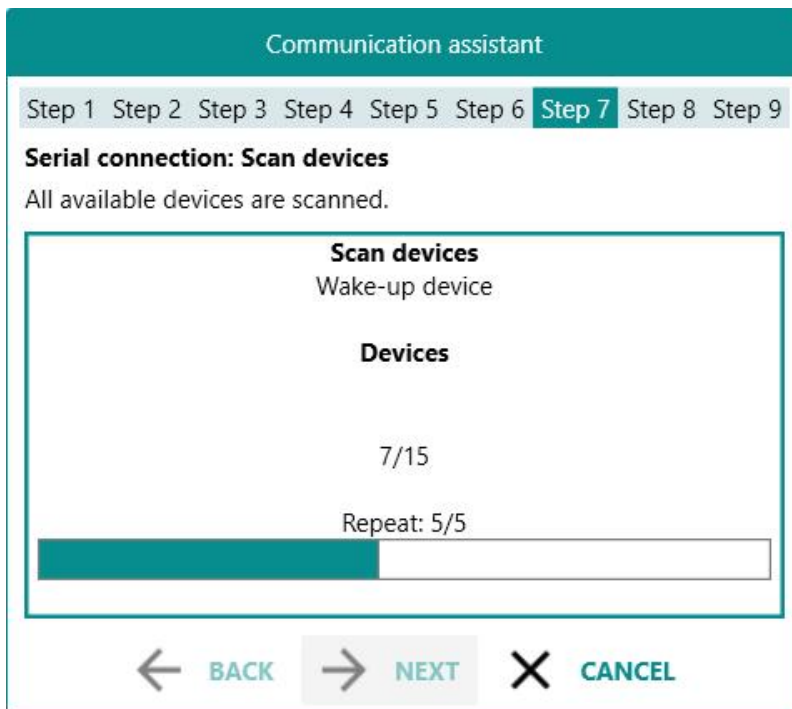

9. Adopt the *Name* of the new station or enter a new name. Click *Next*.

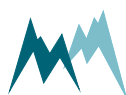
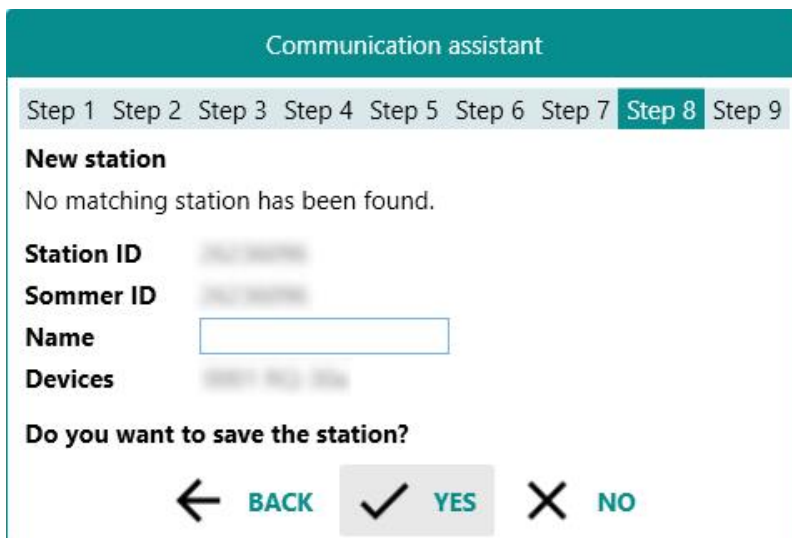

10. A new station has now been created. Click **Finish**.



11. The newly created station can now be selected in the **Communication** section of the Commander. Click **Connect** to activate the connection to your device.

10.6.2 Create a station manually

In order to manage several data loggers, to connect to a data logger via IP-call and to download data, stations can be created in the Commander software. To view a list of all stations select the tab **Stations (F7)**.

Perform the following steps to create a new station:

1. In the tab-menu **Stations (F7)** click **New station**.
2. Under **Station settings** enter the **Station number** and **Sommer ID**. By default both settings are set to the device's serial number (visible on the IDS-30cr housing).
3. Select the **Connections** used for the station. Multiple selections are possible; the default connection can be selected by ticking the circular field.
4. Depending on the connection type, enter the additional information, e.g. **Address** for a Bluetooth connection or **IMSI number** for an IP call.
5. Enter the settings for **Data** management. When data are downloaded from a connected IDS-30cr they are stored in an archive-file by default. Each archive-file contains the data of a year or month, as selected in **Archive type**. Selection **None** will save all data in one file. The default location for data files is C:\Users\Public\Documents\Sommer\Data\.
6. Save the newly created station with the button **Save station**.

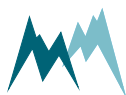

10.7 Working with measurements

10.7.1 Poll continuous measurements

1. Establish a connection to your device as described in [Working with connections](#).
2. Download the setup of your device as described in [Download setup](#).
3. Select the [Measurement \(F3\)](#) tab.
4. In the [Commands](#) section click [Start polling measurement](#).
5. Select the option [Polling with measurements](#). Now, the Commander will trigger measurements of the IDS-30cr without any delays between measurements. The results are displayed [Measurement values](#) and plotted in the [Measurement data graph](#).
6. To finish polling mode click [Stop polling](#).

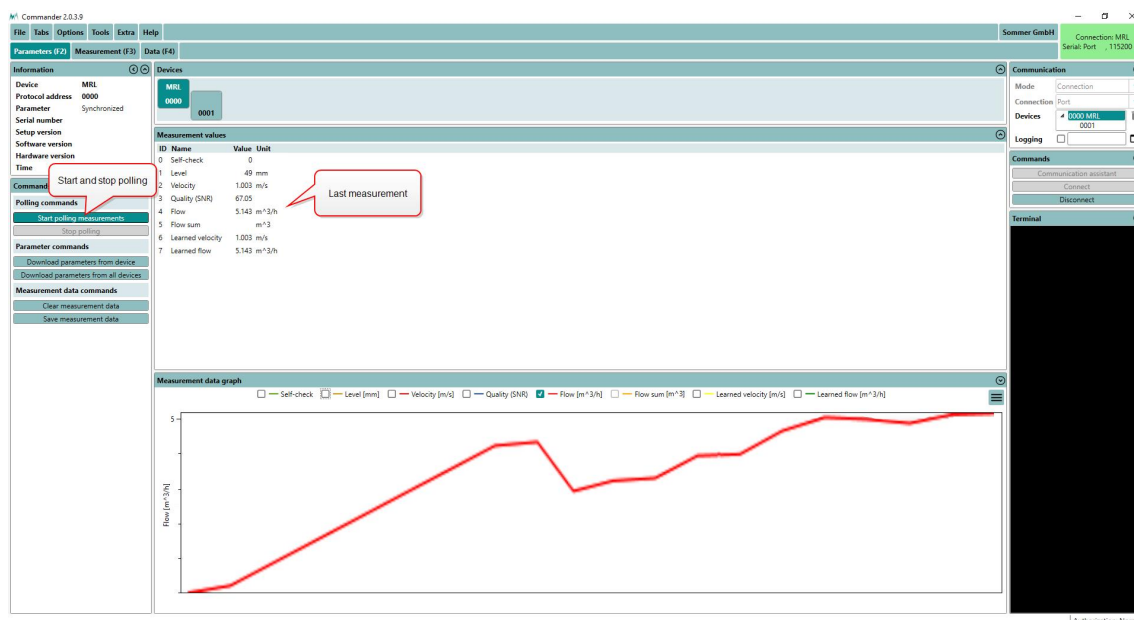

NOTE The polling mode stops automatically after 30 minutes.

10.7.2 Record measurements

1. Establish a connection to your device as described in [Working with connections](#).
2. Download the setup of your device as described in [Download setup](#).
3. Select the [Measurement \(F3\)](#) tab.
4. Make sure that [Measurement output](#) is set to [Measured values push](#) or [Storage values push](#).

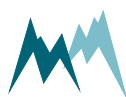

- If the connection with your device is active, the data will now be displayed in the measurement table and updated at the interval specified in the setup. Also, the incoming data strings are displayed in the [Terminal](#).
- Click [Save measurement data](#) in the [Commands](#) section to save the recorded measurements. The data are saved as a *.csv file in the SommerXF format.



NOTE You can change the scope of the data output in the setup [Information](#).

10.8 Working with data

10.8.1 View live data

Follow the steps below to view live data acquired from your device:

- Establish a direct or remote connection with the IDS-30cr using the Commander. Use an existing Commander-connection or -station if available.
- In the [Parameters \(F2\)](#) tab download the parameters of the IDS-30cr.
- Now, there are two options to view the measurement data:
 - If [Measurement output](#) is set to *Measured values push* or *Storage values push*, data are displayed in the [Measurement \(F3\)](#) tab in the specified measurement interval.
 - Open the [Measurement \(F3\)](#) tab and click [Start polling measurements](#). This measurement mode can be stopped by clicking [Stop polling](#), or it is finished automatically after 30 minutes.

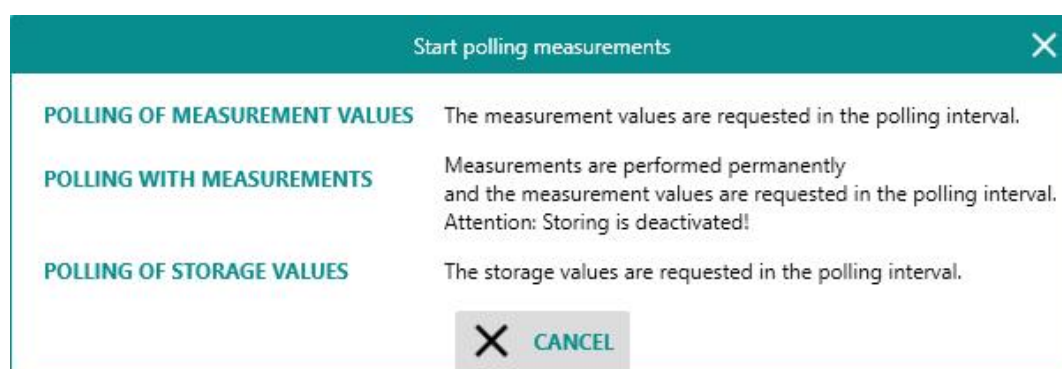

10.9 Working with spectra

10.9.1 Record spectrum

1. Establish a connection to your device as described in [Working with connections](#).
2. Download the setup of your device as described in [Download setup](#).
3. Select the [Measurement \(F3\)](#) tab.
4. Click [Start spectrum mode](#) in the [Commands](#) section. Now the Commander collects the spectrum data and displays them in [Spectrum graph](#).



NOTE The collection of the spectrum data may require some time.

5. Click [Save spectrum file](#) in the [Commands](#) section to save the recorded spectra. The data are saved as a *.xlms file.



NOTE The number of acquired spectra is displayed at the bottom of the [Spectrum graph](#). You can navigate through the spectra by clicking the navigation buttons.

6. Click [Stop spectrum mode](#) to quit recording spectra.

10.9.2 Read spectrum file

1. Open the Commander.
2. Click [Open spectrum file](#) in the [Commands](#) section.
3. Select the desired spectrum file (*.xmls) and click [Open](#). The spectra are now opened and displayed in the [Spectrum graph](#).



NOTE The number of acquired spectra is displayed at the bottom of the [Spectrum graph](#). You can navigate through the spectra by clicking the navigation buttons.

10.10 Working with setups

10.10.1 Download setup

1. Establish a connection to your device as described in [Working with connections](#).
2. Select the [Parameters \(F2\)](#) tab in the Commander software.
3. In the [Commands](#) section click [Download parameters from device](#).

The Commander now downloads the setup currently active on the IDS-30cr. This may take some time if you are downloading the setup for the first time to your PC. Consecutive downloads of a setup with the same version number will be faster as the parameter structure is already available.

You can now save the setup file by clicking [Save parameter file](#), or edit the settings as described in [Edit setup](#).



TIP Save the setup on your PC before you make any changes!

10.10.2 Open a setup file

1. Start the Commander on your PC and connect to your IDS-30cr either directly with the USB to RS232 isolated converter cable or, if available, the optional Bluetooth connection.
2. Open the [Parameters \(F2\)](#) tab and click [Open parameter file](#). Select the required file (extension .xml or .xmla).

10.10.3 Edit setup

1. Open the setup file as described in [Open a setup file](#) or download it from your device as described in [Download setup](#).
2. Adapt the values of the settings in question and press Enter after each. After you have changed a value, its text box will turn red.



NOTE If you have entered a value outside the data range of the setting, it will be forced to the next valid value! The valid range of each setting is listed in the [Parameter definitions](#).

3. After you have adapted all required settings save the setup file and/or upload the setup to your device by clicking [Upload modified parameters to device](#).

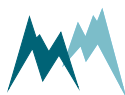

Once the setup has been saved or uploaded, the modified red text boxes will turn white again, indicating that the settings have been saved/applied.

10.10.4 Upload new setup file

1. Establish a connection to your device as described in [Working with connections](#).
2. Select the [Parameters \(F2\)](#) tab.
3. Download the setup currently on the IDS-30cr as described in [Download setup](#) and save it by clicking [Save parameter file](#). This step is recommended to have the latest setup available for documentation.
4. Click [Open parameter file](#) and select the required setup file (*.xlmd) on your PC.
5. Click [Upload all parameters to device](#). This transfers the current setup to the IDS-30cr.
6. To verify the correct upload click [Download parameters from device](#). This will display the present setup of the IDS-30cr.

10.11 Update firmware

1. Connect the IDS-30cr to your PC with the USB to RS485 isolated converter cable.
2. Make sure no connection is active in the Commander (no green icon at the top-right corner).
3. Click on the menu item [Extra](#) and select [Start Programmer](#).
4. Select the firmware file (*.hex) provided by SOMMER Messtechnik. Make sure the file is stored on your PC and not on a USB or network drive.
5. Choose the COM-port the data logger is connected to and a Baud-rate of 57'600.
6. Perform the following three steps in short sequence:
 - Click [Program](#)
 - Unpower the data logger
 - Wait 3...5 seconds to enable full activation of the bootloader and a correct restart (capacitors must be discharged, and if the device had been in sleep mode, this can take some time)
 - Repower the data logger

The firmware currently present on the data logger is now erased and the new one copied to the data logger. During the update process the pop-up window may show the following messages:

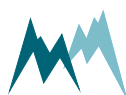

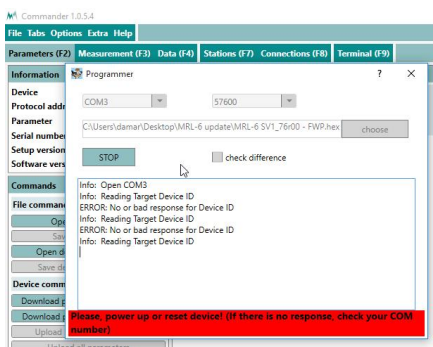

The device is not ready; power needs to be on.

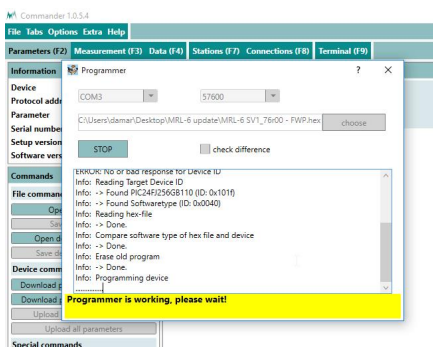

The programmer is active.

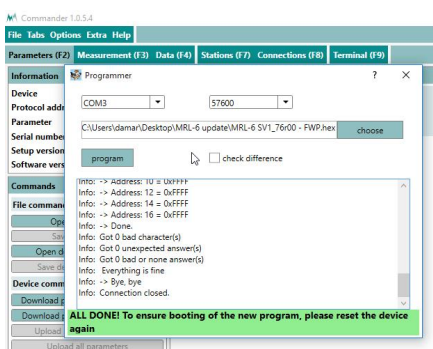

The firmware update has finished.

7. Close the programmer-window as soon as the firmware update has finished.
8. Switch off and repower the data logger again.
9. Open the **Parameters (F2)** tab.
10. Click **Download parameters from device**. The download of the new parameter list might take a few minutes as the parameter structure may need to be downloaded as well. After completion the new firmware and setup versions will be displayed in the **Information** section.

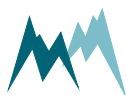

11 Configuration of the IDS-30cr

11.1 Software tools

The IDS-30cr can be configured with one of the following tools:

- Configuration with Commander support software
- Configuration with a terminal program

11.2 Configuration with Commander support software

Follow the steps below to modify the configuration parameters of the IDS-30cr:

1. Establish a connection between your PC and the IDS-30cr.
2. Click [Download parameters from device](#). The complete parameter list is transferred from the IDS-30cr to your PC and displayed in the Parameter window.

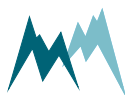



NOTE The first download of the parameter list may take a few minutes. After that the device is known to the PC and consecutive downloads are much faster.



3. Save the parameter file to your PC by clicking **Save parameter file**. This step is recommended to track any configuration changes.

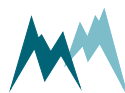
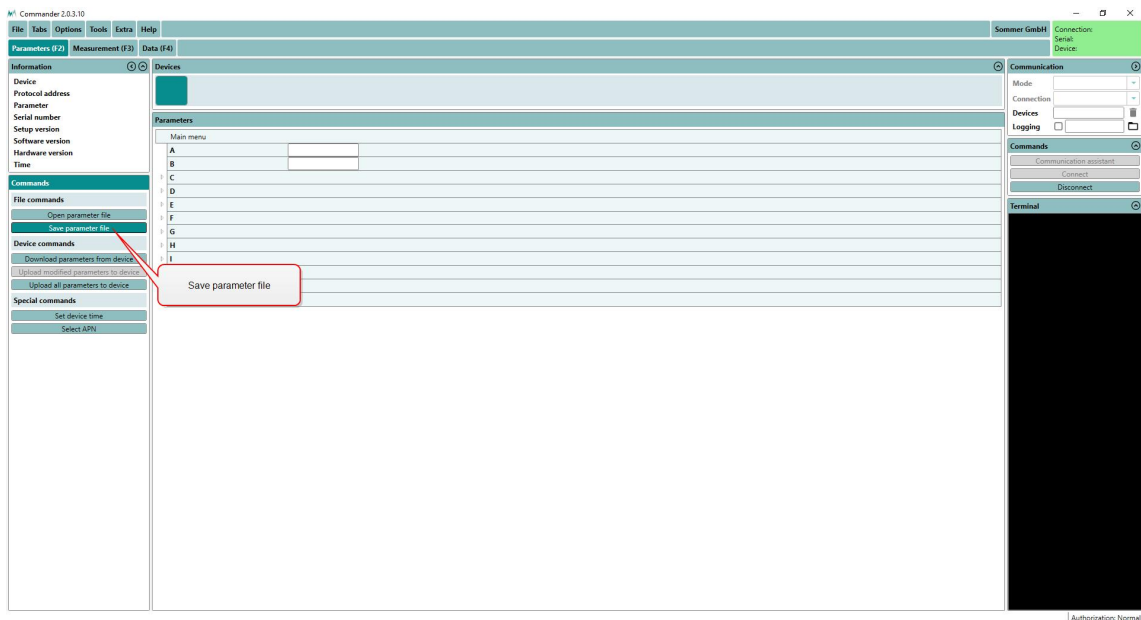

4. Adapt the parameters required for your application. Changed values are displayed with a pink background.

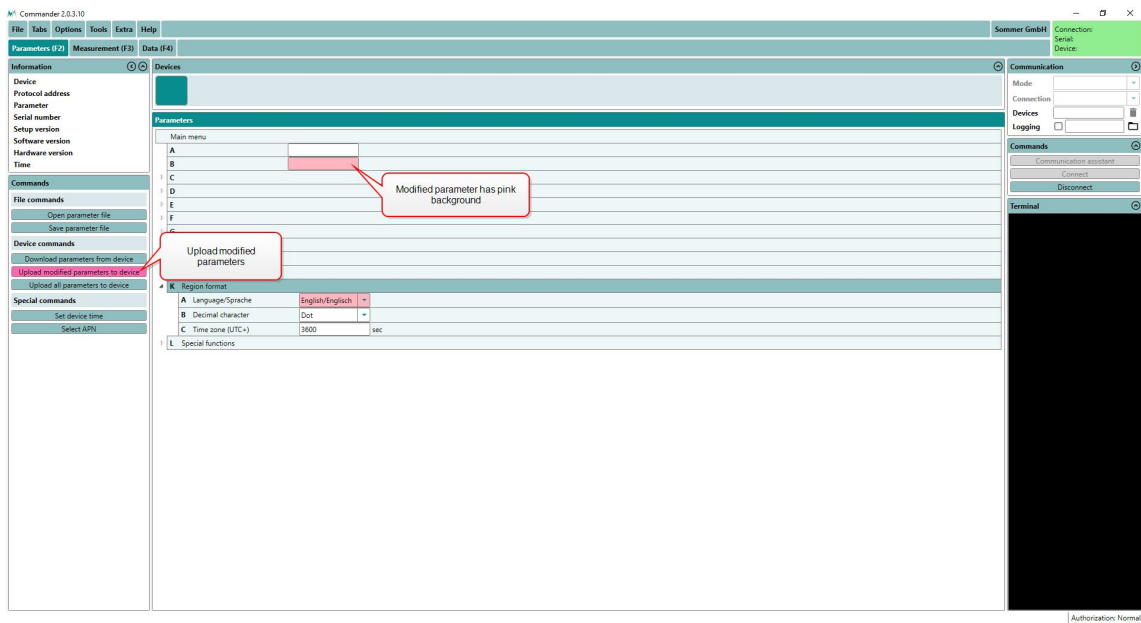

5. Send the modifications to the IDS-30cr by clicking **Upload modified parameters to device**. Upon successful upload the pink backgrounds disappear again.

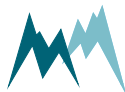

11.3 Configuration with a terminal program

The Commander software ships with an integrated terminal program. However, communication with the IDS-30cr can be performed with any terminal program.

Follow the steps below to modify the configuration parameters of the IDS-30cr:

1. Establish a connection between your PC and the IDS-30cr.
2. In the terminal window enter three question marks (???) in quick succession. The main parameter menu is displayed in response.

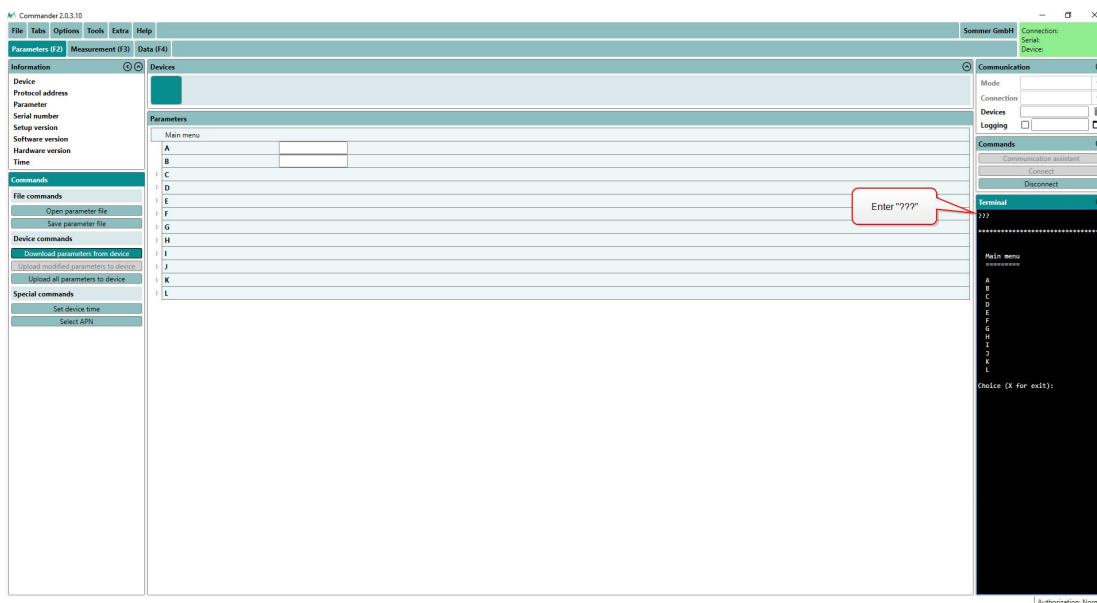

NOTE As an unwanted switching into the menu mode must be avoided the timing of the three question marks ??? is very restrictive and must never be finished with Return/Enter. This is especially important for command line tools, which automatically send a closing "Carriage return". Before and after sending ??? no communication must occur for 1 second.

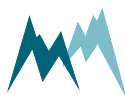

3. Read or modify the required parameters: The menu items can be selected by entering the letter assigned to each item. Upon selection a submenu is opened or the selected parameter is displayed with its unit. Changes to values are confirmed with **Return/Enter** or discarded with **Esc**. Menus are closed with **X** or **Esc**. After closing the main menu with **X** the device performs an initialization.

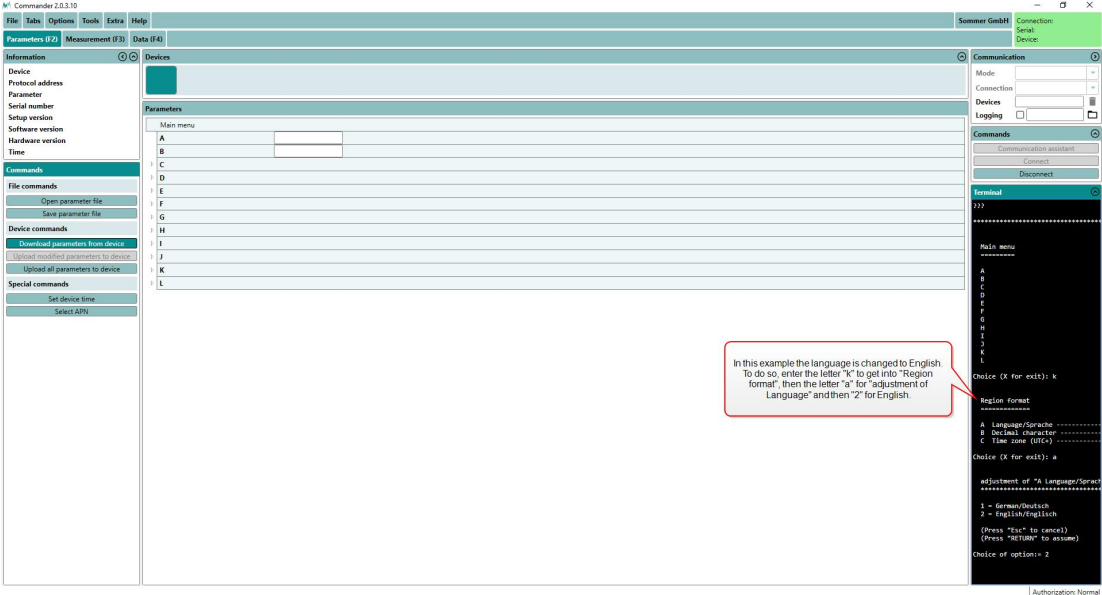

11.4 General settings

When first setting-up a IDS-30cr at a measurement site, the parameters described below may need to be adapted.

11.4.1 Language/Sprache

The menu language.

11.4.2 Decimal character

The character used as decimal separator in the values of the settings, in serial data strings and in .csv files.

11.4.3 Units and decimals

The units and number of decimal digits. These have to be set prior to all other settings as all values are saved internally in this format. They are set in the parameter menu **Units and decimals**.

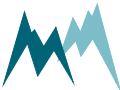



ATTENTION If units or decimals are changed, related parameters may need to be adjusted.

11.4.4 Output protocol (OP)

The type of the serial output protocol. The following options are available:

ID	Option	Description
1	Sommer (SBP) (default)	Sommer Bus Protocol; data values are returned with an index starting at 1. Multiple strings may be returned.
2	Standard	Standard protocol; data values are returned without an index in one string.
3	MODBUS	Modbus protocol

11.4.5 Information

The main measurement values are always included in the data output string. Additionally, special and analysis values can be included.

ID	Option	Description
1	Main values	Only the main values are returned.
2	& Special values (default)	Main values and special values are returned.
3	& Analysis values	Main, special and analysis values are returned.

11.5 Sensor setup

The following sensor adjustments are performed by Sommer Messtechnik before delivery and generally do not need to be done by the user.

11.5.1 Cube 5, zero adjust

After installation of the IDS-30cr it needs to be verified that the sensor does not introduce any interfering capacities. This can be tested with the function **Cube 5, test**, which reads the currently meas-

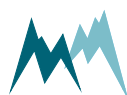

ured capacities of all sensor plates. Use the zero adjust functions to compensate for any capacities introduced by the sensor cables.

11.5.2 Rod 80, zero adjust

After installation of the IDS-30cr it needs to be verified that the sensor does not introduce any interfering capacities. This can be tested with the function [Rod 80, test](#), which reads the currently measured capacities of all sensor plates. Use the zero adjust functions to compensate for any capacities introduced by the sensor cables.



ATTENTION The zero adjust functions should only be applied during installation with dry sensor surfaces. Do not use this function during continuous operation as this may introduce a shift of icing measurements!

11.6 Heater configuration

11.6.1 Ice, maximum

The maximum ice accumulation before the sensor starts heating.

11.6.2 Ice, minimum

Thickness of the accumulated ice layer at which heating stops. This limit is only active in combination with the [Water, minimum](#) setting.

11.6.3 Water, maximum

The maximum water accumulation before the sensor starts heating.

11.6.4 Water, minimum

Thickness of the accumulated water layer at which heating stops. This limit is only active in combination with the [Ice, minimum](#) setting.

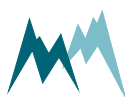

11.6.5 Maximum heating time

The maximum heating duration for one heating cycle. It prevents excess heating and damage of an ice-sensor. Generally, an ice-sensor is defrosted and dried in less than the default 600 sec. Except for extremely harsh environments it is recommended to use the default value.

11.6.6 Cool down duration

The time required to cool down the ice-sensor to ambient conditions.

11.6.7 Meas. duration icing rate

It is recommended to determine the icing-rate over a longer period than a single measurement interval. This period can be specified with the icing-rate measurement duration.

11.7 Icing verification

With the IDS-30cr icing of a connected sensor is verified by the following variables. All three conditions must be satisfied for ice to accrete on a sensor.

11.7.1 Maximum temperature

The temperature below which icing may occur. This depends on the meteorological conditions at the measurement site, e.g. wind speed, humidity or precipitation and may reach a few degrees Celsius plus.

11.7.2 Maximum water

The thickness of the water layer on the sensor below which icing may occur.

The result of the icing verification is also returned with the analysis values (indices 26 and 40). See [Measurement phases](#) for details.

11.8 Relay switching

The IDS-30cr provides two relay outputs which can be configured to switch according to different limit values of the connected sensors.

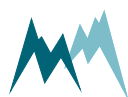

11.8.1 Output value

The variable which controls relay A and/or B; either ice, water or ice and water. Different variables of the same sensor or the same variable of both sensors can be selected.

11.8.2 Ice limit

The amount of ice accreted before the relay is switched.

11.8.3 Ice rate limit

The rate at which ice accumulates before the relay is switched.



12 Communication

12.1 Communication protocols

The IDS-30cr provides the following communication protocols:

- [RS-485](#) (Sommer Bus Protocol)
- [Modbus](#)
- [SDI-12](#)

12.2 Data output

The measurement values returned by the IDS-30cr are arranged in a fixed sequence and identified by an index. They are divided into three groups and can be selected in [Information](#).

12.2.1 Main values

Index	Value	Unit	Description
01	Relay A	0 / 1	State of relay A
02	Relay B	0 / 1	State of relay B
03	Relay function	0 / 1	State of measurement device
04	Cube 5, ice	mm	Current ice layer thickness on Cube 5 sensor
05	Cube 5, ice rate	mm/h	Current icing rate on Cube 5 sensor
06	Cube 5, temp	°C / F	Surface temperature of Cube 5 sensor
07	Rod 80, ice	mm	Current ice layer thickness on Rod 80 sensor
08	Rod 80, ice rate	mm/h	Current icing rate on Rod 80 sensor
09	Rod 80, temp	°C / F	Surface temperature of Rod 80 sensor

Table 2 Main values

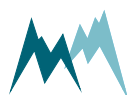

12.2.2 Special values

Index	Value	Unit	Description
10	Relay A, counter		Sum of trigger events of relay A
11	Relay A, time	h	Total time relay A is on
12	Relay B, counter		Sum of trigger events of relay B
13	Relay B, time	h	Total time relay B is on
14	Heating current	A	Heating current
15	Supply Voltage	V	Supply voltage
16	Exception code		for diagnostic use of Sommer Messtechnik only
17	Cube 5, water	mm	Current water layer thickness
18	Rod 80, water	mm	Current water layer thickness

Table 3 Special values

12.2.3 Analysis values

Index	Value	Unit	Description
19	Cube 5, meas. ph		Measurement phase of the sensor, see Measurement phases
20	Cube 5, ice raw	mm	Current ice layer thickness, not verified
21	Cube 5, C P1 LF	pF	Capacity
22	Cube 5, C P1 HF	pF	Capacity
23	Cube 5, C P2 LF	pF	Capacity
24	Cube 5, C P2 HF	pF	Capacity
25	Cube 5, C P3 LF	pF	Capacity

Index	Value	Unit	Description
26	Cube 5, C P3 HF	pF	Capacity
27	Cube 5, P P1 LF	°	Phase of the electrical signal
28	Cube 5, P P1 HF	°	Phase of the electrical signal
29	Cube 5, P P2 LF	°	Phase of the electrical signal
30	Cube 5, P P2 HF	°	Phase of the electrical signal
31	Cube 5, P P3 LF	°	Phase of the electrical signal
32	Cube 5, P P3 HF	°	Phase of the electrical signal
33	Rod 80, meas. ph		Measurement phase of the sensor, see see Measurement phases
34	Rod 80, ice raw	mm	Current ice layer thickness, not verified
35	Rod 80, C P1 LF	pF	Capacity
36	Rod 80, C P1 HF	pF	Capacity
37	Rod 80, C P2 LF	pF	Capacity
38	Rod 80, C P2 HF	pF	Capacity
39	Rod 80, C P3 LF	pF	Capacity
40	Rod 80, C P3 HF	pF	Capacity
41	Rod 80, P P1 LF	°	Phase of the electrical signal
42	Rod 80, P P1 HF	°	Phase of the electrical signal
43	Rod 80, P P2 LF	°	Phase of the electrical signal

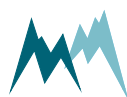

Index	Value	Unit	Description
44	Rod 80, P P2 HF	°	Phase of the electrical signal
45	Rod 80, P P3 LF	°	Phase of the electrical signal
46	Rod 80, P P3 HF	°	Phase of the electrical signal

Table 4 Analysis values

12.2.4 Exception values

Measurement data may be returned with the following exception values:

Value	Description
99999998	Initial value: No measurement has been performed yet.
99999997	Conversion error: Caused by a technical problem.
99999999	Positive overflow
-99999999	Negative overflow

Table 5 Exception values

12.3 RS-485

12.3.1 What is RS-485?

RS-485 is a serial communication method for computers and devices. It is currently a widely used communication interface in data acquisition and control applications where multiple nodes communicate with each other.¹

¹<https://www.lammertbies.nl/comm/info/RS-485.html>

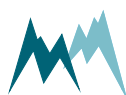

12.3.2 What can I do with it?

RS-485 communication is primarily used to trigger measurements and read their results. It also permits to change parameters of the IDS-30cr.

12.3.3 Configuration

The IDS-30cr has serial RS-485 communication enabled by default. If the device is integrated into a RS-485 network or connected to a stand-alone data acquisition system, e.g. a data logger, the parameters listed in [Output protocol](#) may need to be adapted.

12.3.3.1 System key and device number

The system key and device number are used to identify a IDS-30cr in a bus system. This is essential if multiple devices (IDS-30cr and data loggers) are operated within the same system.

System key

The system key separates different conceptual bus systems. This may be necessary if the remote radio coverage of two measurement systems overlap. In wired setups, the system key should be set to *00*.

Device number

The device number is a unique number that identifies a device in a bus system.



ATTENTION Do not use a device number twice in your bus system! Otherwise communication will fail!

12.3.3.2 Measurement output

The serial data output can be triggered in the following ways:

ID	Option	Description
1	Just per command	The output is only requested by commands via RS-485.
2	After measurement (default)	The serial data output is performed automatically right after each measurement.
3	Pos. TRIG slope	The output is triggered by a positive edge of a control signal applied to the trigger input.



NOTE If **Measurement output** is set to *pos. TRIG slope*, the data are returned with a delay of 200 ms after the trigger has been set. Make sure that your data acquisition system takes account of this lag to ensure that it receives the most recent data.

12.3.3.3 Operation modes

The selected combination of measurement trigger and output time determines the following operation modes:

Parameter	Mode		
	Pushing	Polling	Apparent polling
Measurement trigger	internal	TRIG input SDI-12/RS485	TRIG input SDI-12/RS485
OP, measurement output	after measurement	just per command	after measurement

12.3.3.4 Waking-up a connected data logger

The IDS-30cr supports wake-up of a connected data logger that is in standby mode. Generally, this feature is only used in pushing and can be set under [Wake-up sequence](#).

12.3.3.4.1 Sync sequence

The sync sequence is the string `UU~???` and is sent directly before a command. It is used to synchronize the receiving UART.

12.3.3.4.2 Prefix

The prefix is an arbitrary character; the IDS-30cr uses a blank. This character is sent prior to any communication. Then the time of the [Prefix holdback](#) is waited and the command is sent afterwards. With this procedure the receiving device has time to wake-up.

12.3.3.5 Output protocols

For data output via RS-485 different protocols are available, which can be selected under [Output protocol \(OP\)](#).

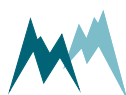

12.3.4 Data output options

Data are returned in two different formats, selectable in [Output protocol \(OP\)](#):

- Sommer Bus Protocol (SBP)
- Standard protocol

12.3.5 Sommer Bus Protocol (SBP)

The data string of the Sommer Bus Protocol has the following format:

 **EXAMPLE** #M0001G01se01 1461|02 1539|03 25.25|04
0|ADC9;

A data string contains max. 8 values and is max. 105 characters long.

12.3.5.1 Header

The header (#M0001G01se) identifies the data by system key, device number and string number.

Parameter	Format	Description
Start character	#	
Identifier	M	M identifies an output string
System key	dd	
Device number	dd	
Command ID	G	G defines an output string with string number
String number	dd	01 Main values 03 Special values 05 Analysis values 06 Analysis values
Command	se	se identifies automatically sent values

Table 6 Header of the Sommer Bus Protocol

12.3.5.2 Measurement value

A measurement value (02 1539|) has a length of 8 digits and is returned together with its index. If the measurement value is a floating point number, one digit is reserved for the decimal character. Values are returned right-aligned, so blanks may occur between index and value.

Parameter	Format	Description
Index	dd	2 numbers
Value	xxxxxxxx	8 character right-aligned
Separator		

Table 7 Values in Sommer Bus Protocol

12.3.5.3 End sequence

The data string is terminated with a CRC-16 in hex format (ADC9) followed by an end character and <CR><LF>. The CRC-16 is described in [Sommer Messtechnik CRC-16](#).

Parameter	Format	Description
CRC-16	hhhh	4-digit hex number
End character	;	
Control characters	<CR><LF>	Carriage return and Line feed

Table 8 End sequence of the Sommer Bus Protocol

12.3.5.4 Example Sommer Bus Protocol

12.3.5.4.1 Main values

Main values are returned as in the following example:

**EXAMPLE**

```
#M0001G01se01      0|02      0|03      0|04
0,0|05      0|06      23,6|4DCD;
```

#M0001G01se		Header with system key 00, device number 01 and string number 01
01	0	Relay A
02	0	Relay B
03	0	Relay function
04	0,0	Ice
05	0	Ice rate
06	23,6	Sensor Temperature
4DCD;		Closing sequence

Table 9 Main values in Sommer Bus Protocol

12.3.5.4.2 Special values

Special values are returned as in the following example:

**EXAMPLE**

```
#M0001G10se07      0|08      0,0|09      -1|10
0,0|AA0D;

#M0001G11se11      0,00|12      12,39|13      64,00|14
25,6|76AE;
```

#M0001G10se		Header with system key 00, device number 01 and string number 10
07	0	Relay A, counter
08	0,0	Relay A, time
09	-1	Relay B, counter
10	0,0	Relay B, time

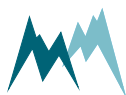

AA0D;	Closing sequence
#M0001G11se	Header with system key 00, device number 01 and string number 11
11 0,00	Heating current
12 12,39	Supply Voltage
13 64,00	Exception code
14 25,6	Water
76AE;	Closing sequence

Table 10 Special values in Sommer Bus Protocol

12.3.5.4.3 Analysis values

Analysis values are returned as in the following example:

✓	EXAMPLE			
	#M0001G20se15	0,05 16	0,0 17	64,04 18
	64,42 C183;			
	#M0001G21se19	66,20 20	67,16 21	66,19 22
66,75 71E8;				
#M0001G22se23	-89,87 24	-90,77 25	-90,33 26	-
90,96 1C22;				
#M0001G23se27	-89,73 28	-90,85 FE03;		

#M0001G20se	Header with system key 00, device number 01 and string number 20
15 0,05	Measurement phase
16 0,0	Ice raw
17 64,04	C P1 LF
18 64,42	C P1 HF
C183;	Closing sequence

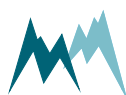

#M0001G21se	Header with system key 00, device number 01 and string number 21
19 66,20	C P2 LF
20 67,16	C P2 HF
21 66,19	C P3 LF
22 66,75	C P3 HF
71E8;	Closing sequence
#M0001G22	Header with system key 00, device number 01 and string number 22
23 -89,87	P P1 LF
24 -90,77	P P1 HF
25 -90,33	P P2 LF
26 -90,96	P P2 HF
1C22;	Closing sequence
#M0001G23se	Header with system key 00, device number 01 and string number 23
27 -89,73	P P3 LF
28 -90,85	P P3 HF
FE03;	Closing sequence

Table 11 Analysis values in Sommer Bus Protocol

12.3.6 Standard protocol

The data string of the Standard protocol has the following format:

	EXAMPLE M_0001	1461	1539	25.25	0
---	-----------------------	------	------	-------	---

12.3.6.1 Header

The header (M_0001) identifies the data by system key and device number.

Parameter	Format	Description
Identifier	X_	M_ Measurement values S_ Special values V_ Analysis values
System key	dd	
Device number	dd	

Table 12 Header of the Standard protocol

12.3.6.2 Measurement values

Measurement values are returned in sequence and are separated by a blank. A measurement value has a length of 8 digits. If the measurement value is a decimal number, one digit is reserved for the decimal character. Values are returned right-aligned, so additional blanks may be returned between values.

Parameter	Format	Description
Separator	[blank]	blank
Value	xxxxxxxx	8 character right-aligned

Table 13 Values in Standard protocol



NOTE With the standard protocol the data strings can be very long. In contrast, the strings of the Sommer Bus Protocol are max. 105 characters long.

12.3.6.3 End sequence

The data string is terminated with <CR><LF>.

12.3.6.4 Example Standard protocol

12.3.6.4.1 Main values

Main values are returned as in the following example:

	EXAMPLE	M_0001	0	0	0	0,0
		0	23,7			

M_0001	Header with identifier for measurement values
0	Relay A
0	Relay B
0	Relay function
0,0	Ice
0	Ice rate
23,7	Sensor Temperature

Table 14 Main values in Standard protocol

12.3.6.4.2 Special values

Special values are returned as in the following example:

	EXAMPLE	S_0001	0	0,0	-1	0,0
		-0,01	12,39	64,32	25,6	

S_0001	Header with identifier for measurement values
0	Relay A, counter
0,0	Relay A, time

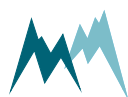

-1	Relay B, counter
0,0	Relay B, time
-0,01	Heating current
12,39	Supply Voltage
64,32	Exception code
25,6	Water

Table 15 Special values in Standard protocol

12.3.6.4.3 Analysis values

Analysis values are returned as in the following example:

✓	EXAMPLE	V_0001	0,05	0,0	64,03	64,43	
		66,21	67,17	66,21	66,75	-89,87	-90,78 -
		90,34	- 90,96	- 89,73	- 90,85		

V_0001	Header with identifier for analysis values
0,05	Measurement phase
0,0	Ice raw
64,03	C P1 LF
64,43	C P1 HF
66,21	C P2 LF
67,17	C P2 HF
66,21	C P3 LF
66,75	C P3 HF
-89,87	P P1 LF
-90,78	P P1 HF

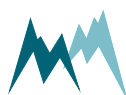

-90, 34	P P2 LF
-90, 96	P P2 HF
-89, 73	P P3 LF
-90, 85	P P3 HF

Table 16 Analysis values in Standard protocol

12.3.7 RS-485 commands

12.3.7.1 Command structure

The structure of serial commands and answers is described in the following table:

Parameter	Format	Description
Start character	#	
Identifier	X	<p>W Write: IDS-30cr returns a confirmation on receipt. This command type demands a closing sequence with a valid CRC-16.</p> <p>S Silent: IDS-30cr does not acknowledge the receipt of the command. This command type demands no closing sequence and therefore no CRC-16.</p> <p>R Read: IDS-30cr returns the requested measurement value or parameter. This command type demands a closing sequence with a valid CRC-16.</p> <p>T Temporary: Write a volatile, temporary setting and receive a confirmation.</p> <p>A Answer: Answer of device to read or write command.</p>
System key	dd	
Device number	dd	
Command	xxx	See table in section Commands .

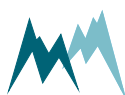

Parameter	Format	Description
Separator		
CRC-16	hhhh	4-digit hex number
End character	;	

Table 17 Structure of Sommer Bus Protocol commands and answers

12.3.7.2 Commands

The following commands can be used with the IDS-30cr:

Command	Description
\$mt	Trigger a measurement
\$pt	Return measurement values
XX	Read a parameter with identifier XX
XX=xxxx	Write a parameter with identifier XX and the value xxx

Table 18 List of Sommer Bus Protocol commands

12.3.7.3 Trigger a measurement

The command \$mt triggers a complete measurement sequence as in the following example:

 **EXAMPLE** #W0001\$mt|BE85; Answer: #A0001ok\$mt|4FA9;

12.3.7.4 Read a parameter value

Read measurement interval (in the example below the menu item B):

 **EXAMPLE** #R0001B|228B; Answer: #A0001B=300|F8B3;

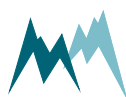

12.3.7.5 Request a complete data string

The command `$pt` requests a data string as in the following example:



EXAMPLE

Option 1

`#W0001$pt|7D19;` `Answer: #A0001ok$pt|8C35;`

Option 2

`#S0001$pt|` `Answer: none`

The data string is returned as soon as the IDS-30cr has processed the command. If a wrong command is entered, the device returns `#A0001na$pt|3D40;`.

12.3.7.6 Request a single measurement value

The reading command `R` together with the index of the requested measurement returns a single measurement value. In the following example the measurement value with index `01` is requested:



EXAMPLE

Measurement Value cv:

`#R0001_010cv|EA62;` `Answer: #A0001ok_010cv1461` `|5D62;`

Storage Value sv:

`#R0001_010sv|F853;` `Answer: #A0001ok_010sv1461` `|1D31;`

12.3.8 Sommer Messtechnik CRC-16

The CRC-16 (cyclic redundancy check) used in data transmission of Sommer Messtechnik devices is based on the ZMODEM protocol. When data are exchanged between two devices the receiving device calculates the CRC-value. This value is compared to the CRC value sent by the other device to check if the data were transmitted correctly. Please refer to technical literature or contact Sommer Messtechnik for calculation of CRC-16 values.

You can [here](#) calculate the CRC of a command online .

If you need to compute CRCs automatically, you can implement the following procedure in your data logger or controller software.

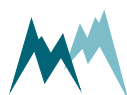

The CRC-16 is calculated character by character. The start value for the initial CRC-16 calculation is always 0.

The following procedure returns the CRC-16 of a single character:

```

byte1 = CRC-16 right shift by 8 bits           upper byte disappears
uint1 = c                                     new character, upper byte = 0
uint2 = CRC-16 left shift by 8 bits           lower byte = 0
uint3 = crc16tab[byte1]                       Table value from the CRC-16 table
Crc16 = uint3 (excl. or) uint2 (excl. or) uint1

```

Computation CRC-16 in C/C++

```
1 | crc16 = crc16tab[(unsigned char)(crc16>>8)] ^ (crc16<<8) ^ (unsigned int)(c);
```

The `crc16tab` array is listed in [CRC-16 array](#).



EXAMPLE

Command to request measurement data `#W0001$pt|7D19;`

The first character is #, the last |. The CRC-16 of the command is 7D19 and its end character is ;.

The CRC-16 is calculated sequentially with the start value 0 for the initial CRC-16 calculation:

Position	String	CRC-16
Start		0000
0	#	0023
1	#W	2357
2	#W0	4331
3	#W00	4997
4	#W000	4EDD
5	#W0001	743B
6	#W0001\$	0537
7	#W0001\$p	67D5
8	#W0001\$pt	C935
9	#W0001\$pt	7D19

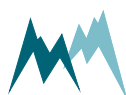

12.4 SDI-12

12.4.1 What is SDI-12?

SDI-12 (Serial Data Interface at 1200 Baud) is a serial data communication standard for interfacing multiple sensors with a single data recorder. For a detailed description on SDI-12 communication please refer to www.sdi-12.org.

12.4.2 What can I do with it?

The IDS-30cr listens to standard SDI-12 commands as listed in the SDI-12 specifications of version 1.3, e.g., to trigger a measurement or retrieve measurement results. Additionally, a set of extended SDI-12 commands is implemented in all SOMMER sensors for instrument configuration.

12.4.3 Configuration

The IDS-30cr has SDI-12 communication enabled by default. When setting up a SDI-12 network take the following considerations into account:

- Each device in the SDI-12 network must have a unique address, e.g. data logger address *0*, IDS-30cr address *1*.
- The IDS-30cr operates in pushing mode and data are retrieved by *R!* commands.
- When multiple sensors are connected to the same network, data acquisition should be done in sequence, i.e., data should have been received from the first sensor before triggering the measurement of the second sensor.
- Most data loggers control the timing of messages (marking and spacing) automatically. If this is not the case, please refer to www.sdi-12.org.

12.4.4 Data structure

The answer from the SDI-12 device is a string containing the sensor address, the requested data and a terminating carriage return/line feed.

In a string containing measurement data, the measurements are returned in the same order as listed by the index in [Data output](#).



EXAMPLE

```
0+2591+706+25.53+62<CR><LF>
```

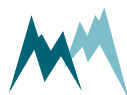



Value	Content
0	Sensor address
2591	Measurement with index 01
706	Measurement with index 02
25.53	Measurement with index 03
62	Measurement with index 04

If a device returns more than 9 measurement values, or if the values are returned in groups (see also [Request results](#)) the measurement index increments in the next group.

**EXAMPLE**

0D0! Answer: 0+2591+706+25.53+62<CR><LF>

0D0! Answer: 0+56.2+125+12.32<CR><LF>

Value	Content
0	Sensor address
2591	Measurement with index 01
706	Measurement with index 02
25.53	Measurement with index 03
62	Measurement with index 04
0	Sensor address
56.2	Measurement with index 05
125	Measurement with index 06
12.32	Measurement with index 07

12.4.5 SDI-12 commands

The following tasks can be performed with standard and extended SDI-12 commands.

Extended SDI-12 commands are non-standard commands implemented by SOMMER to enable device configuration via SDI-12.



NOTE After any changes, the settings have to be adopted with the command `aXW_ts|!`, with `a` the sensor address.

12.4.5.1 Command structure

A standard SDI-12 command starts with the sensor address and ends with an exclamation mark, e.g., 0M! to trigger a measurement.

Configuration commands contain additional information; see the sections below for details.

12.4.5.2 Identify device

The identification of a SDI-12 device is requested with the command aI!, with a the sensor address.



EXAMPLE

0I! Answer 013Sommer USH 140r90 USH-9 <CR><LF>

The answer contains the following information:

0	SDI-12 address
1	SDI-12 version prior to the point
3	SDI-12 version after the point
Sommer	Description of the company (6 characters and 2 blanks)
USH	Description of the firmware (5 characters and 2 blanks)
140r90	Firmware version (6 characters and 2 blanks)
IDS-30cr	Device designation (max. 13 characters)

12.4.5.3 Acquire measurements

To acquire a measurement from a sensor, two individual SDI-12 commands – trigger a measurement and request measurement values – need to be sent.



EXAMPLE

0M! Answer: 00084<CR><LF> and 0<CR><LF> after 8 seconds

0D0! Answer: 0+2591+706+25.53+0<CR><LF>

The first values in the response to the aDn! command is the sensor address.

12.4.5.4 Trigger measurement

The command `aM!` with sensor address `a` triggers a measurement as in the example below.

The response states the measurement duration and the number of measurement values (see example below). After completion of the measurement, the device will return an additional `a<CR><LF>`, with `a` the sensor address.



EXAMPLE

`0M!` Answer: `00084<CR><LF>` and `0<CR><LF>` after 8 seconds

The answer contains the following information:

<code>0</code>	SDI-12 address
<code>008</code>	Duration of the measurement in seconds
<code>4</code>	Number of measurement values

12.4.5.5 Request results

After each measurement, results are requested with the command `aDn!`, with `a` the sensor address and `n` the index of the returned data string.



EXAMPLE `0D0!` Answer: `0+2591+706+25.53+0<CR><LF>`

The leading `0` of the response is the sensor address.

Generally, the command `aD0!` is sufficient to request up to 9 measurement values. If more than 9 values need to be read, or if the values are returned in groups, the commands `aD1!`, `aD2!`,... may need to be issued after `aD0!`. For example, if a measurement returns 8 values in two groups of 4, the commands `aD0!` and `aD1!` need to be issued to receive all values.

12.4.5.6 Acquire continuous measurements

If the SDI-12 device is operating in continuous measurement mode (not polled by SDI-12), the command `aR0!` will request and return the current reading of the sensor. The values within the data string follow the order listed in the measurement table. The first values in the response to the `aRn!` command is the sensor address.

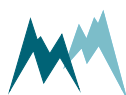

**EXAMPLE**

0R0! Answer: 0+2591+706+25.53+0<CR><LF>

**ATTENTION**

If more than 8 values need to be read, or if the values are returned in groups, the commands aR1!, aR2!,... may need to be issued after aR0!. For example, if a measurement returns 8 values in two groups of 4, the commands aR0! and aR1! need to be issued to receive all values.

12.4.5.7 Configure parameter

The configuration parameters of a SOMMER sensor are read with the command aXRpp! and written with the command aXWpp=vvv!, with a the sensor address, pp the parameter identifier and vvv the value of the parameter.

12.4.5.8 Read and write a parameter**EXAMPLE**

Reading of measurement interval (in this example menu item B)

0XRB|! Answer: 0B=300|<CR><LF>

Setting of measurement interval to 60 s (in this example menu item B)

0XWB=60|! Answer: 0B=60|<CR><LF>

12.4.5.9 Read and write a selector-parameter

Changing the measurement trigger (in the following example menu item A) from *interval* to *SDI-12/RS485*:

**EXAMPLE**

0XRA|! Answer: 0A=1|<CR><LF>

0XWA=3|! Answer: 0A=3|<CR><LF>

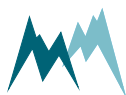

12.4.5.10 Read and write a parameters of a table

Some SOMMER sensors are equipped with multiple transducers and their settings are listed in a table (see example below). A value within such a table is addressed by its row-index (01, 02 ...) and column-index (A, B ...). A corresponding SDI-command has the following format:



EXAMPLE

In this example of a snow scale the value in row 01 and column B of the parameter D-D-E is changed to -1.4.

0XWDDE01B=-1.4|!

Answer: 0DDE01b=-1.4|<CR><LF>

	Identifier	offset zero kg	gain	zero default kg	gain default
01	Load Cell 1	-1.4	0,997787	0,000	0,997787
02	Load Cell 2	0,000	0,997787	0,000	0,997787
03	Load Cell 3	0,000	0,997787	0,000	0,997787
04	Load Cell 4	0,000	0,997787	0,000	0,997787

12.4.5.11 Adopt settings

Some settings need to be adopted with the command `aXW_ts|!`, with `a` the sensor address. It is recommended to issue `aXW_ts|!` after each configuration change.

12.5 Modbus

12.5.1 What is Modbus?

Modbus is a serial communication protocol used for transmitting information over serial lines between electronic devices. The device requesting the information is called the Modbus Master and the devices supplying information are Modbus Slaves. In a standard Modbus network, there is one Master and up to 247 Slaves, each with a unique Slave Address from 1 to 247. The Master can also write information to Slaves.

Modbus has become a standard communication protocol in industry, and is now the most commonly available means of connecting industrial electronic devices. It is often used to connect a supervisory computer with a remote terminal unit (RTU) in supervisory control and data acquisition (SCADA)

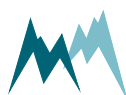

systems. Versions of the Modbus protocol exist for serial lines (Modbus RTU and Modbus ASCII) and for Ethernet (Modbus TCP).¹

12.5.2 What can I do with it?

Modbus-communication with IDS-30cr allows reading of measurement values and device information by a Modbus master. Additionally, the basic RS-485 port settings can be written to the IDS-30cr.

12.5.3 Wiring

For Modbus communication the IDS-30cr is wired according to the table below.

Modbus	Connector MAIN	Connection wire	Description
Common	Pin 1	White	GND
D1 - B/B	Pin 4	Yellow	RS-485 A
D0 - A/A	Pin 5	Grey	RS-485 B

Table 19 Modbus wiring



NOTE

Please note that different signal notations are in use for RS-485 connections:

TX+/RX+ or D+ or D1 as alternative for B

TX-/RX- or D- or D0 as alternative for A



NOTE If the IDS-30cr is operated with multiple Modbus devices within the same network, termination resistors may be required. Please contact Sommer Messtechnik for details.

12.5.4 Modbus configuration

Follow the instructions below to change the communication of a Sommer Messtechnik device (in this example a RG-30) to Modbus:

¹<http://www.simplymodbus.ca/FAQ.htm>

1. Connect the USB to RS-485 converter to the data cable of the Sommer Messtechnik device and a USB port on your PC.
2. Connect the sensor to a power supply with the specified rating.
3. Start the Commander software on your PC.
4. Establish a connection to the Sommer Messtechnik device.
5. Download the sensor's parameters in the **Parameters (F2)** tab and save the parameter list on your PC.



6. In the parameter list navigate to Technics and open the menu **RS485 (COM)** and take a screenshot of the associated parameters. This and the previous step are helpful if you need to switch back to the standard communication mode at a later time.

Parameters			
Main menu			
A	Measurement trigger	Interval	▼
B	Measurement interval	60	sec
▶	C DIG-OUT limit monitor		
▲	D Technics		
▶	A Units Expand		
▲	B SBP device addressing		
A	Device number	01	
B	System key	00	Expand
▲	C RS485 (COM)		
▲	A Output protocol		
A	Output protocol	Sommer	▼
B	Measurement output	After measurement	▼
C	Information	& Special values	▼
D	Wake-up sequence	Prefix	▼
E	Prefix holdback	300	ms
F	MODBUS, set default		
G	MODBUS, device address	35	Expand
▲	B Port		
A	Baudrate	9600	▼
B	Parity, stop bits	No par, 1 stop	▼
C	Minimum response time	10	ms
D	Transmitter warm-up time	10	ms
E	Flow control	Off	▼
F	Sending window	300	ms
G	Receiving window	300	ms
▶	D SDI12 Slave		
▶	E Additional settings		

7. Set **Measurement trigger** to one of the following options:
- Interval*, if measurements are triggered internally by the device.
 - SDI-12/RS-485*, if measurements are triggered by SDI-12.
 - TRIG input*, if measurements are triggered by a trigger input.
 - all allowed*, if measurements are triggered by one of the previous options.

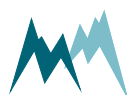



NOTE Modbus cannot trigger measurements! Make sure to use the trigger option suitable for your application!

- Verify that the connection to the Sommer Messtechnik device is active and click into the Terminal window. Type ??? to enter the sensor-menu.

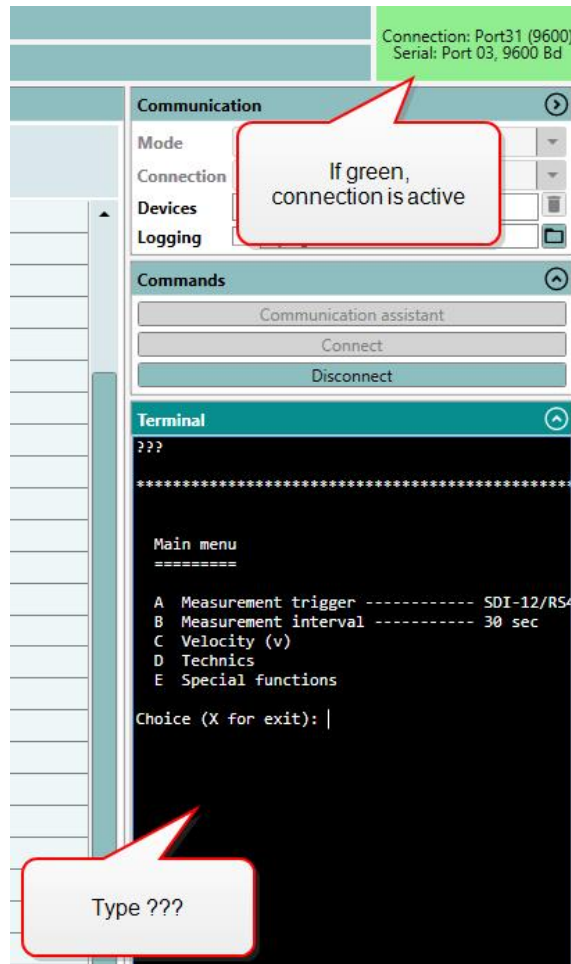

- Navigate to *RS485 protocol* and select *MODBUS, set default...* Please note, that the index-letters might be different for your Sommer Messtechnik device!

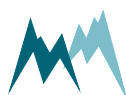

```

Terminal

Main menu
=====

A Measurement trigger ----- SDI-12/RS485
B Measurement interval ----- 30 sec
C Velocity (v)
D Technics
E Special functions

Choice (X for exit): d

Technics
=====

A Language/Sprache ----- english/englisch
B Decimal character ----- dot
C SDI-12 address ----- 1
D Channel type ----- open
E Advanced settings
F Tech. velocity (v)
G RS485 protocol
H RS485
I Units and decimals

Choice (X for exit): g

RS485 protocol
=====

A Device number
B System key --
C Output protocol
D Output (MO) t
E MO information
F MO wake-up se
G MO prefix holdback ----- 100 ms
H MODBUS, set default...
I MODBUS, device address ----- 35

Choice (X for exit): |

```

Enter the letter of 'MODBUS, set default ...'

10. Acknowledge the safety-note.

```

Start up testmode: 0x09

MODBUS, set default
AAAAAAAAAAAAAAAAAAAA

PLEASE NOTE: This process changes to 19200 baud, even parity, ...
DIRECTIVE: Please don't forget to change the serial counterpart too!

Are you sure?

(Press "RETURN" to assume)
(Press "Esc" to cancel)

```

Press Enter

11. After completion the following message will be displayed:

```

=> Testmode finished!
=> DIRECTIVE: Please don't forget to change the serial counterpart too!

```

12. Enter X until you get back to the main menu. The Sommer Messtechnik device is now restarted and available for Modbus-communication. As the connection-parameters have been changed to Modbus, the connection to the sensor is lost. Press Disconnect for completion.

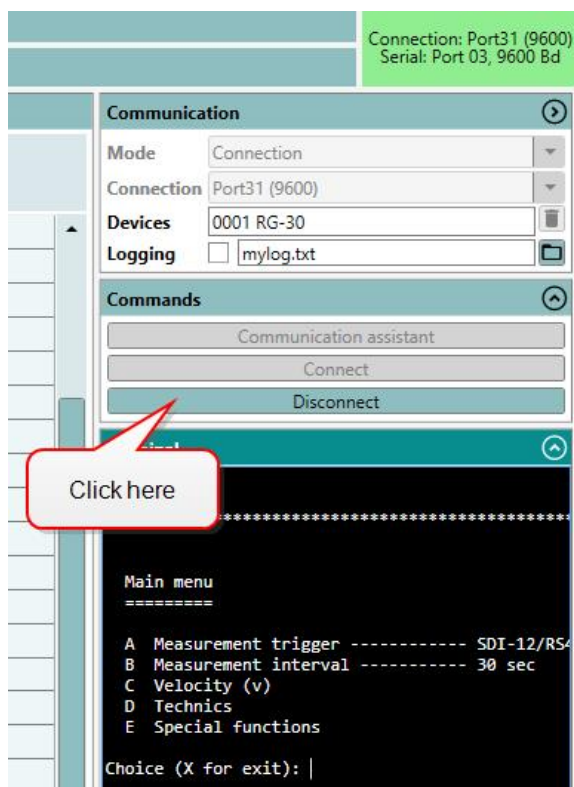
**NOTE**

By switching communication to Modbus with **MODBUS**, set default the following parameters are changed:

Parameter	Modbus setting
OP, measurement output	just per command
Output protocol (OP)	Modbus
MODBUS, device address	35
Sleep mode	Modbus, slow
Parity, stop bits	even par, 1 stop
Baud rate	19200
Flow control	off
Transmitter warm-up time	10 ms
Minimum response time	30 ms



TIP To change a parameter in the **Technics** menu you need to change your Commander-authorization to Expert. See [Change authorization](#) for instructions.

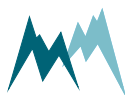

12.5.5 Modbus commands and registers

12.5.5.1 Read input registers

Input registers contain measurement values. The content of these registers is updated after each measurement.

	Index	Register address	Variable	Unit / value	Bytes	Format
Test value		0	Hardcoded test value	2.7519...	4	float
Main	01	2	Relay A	0 / 1	4	float
Main	02	4	Relay B	0 / 1	4	float
Main	03	6	Relay function	0 / 1	4	float
Main	04	8	Cube 5, ice	mm	4	float
Main	05	10	Cube 5, ice rate	mm/h	4	float
Main	06	12	Cube 5, temp	°C / F	4	float
Main	07	14	Rod 80, ice	mm	4	float
Main	08	16	Rod 80, ice rate	mm/h	4	float
Main	09	18	Rod 80, temp	°C / F	4	float
Special	10	20	Relay A, counter		4	float
Special	11	22	Relay A, time	h	4	float
Special	12	24	Relay B, counter		4	float
Special	13	26	Relay B, time	h	4	float
Special	14	28	Heating current	A	4	float
Special	15	30	Supply Voltage	V	4	float
Special	16	32	Exception code		4	float
Special	17	34	Cube 5, water	mm	4	float

	Index	Register address	Variable	Unit / value	Bytes	Format
Special	18	36	Rod 80, water	mm	4	float
Analysis	19	38	Cube 5, meas. ph		4	float
Analysis	20	40	Cube 5, ice raw	mm	4	float
Analysis	21	42	Cube 5, C P1 LF	pF	4	float
Analysis	22	44	Cube 5, C P1 HF	pF	4	float
Analysis	23	46	Cube 5, C P2 LF	pF	4	float
Analysis	24	48	Cube 5, C P2 HF	pF	4	float
Analysis	25	50	Cube 5, C P3 LF	pF	4	float
Analysis	26	52	Cube 5, C P3 HF	pF	4	float
Analysis	27	54	Cube 5, P P1 LF	°	4	float
Analysis	28	56	Cube 5, P P1 HF	°	4	float
Analysis	29	58	Cube 5, P P2 LF	°	4	float
Analysis	30	60	Cube 5, P P2 HF	°	4	float
Analysis	31	62	Cube 5, P P3 LF	°	4	float
Analysis	32	64	Cube 5, P P3 HF	°	4	float
Analysis	33	66	Rod 80, meas. ph		4	float
Analysis	34	68	Rod 80, ice raw	mm	4	float
Analysis	35	70	Rod 80, C P1 LF	pF	4	float
Analysis	36	72	Rod 80, C P1 HF	pF	4	float
Analysis	37	74	Rod 80, C P2 LF	pF	4	float
Analysis	38	76	Rod 80, C P2 HF	pF	4	float
Analysis	39	78	Rod 80, C P3 LF	pF	4	float
Analysis	40	80	Rod 80, C P3 HF	pF	4	float
Analysis	41	82	Rod 80, P P1 LF	°	4	float

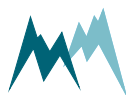

	Index	Register address	Variable	Unit / value	Bytes	Format
Analysis	42	84	Rod 80, P P1 HF	°	4	float
Analysis	43	86	Rod 80, P P2 LF	°	4	float
Analysis	44	88	Rod 80, P P2 HF	°	4	float
Analysis	45	90	Rod 80, P P3 LF	°	4	float
Analysis	46	92	Rod 80, P P3 HF	°	4	float
Device info	-	65533	Device type and configuration	320X	2	unsigned int
	-	65534	Software version	XYZZZ	2	unsigned int
	-	65535	Modbus implementation version	10100	2	unsigned int

Table 20 Input registers

**NOTE**

The 4-byte float values have the format *ABCD*, big-endian (*A* is the most significant byte).

Note the difference between float, double and decimal data types. While float is a 4-byte floating-point-number, double is a 8-byte and decimal a 16-byte floating-point number. Use the applicable conversion to obtain the correct measurement values!

12.5.5.2 Read and write holding registers

Holding registers are mainly used to configure the Modbus adapter communication. Configuration settings are read with function 03 (read holding registers) and written with function 06 (write single registers).



NOTE Restart the Modbus adapter after changing the configuration!

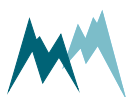

	Register address	Variable	Range	Bytes	Format
Config values	0	Modbus default ¹	0 - 1...read 1...write	2	unsigned int
	1	Modbus device address	1 to 247		
	2	RS-485 baud rate	1...1200 baud 2...2400 baud 3...4800 baud 4...9600 baud 5...19200 baud 6...38400 baud 7...57600 baud 8...115200 baud		
	3	RS-485 parity/ stop bits	1...no parity, 1 stop bit 2...no parity, 2 stop bits 3...even parity, 1 stop bit 4...odd parity, 1 stop bit		

Table 21 Holding registers

12.5.5.3 Report slave ID

The Modbus function 17 (report slave ID, read only) can be used to read basic information of the IDS-30cr. The following example shows the response of function 17 of a RG-30 sensor, which is received in hex-format:

 **EXAMPLE** 23 11 26 53 FF 27 74 20 53 6F 6D 6D 65 72 20
20 52 47 2D 33 30 20 20 20 32 5F 37 31 72 30 31 20 34
35 31 35 31 38 32 31 00 BB D4

¹Writing "1" sets the Modbus default settings.

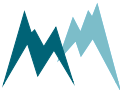

			Example	
	Content	Length (Bytes)	HEX-value	Decimal, ASCII
PDU* response	Slave address	1	23	35
	Function code	1	11	17
	Number of bytes (excl. slave-address, function code, NUL and CRC)	1	26	38
	Slave ID	1	53	"S"
	Run status (0=inactive; FF=active)	1	FF	255
	Modbus implementation version	2	27 74	10100
	Separator	1	20	" "
	Vendor string	7	53 6F 6D 6D 65 72 20	"Sommer "
	Separator	1	20	" "
	Device configuration	7	52 47 2D 33 30 20 20	"RG-30 "
	Separator	1	20	" "
	Software version	7	32 5F 37 31 72 30 31	2_71r01
	Separator	1	20	" "
	Serial number	8	34 35 31 35 31 38 32 31	45151821
	NUL	1	00	
	CRC	2	BB D4	

*Protocol Data Unit

Table 22 Slave ID

12.5.6 Reactivate Sommer Bus Protocol

Follow the instructions below to change the data output back to Sommer Bus Protocol:

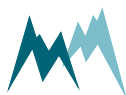

1. Open the **Connections (F8)** tab and click **New connection**.

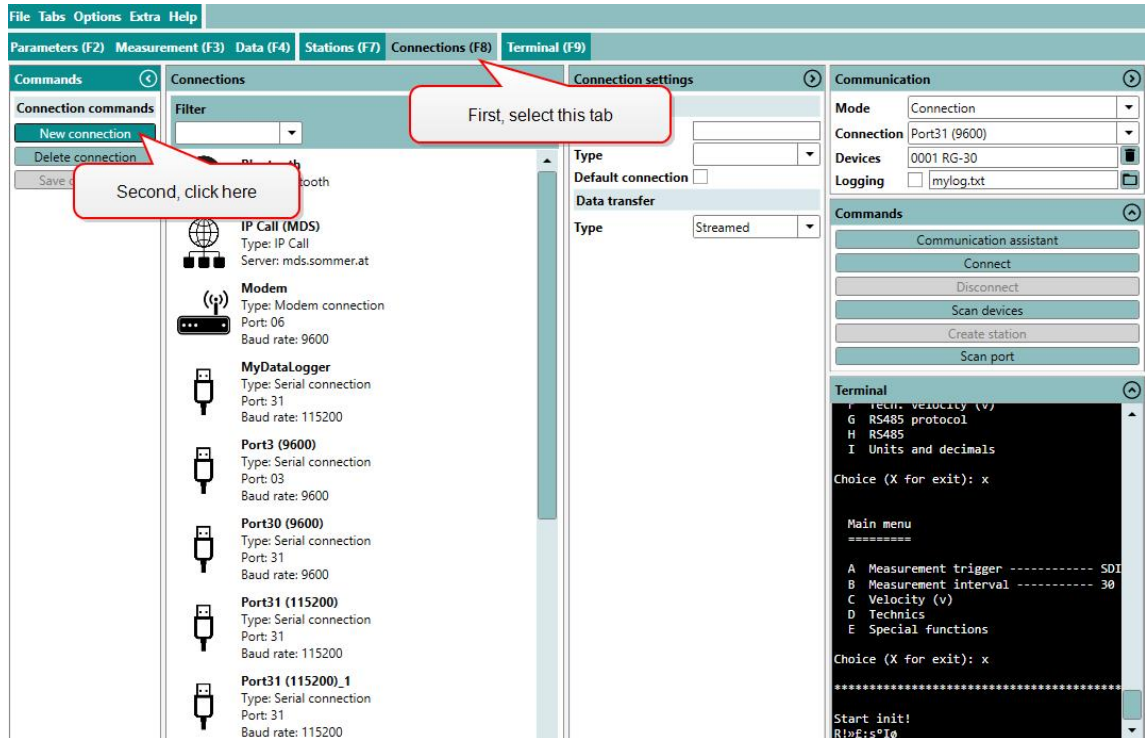

2. Enter the **Name** of the new connection. We recommend to use a meaningful name for later recognition, e.g. Modbus31 (19200) to indicate port 31 and Baud-rate 19200. Select the **Type** **Serial connection** and choose the **Port** your sensor is connected to, set the **Baud-rate** to **19200** and the **Parity/stop bits** to **Even par., 1 stop bit**.

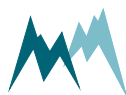

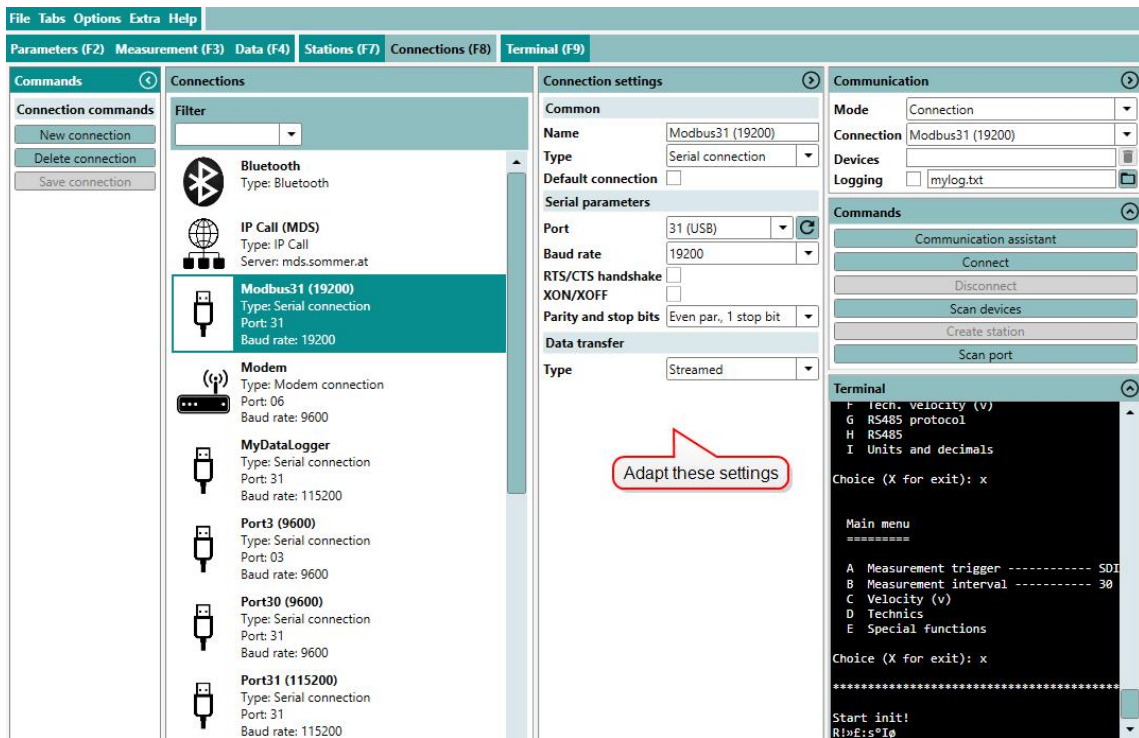

3. Click **Save connection**.
4. In the Communication window select **Mode Connection** and choose the **Connection** you have created. Then click **Connect**.

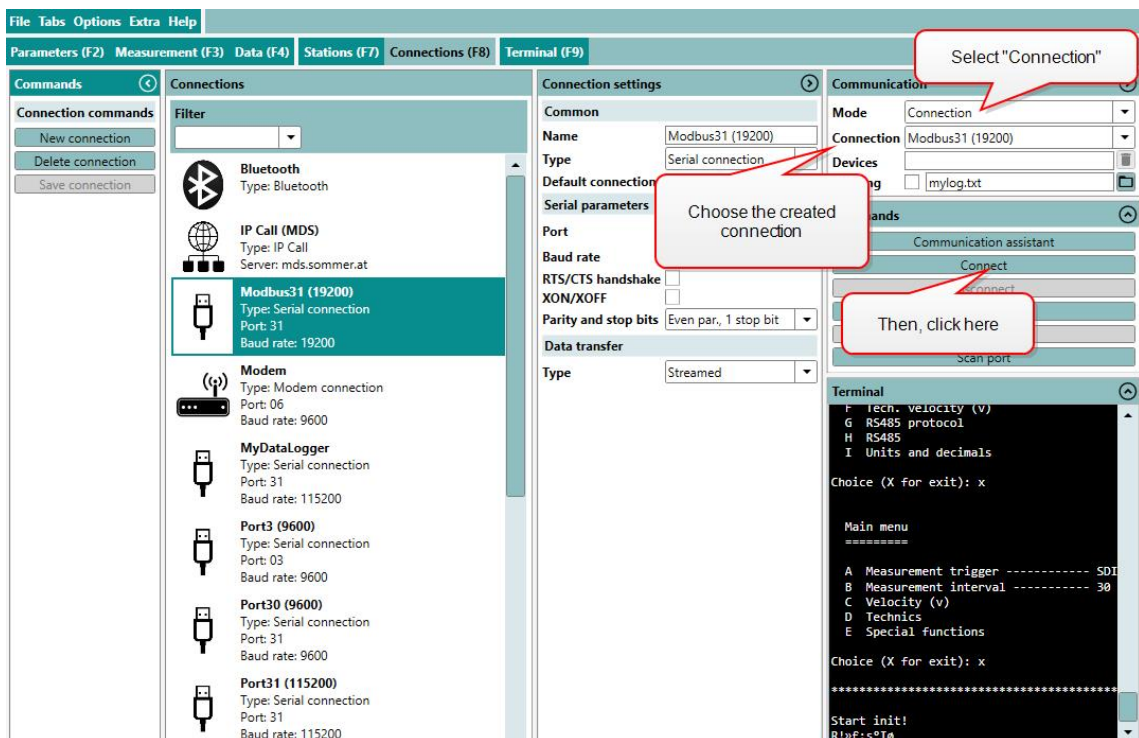

5. Download the parameters and save the parameter file as described in **Modbus configuration**.



TIP Save the parameter file for future use and to document configuration changes!

6. Now, two options are available to revert communication back to the Sommer Bus Protocol:
 - A. If a parameter file is available that has the Sommer Bus Protocol enabled, the file can be loaded by clicking **Open parameter file**, selecting the respective file and uploading the parameters to the device by clicking **Upload all parameters to device**.

The screenshot displays the software interface with the 'Parameters' tab selected. The 'File commands' section is highlighted, and two red callout boxes provide instructions: 'First, open the parameter file' pointing to the 'Open parameter file' button, and 'Second, upload parameters' pointing to the 'Upload all parameters to device' button. The 'Terminal' window shows a list of hex addresses and their corresponding parameter names, such as '#A0001 V:2_63r01 N:45151821 E:0x0000 P:1 t:R'.

- B. If no parameter file is available, the device has to be reset to its default configuration:



1. Click into the **Terminal** window and type ??? to enter the sensor-menu.

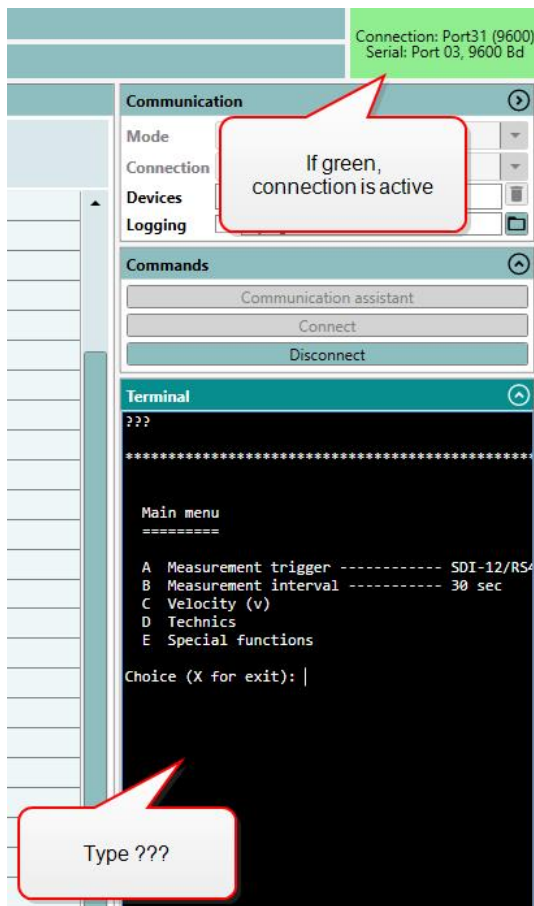

2. Navigate to **Special functions** and select **Set factory default...**
3. Acknowledge the safety-note.

```
Start up testmode: 0x07

Set factory default
^^^^^^^^^^^^^^^^^^^^

PLEASE NOTE: Please save all parameters before!
PLEASE NOTE: All user settings will be lost!
Are you sure?

(Press "RETURN" to assume)
(Press "Esc" to cancel)

=> Testmode finished!
```

4. Enter **X** until you get back to the main menu. The Sommer Messtechnik Sensor is now restarted and available in its initial configuration. As the connection-parameters have been changed to the default settings, the connection to the sensor is lost. Press **Disconnect** for completion.
7. Establish the original connection to the Sommer Messtechnik Sensor as described in **Modbus configuration**.

8. Download the sensor's parameters in the [Parameters \(F2\)](#) tab, adapt the required parameters, or upload your originally saved parameter file to the IDS-30cr.

12.5.7 PLC integration

The IDS-30cr can be integrated into a PLC system as a slave device. It supports the PROFIBUS, PROFINET, EtherCAT and CANopen protocols. This requires an additional serial converter, e.g. Anybus Communicator.

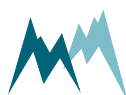

13 Parameter definitions

A	Relay A	98
B	Relay B	99
C	Sensor tests	101
D	Technics	102
E	Region format	120
F	Special functions	120

A Relay A

A-A	Output value	98
A-B	Sensor choice	98
A-C	Turn off delay	98
A-D	Ice limit	99
A-E	Ice rate limit	99
A-F	Melting limit	99
A-G	Test output	99

A-A Output value

Specifies the variable which controls the relay.

Option	Description
Off	Relay does not switch
Ice (default)	Relay is turned on if Output value exceeds specified value
Ice and ice rate	Relay is turned on if Output value and Output value exceed specified values
Water	Relay is turned on if Output value exceed specified value

A-B Sensor choice

The sensor for which the limit value is monitored.

A-C Turn off delay

The time relay is kept energized after the monitored variable falls below the limit value again.

Unit	sec	seconds



Value range	0...65535	600 (default)
--------------------	-----------	---------------

A-D Ice limit

The amount of ice accreted before the relay is switched.

Unit	mm	
Value range	0.0...9999999.9	0.5 (default)

A-E Ice rate limit

The rate at which ice accumulates before the relay is switched.

Unit	mm/h	
Value range	0...99999999	100 (default)

A-F Melting limit

The rate at which ice melts before the relay is switched.

Unit	mm/h	
Value range	0...99999999	100 (default)

A-G Test output

Function to test the relay manually.

B Relay B

B-A	Output value	100
B-B	Sensor choice	100
B-C	Turn off delay	100
B-D	Ice limit	100
B-E	Ice rate limit	100
B-F	Melting limit	101
B-G	Test output	101

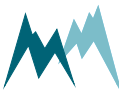

B-A Output value

Specifies the variable which controls the relay.

Option	Description
Off	Relay does not switch
Ice (default)	Relay is turned on if Output value exceeds specified value
Ice and ice rate	Relay is turned on if Output value and Output value exceed specified values
Water	Relay is turned on if Output value exceed specified value

B-B Sensor choice

The sensor for which the limit value is monitored.

B-C Turn off delay

The time relay is kept energized after the monitored variable falls below the limit value again.

Unit	sec	seconds
Value range	0...65535	600 (default)

B-D Ice limit

The amount of ice accreted before the relay is switched.

Unit	mm	
Value range	0.0...9999999.9	0.5 (default)

B-E Ice rate limit

The rate at which ice accumulates before the relay is switched.

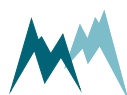

Unit	mm/h	
Value range	0...999999999	100 (default)

B-F Melting limit

The rate at which ice melts before the relay is switched.

Unit	mm/h	
Value range	0...999999999	100 (default)

B-G Test output

Function to test the relay manually.

C Sensor tests

C-A	Cube 5, test heating	101
C-B	Cube 5, test	101
C-C	Rod 80, test	101

C-A Cube 5, test heating

Function to test the sensor heating. Heats the sensor for the selected duration.

C-B Cube 5, test

Function to test the ice-sensor. Returns the currently measured capacity values. Used to verify that the sensor reads zero when dry.

C-C Rod 80, test

Function to test the ice-sensor. Returns the currently measured capacity values. Used to verify that the sensor reads zero when dry.

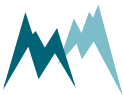

D Technics

D-A	SDI-12 address	102
D-B	Measurement Interval	102
D-C	Units and decimals	102
D-D	SBP device addressing	103
D-E	RS-485 (COM)	104
D-F	Cube 5 sensor	109
D-G	Rod 80 sensor	115
D-H	Advanced settings	117
D-I	Measurement table	119

D-A SDI-12 address

`generic-sdi-12-address`

The address is a unique identifier of the sensor within a SDI-12 bus system.

Value range	Default	Units
0...9, a...z, A...Z	0	-

D-B Measurement Interval

`generic-measurement-interval`

The interval at which measurements are acquired.

Value range	Default	Units
20...18'000	60	s

D-C Units and decimals

D-C-A	Temperature, unit	102
D-C-B	Temperature, decimals	103

D-C-A Temperature, unit

`generic-units-temperature`

The following units of the air temperature can be selected:

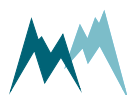

ID	Option	Description
1	°C (default)	Degrees Celsius
2	°F	Fahrenheit

D-C-B Temperature, decimals

`generic-decimals-temperature`

The number of decimal places for the measured air temperature.

Value range	Default	Units
0...6	2	-

D-D SBP device addressing

D-D-A	Device number	103
D-D-B	System key	103

D-D-A Device number

`generic-rs-485-protocol-device-number`

The device number is used for the unique identification of the device in a bus system.

Value range	Default	Units
0...98	1 (default)	-

D-D-B System key

`generic-rs-485-protocol-system-key`

The system key defines the bus system of the device. Thus, different conceptual bus systems can be separated. Interfering bus systems occur if the remote radio coverage of two measurement systems overlap. In general, the system key should be set to 00.

Value range	Default	Units
0...99	0	-

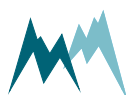

D-E RS-485 (COM)

D-E-A	Output protocol	104
D-E-A-A	Output protocol (OP)	104
D-E-A-B	Measurement output	105
D-E-A-C	Information	105
D-E-A-D	Wake-up sequence	105
D-E-A-E	Prefix holdback	106
D-E-A-F	MODBUS, set default	106
D-E-A-G	MODBUS, device address	106
D-E-B	Port	106
D-E-B-A	Baudrate	107
D-E-B-B	Parity, stop bits	107
D-E-B-C	Minimum response time	107
D-E-B-D	Transmitter warm-up time	108
D-E-B-E	Flow control	108
D-E-B-F	Sending window	108
D-E-B-G	Receiving window	108

D-E-A Output protocol

D-E-A-A	Output protocol (OP)	104
D-E-A-B	Measurement output	105
D-E-A-C	Information	105
D-E-A-D	Wake-up sequence	105
D-E-A-E	Prefix holdback	106
D-E-A-F	MODBUS, set default	106
D-E-A-G	MODBUS, device address	106

D-E-A-A Output protocol (OP)

`generic-rs-485-protocol-output-protocol`

The type of the serial output protocol. The following options are available:

ID	Option	Description
1	Sommer (SBP) (default)	Sommer Bus Protocol; data values are returned with an index starting at 1. Multiple strings may be returned.
2	Standard	Standard protocol; data values are returned without an index in one string.
3	MODBUS	Modbus protocol



NOTE For MODBUS applications run `MODBUS, set default` to get the appropriate communication settings.

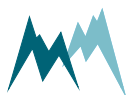

D-E-A-B Measurement output

generic-rs-485-protocol-measurement-output

Specifies the timing of the serial data output.

ID	Option	Description
1	Just per command	The output is only requested by commands via RS-485.
2	After measurement (default)	The serial data output is performed automatically right after each measurement.
3	Pos. TRIG slope	The output is triggered by a positive edge of a control signal applied to the trigger input.

D-E-A-C Information

generic-rs-485-protocol-information

The main measurement values are always included in the data output string. Additionally, special and analysis values can be included.

ID	Option	Description
1	Main values	Only the main values are returned.
2	& Special values (default)	Main values and special values are returned.
3	& Analysis values	Main, special and analysis values are returned.

D-E-A-D Wake-up sequence

generic-rs-485-protocol-wake-up-sequence

Serial data can be transmitted to a recording device automatically without a request. However, many devices demand a wake-up sequence before they can receive and process data. The IDS-30cr has the option to send a sync sequence and a prefix before data are transmitted. The following options are available:

ID	Option	Description
1	Off	No wake-up sequence
2	Sync	The sync sequence UU~?~? is sent before the output string.
3	Prefix (default)	A blank with a time delay is sent before the output string.
4	Prefix & Sync	A blank with a time delay and the sync sequence UU~?~? is sent before the output string.

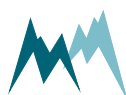

D-E-A-E Prefix holdback`generic-rs-485-protocol-prefix-holdback`

The hold-back time defines the time delay between the prefix and the data string.

Value range	Default	Units
0...5'000	300	ms

D-E-A-F MODBUS, set default`generic-rs-485-protocol-modbus-set-default`

Sets all parameters required for Modbus communication automatically. The following settings are adapted:

Parameter	Modbus setting
OP, measurement output	just per command
Output protocol (OP)	Modbus
MODBUS, device address	35
Sleep mode	Modbus, slow
Parity, stop bits	even par, 1 stop
Baud rate	19200
Flow control	off
Transmitter warm-up time	10 ms
Minimum response time	30 ms

D-E-A-G MODBUS, device address`generic-rs-485-protocol-modbus-device-address`

Unique device address for the Modbus protocol.

Value range	Default	Units
1...247	35	-

D-E-B Port

D-E-B-A	Baudrate	107
D-E-B-B	Parity, stop bits	107
D-E-B-C	Minimum response time	107
D-E-B-D	Transmitter warm-up time	108
D-E-B-E	Flow control	108
D-E-B-F	Sending window	108
D-E-B-G	Receiving window	108

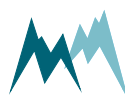

D-E-B-A Baudrate

generic-rs-485-port-baud-rate

The following transmission rates in bps (baud) can be selected:

ID	Option	Description
1	1'200	-
2	2'400	-
3	4'800	-
4	9'600 (default for sensors and data logger inputs)	-
5	19'200 (default if used with radio communication)	-
6	38'400	-
7	57'600	-
8	115'200 (default for data loggers)	-

D-E-B-B Parity, stop bits

generic-rs-485-port-parity-stop-bits

The following combinations of parity and stop bits can be selected:

ID	Option	Description
1	No par, 1 stop (default)	No parity and 1 stop bit
2	No par, 2 stop	No parity and 2 stop bits
3	Even par, 1 stop	Even parity and 1 stop bit
4	Odd par, 1 stop	Odd parity and 1 stop bit

D-E-B-C Minimum response time

generic-rs-485-port-minimum-response-time

This setting avoids failures of half-duplex interfaces. For this purpose the response to a command is delayed by the selected time. Additionally, the response is also kept temporally compact.

Value range	Default	Units
0...2'000	10	ms

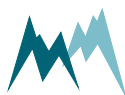

D-E-B-D Transmitter warm-up time`generic-rs-485-port-transmitter-warm-up-time`

The transmitter warm-up time defines the time before data is sent.

Value range	Default	Units
0...2'000	10	ms

D-E-B-E Flow control`generic-rs-485-port-flow-control`

Flow control for the defined application.

ID	Option	Description
1	Off	no flow control
2	XOFF-XON blocking (default)	XOFF-XON flow control, especially adapted for half-duplex systems
4	DFM-RC	Flowcontrol for Sommer Messtechnik DFM point-to-point radios.
5	DFM-TM	Flowcontrol for Sommer Messtechnik DFM tiny-mesh radios.

D-E-B-F Sending window`generic-rs-485-port-sending-window`

If XON-XOFF flow control is activated data are transmitted in blocks with the defined length.

Value range	Default	Units
200...5'000	300	ms

D-E-B-G Receiving window`generic-rs-485-port-receiving-window`

If XON-XOFF flow control is activated transmission of blocks is delayed by the specified time.

Value range	Default	Units
200...5'000	300	ms

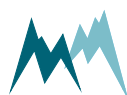

D-F Cube 5 sensor

D-F-A	Icing verification	109
D-F-B	Limits and timer	110
D-F-C	Cube 5 temperature	114
D-F-D	Cube 5, test heating	115
D-F-E	Cube 5, zero adjust	115
D-F-F	Cube 5, test	115

D-F-A Icing verification

D-F-A-A	Maximum temperature	109
D-F-A-B	Maximum water	109
D-F-A-C	Switch on delay	109

D-F-A-A Maximum temperature

Temperature below which icing may occur.

Unit	°C	
Value range	-99999.9...999999.9	0.5 (default)

D-F-A-B Maximum water

Thickness of water layer below which icing may occur.

Unit	mm	
Value range	0.0...9999999.9	0.5 (default)

D-F-A-C Switch on delay

Time delay between verification of icing and actual output of icing in data string. Specifying a delay might be advisable under threshold conditions.

Unit	sec	
Value range	0...7200	0 (default)

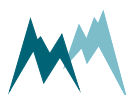

D-F-B Limits and timer

D-F-B-A	Min. sup. voltage for heating	110
D-F-B-B	Ice, maximum	110
D-F-B-C	Ice, minimum	110
D-F-B-D	Water, maximum	110
D-F-B-E	Water, minimum	111
D-F-B-F	Ice rate, heating	111
D-F-B-G	Ice rate, minimum	112
D-F-B-H	Ice rate, holdtime	112
D-F-B-I	Maximum heating time	113
D-F-B-J	Subsequent heating, head	113
D-F-B-K	Subsequent heating, shaft	113
D-F-B-L	Cool down duration	113
D-F-B-M	Duration frost suppression	114
D-F-B-N	Meas. duration icing rate	114

D-F-B-A Min. sup. voltage for heating

Minimum supply voltage for sensor heating.

Unit	V	
Value range	0.00...999999.99	10 (default)

D-F-B-B Ice, maximum

Maximum ice accumulation before sensor starts heating.

Unit	mm	
Value range	0...9999999.9	1 (default)

D-F-B-C Ice, minimum

Thickness of ice layer at which heating stops. This limit is only active in combination with [Water, minimum](#).

Unit	mm	
Value range	0...9999999.9	0.1 (default)

D-F-B-D Water, maximum

Maximum water accumulation before sensor starts heating.



Unit	mm	
Value range	1.0...9999999.9	2 (default)

D-F-B-E Water, minimum

Thickness of water layer at which heating stops. This limit is only active in combination with [Ice, minimum](#).

Unit	mm	
Value range	0.0...9999999.9	0.1 (default)

D-F-B-F Ice rate, heating

A switch to activate a sensor heating if the icing-rate drops below a specified limit. Generally, this option is used to detect individual icing-events.

If ice accumulates on the sensor above a limit value specified in [Ice limit](#), relay A and/or B close; see [Figure 6](#) for an illustration. Ice accretion may continue above this limit value, but may eventually cease, i.e. the icing rate levels off. Any further accumulation on the existing ice layer can be detected with reduced sensitivity only. Thus, it would be advantageous to continue ice-monitoring with a dry sensor surface. The “ice rate, heating” setting enables this option: If the icing rate falls below the value specified in [Ice rate, minimum](#) over the time set in [Ice rate, holdtime](#) a sensor heating is triggered. Consequently, relay A and/or B open, the sensor is defrosted and the IDS-30cr is ready to detect a new icing event.

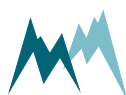

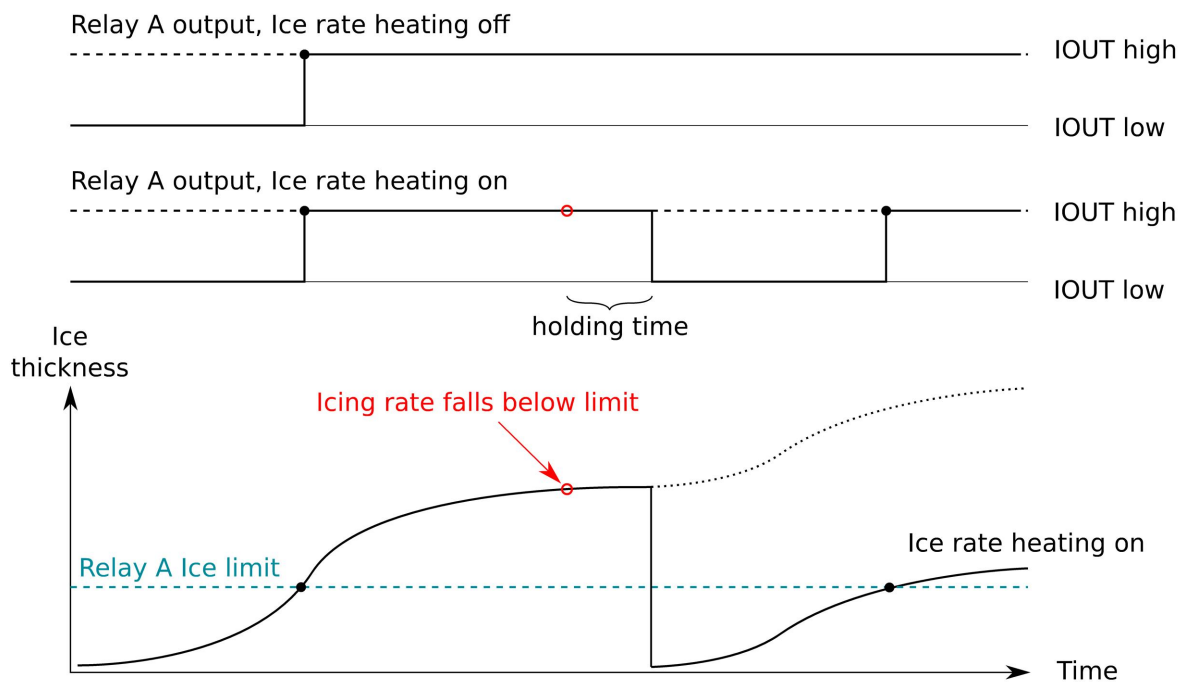

Figure 6 Behavior of Ice rate heating option

Option	Description
off	Sensor heating triggered by reduced icing rate is inactive.
on (default)	Sensor heating triggered by reduced icing rate active.

D-F-B-G Ice rate, minimum

Minimum icing rate below which a sensor heating is triggered. See [Ice rate, heating](#) for details.

Unit	mm/h	
Value range	-999999.9...9999999.9	0.5 (default)

D-F-B-H Ice rate, holdtime

Time before a sensor heating is triggered due to a low icing rate. See [Ice rate, heating](#) for details.

Unit	sec	
Value range	0...7200	600 (default)

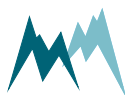

D-F-B-I Maximum heating time

Maximum heating duration for one heating cycle.

Unit	sec	
Value range	0...7200	600 (default)

D-F-B-J Subsequent heating, head

The time the sensor head is continued to be heated after a regular heating cycle.

Unit	sec	
Value range	0...1800	0 (default)

D-F-B-K Subsequent heating, shaft

The time the sensor shaft heating is active after a regular heating cycle. If set to *-1* shaft heating is deactivated.

This setting allows additional heating of the shaft, after the minimum values for ice and water have been reached with regular heating.

**NOTE**

Deactivating shaft heating reduces power consumption of the IDS-30cr to max. 2 A.

Unit	sec	
Value range	0...1800	120 (default) -1 (heating deactivated)

D-F-B-L Cool down duration

Time for sensor to cool down to ambient conditions.

Unit	sec	
Value range	0...1800	180 (default)

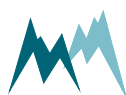

D-F-B-M Duration frost suppression

Frost generally builds up to thin ice layers well below the **Ice, minimum** limit and the relay **Duration frost suppression** before accretion levels off. To detect individual frost events a sensor heating can be triggered after a specified time with no further ice accumulation. The sensor surface is then dry again to sense the next frost-event. **Figure 7** illustrates such a situation:

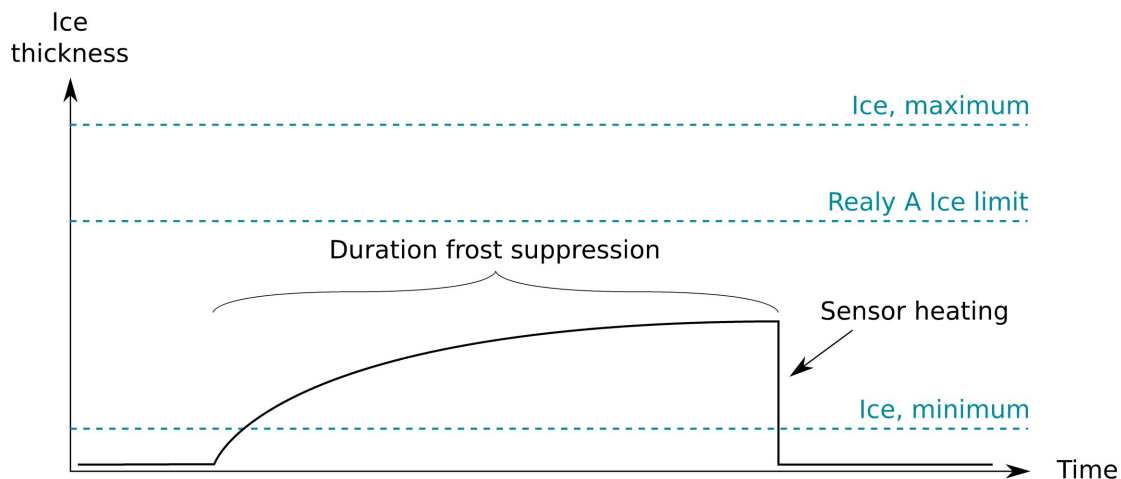



Figure 7 Duration frost suppression

 **ATTENTION** If **Duration frost suppression** is set to 0 frost suppression is inactive.

Unit	sec	
Value range	-86400...86400	0 (default)

D-F-B-N Meas. duration icing rate

Measurement time used to determine icing rate.

Unit	sec	
Value range	0...1800	360 (default)

D-F-C Cube 5 temperature

D-F-C-A Temperature offset 115

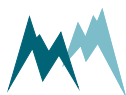

D-F-C-B	Adjust temperature	115
D-F-C-C	Test temperature	115

D-F-C-A Temperature offset

Offset of the temperature of the T/rH-sensor. An offset might be required if the sensor needs to be matched to an external reference.

Unit	°C	
Value range	-9999.99...99999.99	0 (default)

D-F-C-B Adjust temperature

Function to adjust the temperature measurement of the T/rH-sensor. Applying this function will update the setting [Temperature offset](#).

D-F-C-C Test temperature

Function to test the temperature measurement of the T/rH-sensor.

D-F-D Cube 5, test heating

Function to test the sensor heating. Heats the sensor for the selected duration.

D-F-E Cube 5, zero adjust

Function to reset the capacity measurements of the sensor plates. Only used during installation to compensate for any capacities introduced by the sensor cable.

D-F-F Cube 5, test

Function to test the ice-sensor. Returns the currently measured capacity values. Used to verify that the sensor reads zero when dry.

D-G Rod 80 sensor

D-G-B	Icing verification	116
D-G-C	Rod 80 temperature	116
D-G-D	Rod 80, zero adjust	117
D-G-E	Rod 80, test	117

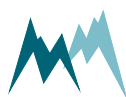

13.4.7.1 Meas. duration icing rate

Delete this text and replace it with your own content.

D-G-B Icing verification

D-G-B-A	Maximum temperature	116
D-G-B-B	Maximum water	116
D-G-B-C	Switch on delay	116

D-G-B-A Maximum temperature

Temperature below which icing may occur.

Unit	°C	
Value range	-99999.9...999999.9	0.5 (default)

D-G-B-B Maximum water

Thickness of water layer below which icing may occur.

Unit	mm	
Value range	0.0...9999999.9	0.5 (default)

D-G-B-C Switch on delay

Time delay between verification of icing and actual output of icing in data string. Specifying a delay might be advisable under threshold conditions.

Unit	sec	
Value range	0...7200	0 (default)

D-G-C Rod 80 temperature

D-G-C-A	Temperature offset	117
D-G-C-B	Adjust temperature	117
D-G-C-C	Test temperature	117

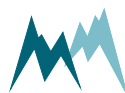

D-G-C-A Temperature offset

Offset of the temperature of the T/rH-sensor. An offset might be required if the sensor needs to be matched to an external reference.

Unit	°C	
Value range	-9999.99...99999.99	0 (default)

D-G-C-B Adjust temperature

Function to adjust the temperature measurement of the T/rH-sensor. Applying this function will update the setting [Temperature offset](#).

D-G-C-C Test temperature

Function to test the temperature measurement of the T/rH-sensor.

D-G-D Rod 80, zero adjust

Function to reset the capacity measurements of the sensor plates. Only used during installation to compensate for any capacities introduced by the sensor.

D-G-E Rod 80, test

Function to test the ice-sensor. Returns the currently measured capacity values. Used to verify that the sensor reads zero when dry.

D-H Advanced settings

D-H-A	Sleep mode	117
D-H-B	SDI12 'M'-response	118
D-H-C	Functional switch monitoring	118
D-H-D	Sommer ID	119

D-H-A Sleep mode

`generic-sleep-mode`

Defines the behavior of the IDS-30cr between two measurements, provided the measurement interval is longer than the time of the measurement itself. The following options are available:

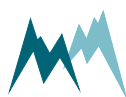

ID	Option	Description
1	MODBUS, fast	For MODBUS applications. The IDS-30cr stays in normal mode. This option permits high data transmission rates, but increases power consumption.
2	MODBUS, slow	For MODBUS applications. The IDS-30cr goes into idle mode and can be woken up by a command via the RS-485 interface with a low baud rate. This option reduces power consumption at lower data transmission rates.
3	Standard (default)	The IDS-30cr goes into sleep mode and can be woken up by a command via the RS-485 interface only with a time delay. Option with the lowest power consumption.

D-H-B SDI12 'M'-response

`generic-sdi-12-m-response`

Defines how an SDI-12 M-command received by the IDS-30cr is answered if the requested number of measurement values exceeds 9. The following options are available:

ID	Parameter	Description
1	expand address	This option should only be used with SDI-12 standard V1.0. The measurement values can be requested with the commands <code>aD0!</code> , <code>aD1!</code> , ..., with <code>a</code> the sensor address. Max. 9 values are returned for each command.
2	just expand output	The M-request received by the IDS-30cr is answered according to SDI-12 standard V1.3, which supports transmitting more than 9 measurement values per answer.
3	as at 'C' request	The M-request received by the IDS-30cr is answered as if several C-requests were sent.
4	M1, M2, M3 split (default)	The M-request received by the IDS-30cr is answered as if several M _k -commands were sent, with <code>k</code> depending on the number of measurement values to be transmitted (M1 returns the first 9 measurement values, M2 the second nine values, etc).

D-H-C Functional switch monitoring

Sets the activity of the "OUT function" output. The following options are available:

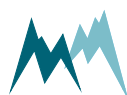

Option	Description
just while awake	The “OUT function” output is only active while the device is active.
always active (default)	The “OUT function” output is always active.



ATTENTION If **Functional switch monitoring** is set to *just while awake*, **Sleep mode** must be set to *standard*!

D-H-D Sommer ID

generic-sommer-id

The Sommer ID is used to define stations within the Commander software. The ID is preset in the device and corresponds to its serial number. SOMMER suggests not to change the ID, except if a IDS-30cr device is replaced. In such a case it can be practical to change the ID of the new device to the ID of the replaced device to guarantee data consistency.

D-I Measurement table

Lists all measured variables with their units (see [Data output](#)).

Index	Value	Unit	Description
01	Relay A	0 / 1	State of relay A
02	Relay B	0 / 1	State of relay B
03	Relay function	0 / 1	State of measurement device
04	Cube 5, ice	mm	Current ice layer thickness on Cube 5 sensor
05	Cube 5, ice rate	mm/h	Current icing rate on Cube 5 sensor
06	Cube 5, temp	°C / F	Surface temperature of Cube 5 sensor
07	Rod 80, ice	mm	Current ice layer thickness on Rod 80 sensor
08	Rod 80, ice rate	mm/h	Current icing rate on Rod 80 sensor
09	Rod 80, temp	°C / F	Surface temperature of Rod 80 sensor

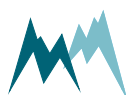

E Region format

E-A	Language/Sprache	120
E-B	Decimal character	120

E-A Language/Sprache

`generic-language`

The menu language.

ID	Option	Description
1	German/Deutsch	German language
2	English/Englisch (default)	English language

E-B Decimal character

`generic-decimals-character`

The character used as decimal separator in the values of the settings, in serial data strings and in .csv files.

ID	Option	Description
1	Comma	-
2	Dot (default)	-

F Special functions

F-A	Relay, reset counters	121
F-B	Relay, simulate outputs	121
F-C	Device status	121
F-D	View setup	121
F-E	Set factory default	121
F-F	Temp. load factory default	121
F-G	Relaunch program	122



F-A Relay, reset counters

Resets the relay counters.

F-B Relay, simulate outputs

Only available in terminal mode. This function is primarily used for remote system testing and can be triggered by the test input on pin 5 (see for details). It offers two options:

1. If option *1* is selected or the trigger signal on pin 5 is set high the following tasks are performed in sequence:
 - a. Relay A is closed and the sensor heating (head and shaft) is turned on for 60 sec (if sensor 1 is active)
 - b. Relay B is closed and the sensor heating (head and shaft) is turned on for 60 sec (if sensor 2 is active)
2. If option *2* is selected or the trigger signal on pin 5 is set high for more than 10 sec the tasks in option *1* are performed and the relay counters are reset.

F-C Device status

```
generic-special-functions-device-status
```

Displays information about the device and the software version.

F-D View setup

```
generic-special-functions-view-setup
```

All parameters of the IDS-30cr are listed in the terminal window.

F-E Set factory default

```
generic-special-functions-set-factory-default
```

All parameters are reset to factory defaults. Only available in terminal-mode.

F-F Temp. load factory default

```
generic-special-functions-temp-load-factory-default
```

Loads factory default values temporarily. Only available in terminal mode.

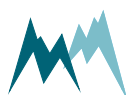

F-G Relaunch program

`generic-special-functions-relaunch-program`

The device is restarted. Powering the device off and on again is equivalent.

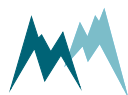

Appendix A Measurement phases

The measurement phase describes the status of the IDS-30cr sensors. It is returned with the analysis values at indices 26 and 40 and has the following format:

AA.C

The labels are coded as follows:

Label	Description
AA	Sensor status, see Sensor status
C	Icing verification result of sensor 1, see Icing verification results



EXAMPLE

4.00 Cube 5 sensor is heating
Icing-criteria for both sensors are satisfied

2.04 Cube 5 sensor is cooling down
Icing-criteria of Rod T 80 sensor are satisfied
Temperature of Cube 5 sensor is too high

A.1 Sensor status

The sensor status `AA` can take the values listed in [Sensor status](#).

A.2 Icing verification

The IDS-30cr uses the prevailing environmental conditions to verify the icing measured by the ice-sensors. Ice can only accrete on a sensor surface if the following conditions are satisfied:

- The sensor surface temperature must be below the limit specified in [Maximum temperature](#).
- The water content on the sensor surface must be below the limit value specified in [Maximum water](#).

The icing verification values `B` and `C` can take the values listed in [Icing verification results](#).

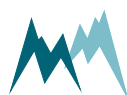

Value	Description	Comment
-1	Measurements are off	Above a specified ambient temperature the IDS-30cr does not perform any icing-measurements.
0	Measurement active	Normal measurement mode
1	Determination of icing rate	Determines icing rate after cool down
2	Cool down, waiting time	After a heating cycle the sensor cools down to ambient temperature.
3	Subsequent heating	Sensor is heated after heating phase 4, 5 or 6 to ensure that the surface is completely dry.
4	Heating triggered by Ice, maximum	Sensor exceeds Ice, maximum value. Heating is on until ice and water layer thickness fall below Ice, minimum and Water, minimum or Maximum heating time has elapsed.
5	Heating triggered by Water, maximum	Sensor exceeds Water, maximum value. Heating is on until ice and water layer thickness fall below Ice, minimum and Water, minimum or Maximum heating time has elapsed.
6	Heating triggered by Ice rate, minimum	Icing rate falls below Ice rate, minimum . Heating is on until ice and water layer thickness fall below Ice, minimum and Water, minimum or Maximum heating time has elapsed.
14	Heating triggered by frost suppression, ice	Sensor exceeds Ice, minimum , stays below Ice limit of relay A or B and exceeds time limit of Duration frost suppression . Heating is on until ice and water layer thickness fall below Ice, minimum and Water, minimum or Maximum heating time has elapsed.

Sensor status

Value	Description
0	all icing-criteria are satisfied
1	water content too high
4	sensor temperature too high
5	water content too high
8	Switch on delay elapses

Icing verification results

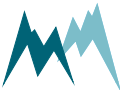

Appendix B Troubleshooting

B.1	Devices	125
B.1.1	The IDS-30cr is not responding or returns unreadable characters	125
B.1.2	The IDS-30cr reboots repeatedly	127
B.2	Measurement data	127
B.2.1	Measurement data are not updated	127
B.2.2	Heating current returns -0.02 A or 99999997.	127
B.3	Firmware & software	128
B.3.1	Commander loads wrong setup	128
B.3.2	Firmware update via RS-485 is aborted	128
B.4	RS-485	128
B.4.1	Configuration via terminal shows unexpected behavior	128
B.5	SDI-12	129
B.5.1	The IDS-30cr is not detected by a SDI-12 master device	129
B.5.2	Data logger receives no SDI-12 data	129
B.6	Modbus	129
B.6.1	Modbus function 04 returns obscure measurement values	129

B.1 Devices

B.1.1 The IDS-30cr is not responding or returns unreadable characters

Reason	Solution
The power supply is not connected or turned off.	Check if the power supply is connected and on.
The polarity of connected power supply wires is wrong.	Check the polarity of connected wires.
Wrong sensor cable.	Use the original sensor cable configured by Sommer Messtechnik (only applicable to Sommer Messtechnik cables).
Power supply is insufficient. The IDS-30cr requires a certain inrush-current that the power supply is not able to provide.	<ol style="list-style-type: none"> 1. Use a power supply providing >0.5 A at 12 VDC or a fully charged battery. 2. In case of long sensor cables (>50 m) use a 24-VDC power supply. Please note that power supplied by the USB-port is insufficient to power the IDS-30cr!
The power supply voltage is out of range.	Adjust the power supply to match the specified voltage range.

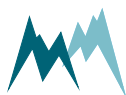

Reason	Solution
The polarity of the connected RS-485-A and RS-485-B wires is wrong.	Reverse the polarity of the connected RS-485-A and RS-485-B wires.
The port settings of the IDS-30cr and the data acquisition system do not match.	Use the Commander Communication assistant or adapt port settings on your device.  NOTE Sommer Messtechnik devices require the following Baud rates: <ul style="list-style-type: none"> ■ Sensor: 9600 ■ Data logger: 115200 ■ Modbus: 19200 In case of doubt use the function Check port in the Communication assistant .
The IDS-30cr is set to Modbus.	Connect to the sensor using the Communication assistant of the Commander and select the Modbus option in the Serial connection .
A sensor wire is not connected firmly to the terminal of the data acquisition device.	Check the firm connection of the sensor wires.
IDS-30cr and data acquisition device have different grounds.	Connect the grounds of the IDS-30cr and the data acquisition device.
A pin of the connector plug is bent or broken.	Verify that all connector pins are straight.
The sensor cable is damaged.	Replace the sensor cable.
The COM-port has not been assigned correctly to the USB converter.	<ol style="list-style-type: none"> 1. Make sure to use a Sommer Messtechnik USB converter. Third party converters are not supported. 2. Check the COM-port number using Windows Device Manager. 3. Plug in the USB converter first, then start Commander.
The USB converter is faulty.	Replace the USB converter.
The USB port on your PC is not working.	Use another USB port.
The driver of the USB converter was incorrectly installed	Reinstall the driver of the USB converter.

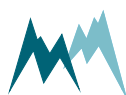

B.1.2 The IDS-30cr reboots repeatedly

Reason	Solution
The power supply has not enough current to start the IDS-30cr.	Verify that the power supply provides enough current. A IDS-30cr consumes up to 140 mA @ 12 V. If required, power the IDS-30cr by an additional or alternative supply.

B.2 Measurement data

B.2.1 Measurement data are not updated

The device is connected to the Commander, but the data are not updated.

Reason	Solution
Data traffic conflict	Reboot the device by interrupting the power supply.

B.2.2 Heating current returns -0.02 A or 99999997.

Cause	Solution
The sensor temperature is too high (>20 °C). If the conditions that trigger a sensor heating are met, but the sensor is too warm, the IDS-30cr returns -0.02 A (or 99999997 in older IDS-30cr versions).	Generally, this behavior only occurs under higher ambient temperatures, e.g. during sensor tests in the laboratory. The specified limit of 20 °C may be changed by Sommer Messtechnik (Wartungsmenü > Heizung, Sicherheitsstop).
One of the heater switches is broken (indicated by value 99999997).	Return controller to Sommer Messtechnik for repair.

B.3 Firmware & software

B.3.1 Commander loads wrong setup

If the setup is reloaded from the device the Commander seems to display an old version.

Cause	Solution
The device has been connected to the same PC before and several different setup files have been loaded.	<ul style="list-style-type: none"> In the Communication section of the Commander, select Mode Connection and click on the trash can icon on the right edge. Then, reload the setup from the device. Delete the setup files of the device that have been downloaded by Commander to the folder <code>C:\Users\Public\Documents\Sommer\Setup</code>. The respective files can be identified by the serial number in the file name and the file date.

B.3.2 Firmware update via RS-485 is aborted

Reason	Solution
USB to RS-485 converter cable is damaged or can only operate on 9600 baud.	Replace USB to RS-485 converter cable. The programmer requires 57600 baud.

B.4 RS-485

B.4.1 Configuration via terminal shows unexpected behavior

Accessing the parameter menus in the terminal leads to unexpected behavior, e.g. after entering a menu character the terminal displays repeated error messages or jumps out of the parameter menu.

Reason	Solution
The sensor, power supply and PC/laptop do not share the same ground.	Verify that all equipment is connected to the same ground.

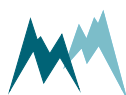

B.5 SDI-12

B.5.1 The IDS-30cr is not detected by a SDI-12 master device

Reason	Solution
The IDS-30cr and the SDI-12 master have different grounds.	Verify that the IDS-30cr and the SDI-12 master are connected by a ground (GND) wire.

B.5.2 Data logger receives no SDI-12 data

Reason	Solution
The sensor is set to <i>Measurement trigger interval</i> , but the data logger sends a M! command, i.e. the data logger polls data.	If data are polled from the sensor, <i>Measurement interval</i> must be set to <i>SDI-12/RS485</i> .
The sensor is set to <i>Measurement trigger SDI-12/RS485</i> , but the data logger sends an R! command, i.e. the sensor pushes data.	If the sensor pushes data, <i>Measurement interval</i> must be set to <i>interval</i> .

B.6 Modbus

B.6.1 Modbus function 04 returns obscure measurement values

Reason	Solution
Sensor does not run in its own measurement interval, i.e., <i>MeasuremenSet Mt trigger</i> is not set to <i>Interval</i> .	Set <i>Measurement trigger</i> of the sensor to <i>Interval</i> . A Modbus master can only read measurement data, it cannot trigger measurements.
A second Modbus master is present in the RS-485 bus.	Make sure that only one Modbus master is communicating with the Modbus slaves.
Port settings of Modbus master and slave do not match.	Verify that port settings of Modbus master and slave match. Generally, the port settings are 19200, even par, 1 stop, no flow control.

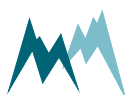

Reason	Solution
The Modbus master does not read the input register (function 04, protocol address 3xxx).	Verify that the Modbus master reads the input register.
The Modbus master reads the wrong registers. Depending on the Modbus master, register numbering may start at 0 or 1. For example, a measurement value is on input register 02. This corresponds to the protocol address 30002 or 30003.	Increment the register address by 1 if you don't know the numbering base of the Modbus master.
The returned hex-value is converted to the wrong data type.	Generally, measurement values are 4-byte floats. Verify that values are converted to float, not decimal or any other type.
Endianness of the Modbus polling unit is swapped. Generally, test values and measurement values are set to big endian. Older firmware versions may return measurement values as little endian.	If the device runs on an older firmware, convert the measurement values to float with little endian.
The signal wires between the Modbus master and the slaves are long and/or the ground potentials of the devices are different.	<ul style="list-style-type: none"> ■ Connect the grounds of the devices with an additional wire. ■ Reduce the cable length.

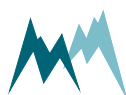

Appendix C CRC-16 array

CRC-16 array

```
1  crc16tab[] =
2  {
3  0x0000, 0x1021, 0x2042, 0x3063, 0x4084, 0x50A5, 0x60C6, 0x70E7,
4  0x8108, 0x9129, 0xA14A, 0xB16B, 0xC18C, 0xD1AD, 0xE1CE, 0xF1EF,
5  0x1231, 0x0210, 0x3273, 0x2252, 0x52B5, 0x4294, 0x72F7, 0x62D6,
6  0x9339, 0x8318, 0xB37B, 0xA35A, 0xD3BD, 0xC39C, 0xF3FF, 0xE3DE,
7  0x2462, 0x3443, 0x0420, 0x1401, 0x64E6, 0x74C7, 0x44A4, 0x5485,
8  0xA56A, 0xB54B, 0x8528, 0x9509, 0xE5EE, 0xF5CF, 0xC5AC, 0xD58D,
9  0x3653, 0x2672, 0x1611, 0x0630, 0x76D7, 0x66F6, 0x5695, 0x46B4,
10 0xB75B, 0xA77A, 0x9719, 0x8738, 0xF7DF, 0xE7FE, 0xD79D, 0xC7BC,
11 0x48C4, 0x58E5, 0x6886, 0x78A7, 0x0840, 0x1861, 0x2802, 0x3823,
12 0xC9CC, 0xD9ED, 0xE98E, 0xF9AF, 0x8948, 0x9969, 0xA90A, 0xB92B,
13 0x5AF5, 0x4AD4, 0x7AB7, 0x6A96, 0x1A71, 0x0A50, 0x3A33, 0x2A12,
14 0xDBFD, 0xCBDC, 0xFBBF, 0xEB9E, 0x9B79, 0x8B58, 0xBB3B, 0xAB1A,
15 0x6CA6, 0x7C87, 0x4CE4, 0x5CC5, 0x2C22, 0x3C03, 0x0C60, 0x1C41,
16 0xEDAE, 0xFD8F, 0xCDEC, 0xDDCD, 0xAD2A, 0xBD0B, 0x8D68, 0x9D49,
17 0x7E97, 0x6EB6, 0x5ED5, 0x4EF4, 0x3E13, 0x2E32, 0x1E51, 0x0E70,
18 0xFF9F, 0xEFBE, 0xDFDD, 0xCFFC, 0xBF1B, 0xAF3A, 0x9F59, 0x8F78,
19 0x9188, 0x81A9, 0xB1CA, 0xA1EB, 0xD10C, 0xC12D, 0xF14E, 0xE16F,
20 0x1080, 0x00A1, 0x30C2, 0x20E3, 0x5004, 0x4025, 0x7046, 0x6067,
21 0x83B9, 0x9398, 0xA3FB, 0xB3DA, 0xC33D, 0xD31C, 0xE37F, 0xF35E,
22 0x02B1, 0x1290, 0x22F3, 0x32D2, 0x4235, 0x5214, 0x6277, 0x7256,
23 0xB5EA, 0xA5CB, 0x95A8, 0x8589, 0xF56E, 0xE54F, 0xD52C, 0xC50D,
24 0x34E2, 0x24C3, 0x14A0, 0x0481, 0x7466, 0x6447, 0x5424, 0x4405,
25 0xA7DB, 0xB7FA, 0x8799, 0x97B8, 0xE75F, 0xF77E, 0xC71D, 0xD73C,
26 0x26D3, 0x36F2, 0x0691, 0x16B0, 0x6657, 0x7676, 0x4615, 0x5634,
27 0xD94C, 0xC96D, 0xF90E, 0xE92F, 0x99C8, 0x89E9, 0xB98A, 0xA9AB,
28 0x5844, 0x4865, 0x7806, 0x6827, 0x18C0, 0x08E1, 0x3882, 0x28A3,
29 0xCB7D, 0xDB5C, 0xEB3F, 0xFB1E, 0x8BF9, 0x9BD8, 0xABBB, 0xBB9A,
30 0x4A75, 0x5A54, 0x6A37, 0x7A16, 0x0AF1, 0x1AD0, 0x2AB3, 0x3A92,
31 0xFD2E, 0xED0F, 0xDD6C, 0xCD4D, 0xBDAA, 0xAD8B, 0x9DE8, 0x8DC9,
32 0x7C26, 0x6C07, 0x5C64, 0x4C45, 0x3CA2, 0x2C83, 0x1CE0, 0x0CC1,
33 0xEF1F, 0xFF3E, 0xCF5D, 0xDF7C, 0xAF9B, 0xBFBA, 0x8FD9, 0x9FF8,
34 0x6E17, 0x7E36, 0x4E55, 0x5E74, 0x2E93, 0x3EB2, 0x0ED1, 0x1EF0
35 }
```

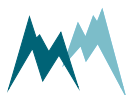

Glossary

I

IP-Call

A technology that provides communication services over the Internet.

M

Modbus

A serial communications protocol for connecting industrial electronic devices.

R

RS-485

A standard defining the signal transmission in serial communication systems.

S

SBP

Sommer Bus Protocol

SDI-12

Asynchronous serial communications protocol for intelligent sensors (Serial Digital Interface at 1200 baud)

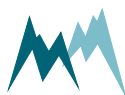

Index

M

Modbus 21-22, 54, 81-82, 88, 90-91, 104,
106, 126, 129

R

RS-485 14, 21-22, 25, 28, 37, 61-63, 72, 82-
83, 91, 104-105, 118, 126, 128-129

S

SDI-12 21-22, 26, 63, 76-80, 84, 102, 118,
129

