

DP-20

Density meter

Manual

Setup version 1.10 (Firmware 1.07)

19.01.2026



Sommer Messtechnik

All rights reserved.

The Copyrights for this manual are exclusively owned by

Sommer Messtechnik
6842 Koblach
Austria

This manual or parts of it may only be copied or passed on to third parties with written permission of Sommer Messtechnik. This applies to printed as well as digital issues of this manual.



Sommer Messtechnik
Strassenhäuser 27
6842 Koblach
Austria
www.sommer.at
E office@sommer.at
T +43 5523 55989

Validity

This manual applies to the Density meter with the setup version 1.10, including all its subversions.

Created: 01.01.2020

Last update: 19.01.2026

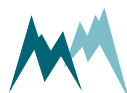

Safety information

Please read this manual carefully before installing or operating this equipment. Non-compliance with the instructions given in this manual can result in failure or damage of the equipment or may put people at risk by injuries through electrical or mechanic impact.

- Make sure that the personnel responsible for installation, configuration and maintenance is familiar with the applicable regulations and standards!
- Maintenance and repair must be performed by trained personnel or an engineer of Sommer Messtechnik. Only replacement parts supplied by Sommer Messtechnik should be used for repairs.
- Make sure that NO power is connected to the equipment during installation and wiring!
- Only use a power supply that complies with the power rating specified for this equipment!

- Keep equipment dry during wiring and maintenance!
- The in- and output tubing of the DP-20 must not be damaged! A dent in the tubing may require a recalibration of the device.
- If the DP-20 drops, the oscillating U-tube is likely to get misaligned. In such a case the DP-20 needs to be repaired and recalibrated by Sommer Messtechnik.
- Do not open the housing! This would allow moisture to enter the device, which may lead to condensation on the oscillating U-tube.
- Do not remove the membrane of the pressure balance fitting (located between the input- and output pipes)! This would allow moisture to enter the device, which may lead to condensation on the oscillating U-tube.
- If applicable, it is recommended to use accessories of Sommer Messtechnik with this equipment.



ATTENTION Warranty expires, if the warranty label on the DP-20 housing is broken!

Disposal



After this device has reached the end of its lifetime, it must not be disposed of with household waste! Instead, dispose of the device by returning it to a designated collection point for the recycling of waste electrical and electronic equipment.

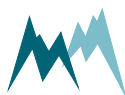

Feedback

Should you come across any error in this manual, or if you miss information to handle and operate the DP-20 we are pleased to receive your feedback to office@sommer.at.

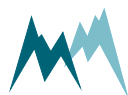

Content

- 1 What is the DP-20? 12
- 2 Unpacking 13
- 3 How the DP-20 works 14
- 4 Components 15
 - 4.1 MAIN connector 15
 - 4.2 PARAM connector 15
 - 4.3 Control connector 16
 - 4.4 LEDs 17
 - 4.5 LC-Display MD-10 17
- 5 Specifications 19
- 6 Dimensions 21
- 7 Installation 23
 - 7.1 Things to consider for installation 23
 - 7.1.1 Location 23
 - 7.1.2 Process integration 23
 - 7.1.3 Maximum cable length 24
 - 7.2 Required tools and equipment 24
 - 7.3 Mounting 25
 - 7.4 Wiring 25
 - 7.4.1 RS-485 wiring 25
 - 7.4.2 SDI-12 wiring 25
 - 7.4.3 How to wire analog outputs 26
 - 7.4.4 Wiring of the LC-Display MD-10 26
- 8 Operation 28
 - 8.1 Connect device to PC 28
 - 8.2 How to use the LC-Display MD-10 29
 - 8.2.1 Home screen 29
 - 8.2.2 LC-Display MD-10 map 29
 - 8.2.3 How to change a setting 30
 - 8.3 How to select a medium 31
 - 8.3.1 With the LC-Display MD-10 31
 - 8.3.2 With the Commander 31
 - 8.3.3 By Modbus 32
 - 8.4 How to select a medium with an external switch 32
 - 8.5 How to change the set point 33
 - 8.5.1 With the LC-Display MD-10 33
 - 8.5.2 With the Commander 33

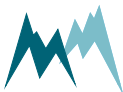

8.5.3	By Modbus	33
8.6	How to add a custom medium	33
8.6.1	With the LC-Display MD-10	33
8.6.2	With the Commander	34
8.7	How to activate mixing control	34
9	Maintenance	36
10	Support software Commander	37
10.1	Software features	37
10.2	System requirements	37
10.3	Installation of Commander	37
10.4	Change authorization	42
10.5	Working with connections	43
10.5.1	Establish a connection with the Communication assistant	43
10.5.2	Establish a connection manually	43
10.5.3	Create a new connection	43
10.6	Working with stations	44
10.6.1	Create a station with the Communication assistant	44
10.6.2	Create a station manually	49
10.7	Working with measurements	50
10.7.1	Poll continuous measurements	50
10.7.2	Record measurements	50
10.8	Working with data	51
10.8.1	View live data	51
10.9	Working with setups	52
10.9.1	Download setup	52
10.9.2	Open a setup file	52
10.9.3	Edit setup	52
10.9.4	Upload new setup file	53
10.10	Update firmware	53
11	Configuration of the DP-20	55
11.1	Software tools	55
11.2	Configuration with Commander support software	55
11.3	Configuration with a terminal program	58
12	Communication	60
12.1	Communication protocols	60
12.2	Data output	60
12.2.1	Main values	60
12.2.2	Measurement status	60
12.2.3	Exception values	62

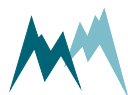

12.3	RS-485	63
12.3.1	What is RS-485?	63
12.3.2	What can I do with it?	63
12.3.3	Configuration	63
12.3.4	Data output options	64
12.3.5	Sommer Bus Protocol (SBP)	65
12.3.6	Standard protocol	67
12.3.7	RS-485 commands	69
12.3.8	Sommer Messtechnik CRC-16	71
12.4	SDI-12	72
12.4.1	What is SDI-12?	72
12.4.2	What can I do with it?	73
12.4.3	Configuration	73
12.4.4	Data structure	73
12.4.5	SDI-12 commands	74
12.5	Modbus	78
12.5.1	What is Modbus?	78
12.5.2	What can I do with it?	78
12.5.3	Wiring	79
12.5.4	Modbus configuration	79
12.5.5	Modbus commands and registers	85
12.5.6	Reactivate Sommer Bus Protocol	89
12.5.7	PLC integration	94
13	Analog output	95
13.1	What can I do with it?	95
13.2	Scaling	95
13.3	IOOUT 1	95
13.3.1	Density output	95
13.3.2	Concentration output	96
13.4	IOOUT 2	97
13.5	Simulate current output	97
14	Parameter definitions	98
A	Medium	98
B	Medium settings	98
B-A	NaCl settings	98
B-A-A	Set-point	99
B-A-B	Minimum set-point	99
B-A-C	Maximum set-point	99
B-A-D	IOOUT1 concentration span	99

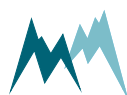

	B-A-E	IOU1 concentration min. value	100
	B-A-F	Set-point range +/-	100
B-B		CaCl ₂ settings	100
	B-B-A	Set-point	100
	B-B-B	Minimum set-point	101
	B-B-C	Maximum set-point	101
	B-B-D	IOU1 concentration span	101
	B-B-E	IOU1 concentration min. value	102
	B-B-F	Set-point range +/-	102
B-C		MgCl ₂ settings	102
	B-C-A	Set-point	102
	B-C-B	Minimum set-point	103
	B-C-C	Maximum set-point	103
	B-C-D	IOU1 concentration span	103
	B-C-E	IOU1 concentration min. value	104
	B-C-F	Set-point range +/-	104
B-D		Custom medium settings	104
	B-D-A	Set-point	104
	B-D-B	Minimum set-point	105
	B-D-C	Maximum set-point	105
	B-D-D	IOU1 concentration span	105
	B-D-E	IOU1 concentration min. value	106
	B-D-F	Set-point range +/-	106
	B-D-G	User tables	106
		B-D-G-A Num. of temperatures	106
		B-D-G-B Temperature table	107
		B-D-G-C Num. of concentrations	107
		B-D-G-D Concentration table	107
		B-D-G-E Density table	107
	B-D-H	Medium name	107
C		Technics	108
	C-A	Language/Sprache	108
	C-B	Decimal character	108
	C-C	Units and decimals	109
		C-C-A Temperature, unit	109
	C-D	Density measurement	109
		C-D-A Adjustment active	109
		C-D-B Concentration adjustment	109
		C-D-C Density adjustment	110



C-E	Measurement range monitoring	110
	C-E-A Delay 'Out of range'	110
C-F	Mixer controller	110
	C-F-A Proportional factor	110
	C-F-B Differential factor	110
	C-F-C Control interval	111
	C-F-D Minimum pulse length	111
	C-F-E Input delay	111
C-G	Temperature	111
	C-G-A Medium temperature offset	112
	C-G-B Internal temperature offset	112
	C-G-C Test temperatures	112
	C-G-D Adjust temperatures	112
C-H	IOUT settings	112
	C-H-A IOUT1, output option	113
	C-H-B IOUT1, output parameter	113
	C-H-C IOUT1, density span	113
	C-H-D IOUT1, density min. value	113
	C-H-E IOUT2, 4-20 mA span	114
	C-H-F IOUT2, 4 mA value	114
	C-H-G Simulate current output	114
C-I	Advanced settings	114
	C-I-A Sommer ID	114
C-J	SDI-12 service	115
	C-J-A SDI-12 address	115
	C-J-B SDI12 Information	115
	C-J-C SDI12 'M'-response	115
C-K	Measurement output interval	116
C-L	RS-485-1 Protocol	116
	C-L-A Device number	117
	C-L-B System key	117
	C-L-C Output protocol (OP)	117
	C-L-D Measurement output	118
	C-L-E Information	118
	C-L-F Wake-up sequence	118
	C-L-G Prefix holdback	119
C-M	RS-485-1 Port	119
	C-M-A Baudrate	119
	C-M-B Parity, stop bits	120

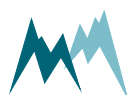

	C-M-C	Minimum response time	120
	C-M-D	Transmitter warm-up time	121
	C-M-E	Flow control	121
	C-M-F	Sending window	121
	C-M-G	Receiving window	121
C-N	RS-485-2 Port		122
	C-N-A	Baudrate	122
	C-N-B	Parity, stop bits	122
	C-N-C	Minimum response time	123
	C-N-D	Transmitter warm-up time	123
	C-N-E	Flow control	123
	C-N-F	Sending window	124
	C-N-G	Receiving window	124
	C-N-H	Parallel measurement output	124
	C-N-I	MODBUS, set default	125
	C-N-J	MODBUS, device address	125
D	Special functions		125
	D-A	Device status	125
	D-B	Set factory default	126
	D-C	Temp. load factory default	126
	D-D	Relaunch program	126
	D-E	Replace program	126
E	Measurement table		126
Appendix O	Troubleshooting		127
	O.1	Devices	127
		O.1.1 The DP-20 is not responding or returns unreadable characters	127
		O.1.2 The DP-20 reboots repeatedly	129
	O.2	Measurement data	129
		O.2.1 Measurement data are not updated	129
		O.2.2 DP-20 reports a medium error	129
		O.2.3 DP-20 reports a temperature error	129
	O.3	Firmware & software	130
		O.3.1 Commander loads wrong setup	130
		O.3.2 Firmware update via RS-485 is aborted	130
	O.4	RS-485	130
		O.4.1 Configuration via terminal shows unexpected behavior	130
	O.5	SDI-12	131
		O.5.1 The DP-20 is not detected by a SDI-12 master device	131
		O.5.2 Data logger receives no SDI-12 data	131

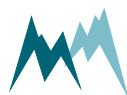

O.6	Analog output	131
O.6.1	The 4-20 mA output is wrong	131
Appendix P	CRC-16 array	133

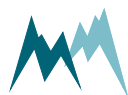

1 What is the DP-20?

The DP-20 determines the concentration of salt solutions by measuring their densities with a highly precise oscillating U-tube. With three predefined media – NaCl, CaCl₂ and MgCl₂—the DP-20 is ready for continuous monitoring directly in the liquid stream or in a bypass.

With highly corrosion resistant stainless steel tubing and PE-HD housing the DP-20 can be used in highly aggressive environments. A switchboard mountable LC-Display MD-10 (available as an optional accessory) provides easy visual control of salt concentration and medium density.

In the M-version the DP-20 enables direct mixing of the salt solution with an integrated PD-controller and switch outputs.

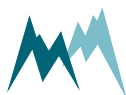

2 Unpacking

When unpacking your DP-20 sensor box please make sure that the following items are present:

Qty	Art	Name
1	21399	DP-20 density meter for NaCl, CaCl ₂ , MgCl ₂
1	21737	MAIN cable for DP-20, 5 m, 8 pins
1	21734	CONTROL cable for DP-20, 5 m, 8 pins (DP-20MR only)
1	18349	USB-stick incl. software and manual

In case of missing or damaged items please contact your Sommer Messtechnik sales partner.

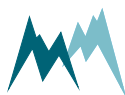

3 How the DP-20 works

The DP-20 measures the oscillation frequency of an electronically excited U-shaped tube filled with the liquid medium. From the oscillation period at the characteristic frequency of the U-tube and two instrument constants the density of the medium is calculated with very high precision. A temperature sensor outside the U-tube is used to compensate for temperature effects on the oscillation. Finally, the salt concentration is deduced from the exact relationship between density and temperature dependent concentration. The monitored variables – density, salt concentration and medium temperature – are displayed on a switchboard mountable LC-Display MD-10.

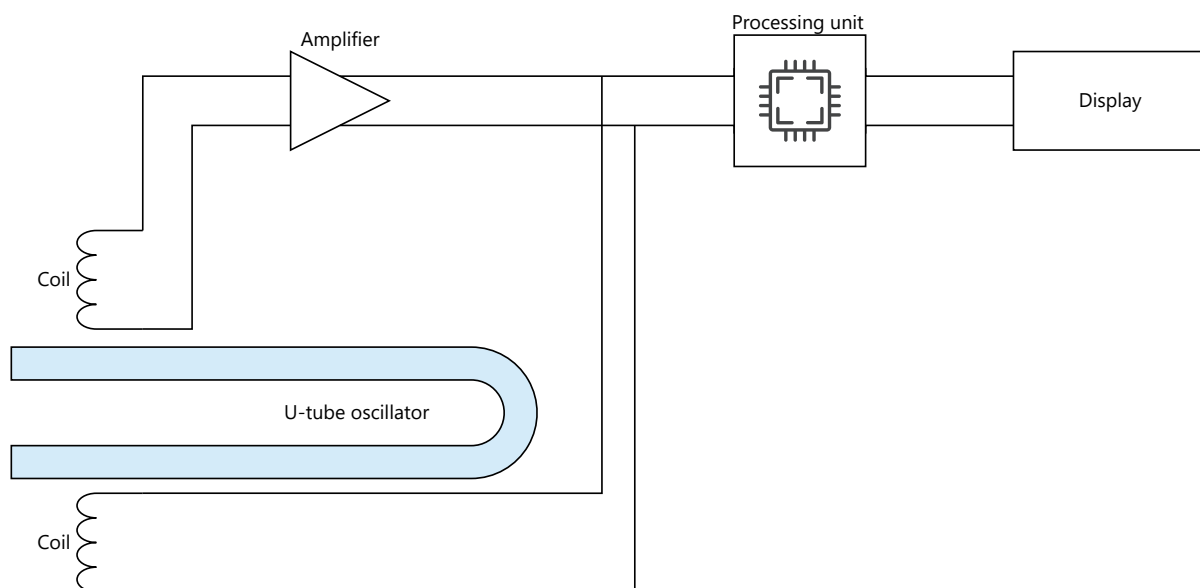

The DP-20 is pre-configured for solutions of NaCl, CaCl₂ and MgCl₂, which can either be selected over the Commander support software or remotely by three digital inputs. An additional custom solution can be configured by means of a density-concentration-temperature table.

With the mixing controller inside the M-version of the DP-20 salt solutions can be produced directly. The PD-controller automatically operates two switch outputs which drive the relays of the mixing valve and pump.

4 Components

4.1 MAIN connector

This 8-pin plug provides RS-485, SDI-12 and analog outputs for connection to a data acquisition system.

	Pin	Colour*	Function	Description
Power supply	1	white	GND	Ground
	2	brown	Vsupply	9...28 VDC
Ground	3	green	GND	Sensor ground
RS-485 interface	4	yellow	RS485 A	1 x RS-485 (1200...115200 Baud)
	5	grey	RS485 B	
SDI-12 interface	6	pink	SDI-12	1 x SDI-12 (1200 Baud)
Analog outputs	7	blue	IOU2	Temperature (4...20 mA)
	8	red	IOU1	Density or concentration (4...20 mA, 0 ... 20 mA, 0 ... 10 VDC)

*Wire color of the provided "Sommer" cable



NOTE The analog outputs are referenced to GND on pin 3.

4.2 PARAM connector

This 5-pin socket connects the LC-Display MD-10 and is used for configuration with the Commander support software.



	Pin	Colour*	Function	Description
Power output	1	brown	Vsupply	12-VDC supply for external LC-Display MD-10
	2	white	GND	Ground
RS-485 interface	3	yellow	RS485 A	1 x RS-485 (1200...115200 Baud)
	4	grey	RS485 B	
SDI-12 interface	5	-	-	Inactive

*Wire color of the provided "Sommer" cable

4.3 Control connector

This 8-pin socket provides digital inputs for remote medium selection and switch outputs for status monitoring and mixing control.

	Pin	Colour*	Function	Description
Control input	1	white	IN1	Activates mixing control by DP-20
	2	brown	IN2	Selects medium NaCl from external switch
	3	green	IN3	Selects medium CaCl ₂ from external switch
	4	yellow	IN4	Selects medium MgCl ₂ from external switch
Switch output	5	gray	OUT1	Not used
	6	pink	OUT2	Status: Concentration outside limits
	7	blue	OUT3	Status: Concentration is below limit/ Controller output to drive relay**
	8	red	OUT4	Status: Concentration is above limit/ Controller output to drive relay**

*Wire color of the provided "Sommer" cable

**See [How to activate mixing control](#)



NOTE The digital in- and outputs are referenced to GND on pin 3 of the MAIN connector.

4.4 LEDs

The status LEDs at the back of the instrument indicate the following status:

LED	Function
ON	Instrument power is on
Actual value OK	Concentration is within range
Out of range	Concentration is out of range
Actual value too high	Concentration is above limit
Actual value too low	Concentration is below limit

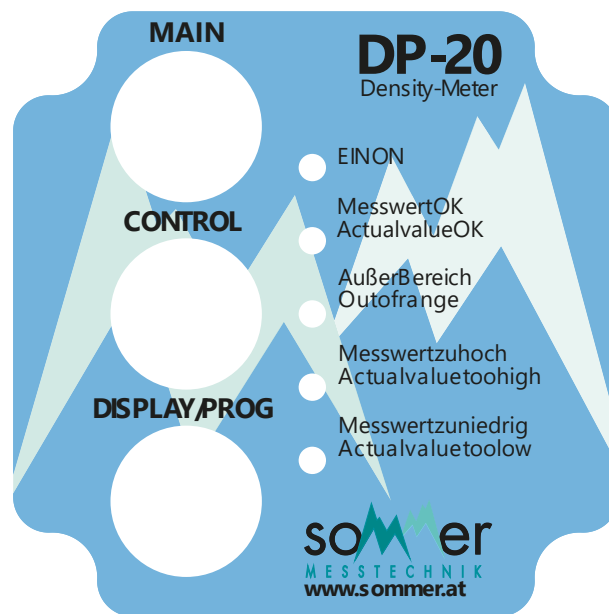

4.5 LC-Display MD-10

The panel mountable LC-Display MD-10 can be used to view the current measurement values and the integrated keyboard allows configuration of basic settings.

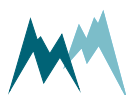

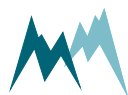
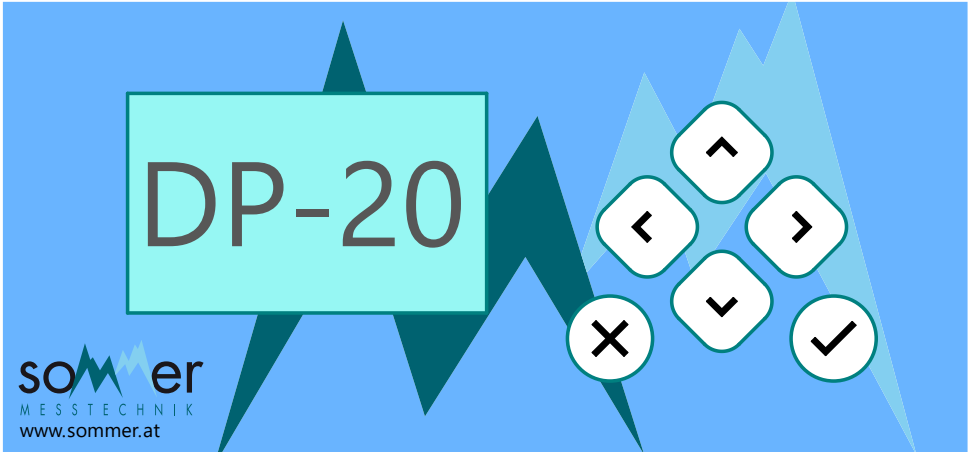

5 Specifications

Sensor	
Principle	Oscillating U-tube
Media	NaCl, CaCl ₂ , MgCl ₂
Measurement range	0.5000 ... 2.0000 g/cm ³
Resolution	0.002 g/cm ³
Medium temperature	-20°C ... +50°C
Measurement lag	<1 second
Medium selection	Via digital input or setup (NaCl, CaCl ₂ , MgCl ₂)
Configuration	PC or optional LC-Display MD-10

Power	
Power supply	10 ... 30 VDC; reverse voltage protection, overvoltage protection
Power consumption at 12 VDC	120 mA

Interfaces	
Inputs	4x digital input for medium selection and external mixing control (high 6 ... 24 VDC, low 0 ... 5 VDC); requires surge protection
Outputs	4x open-collector (pull down) output, 0.25 A @ 24 VDC 1x analog 4 ... 20 mA (medium temperature) 1x analog 4 ... 20 mA, 0 ... 20 mA or 0 ... 10 VDC (density or concentration) 2x RS-485 Sommer bus protocol, Modbus, SDI-12

Physical and environmental	
Material oscillating U-tube	Acid-proof stainless steel 1.4539, highly corrosion-resistant (application in chemical, food and pharmaceutical industries, marine environments)
U-tube volume	60 cm ³
Flow rate	0.3 ... 6.0 l/min
Max. pressure	20 bar



Physical and environmental

Housing material	ABS (housing profile), PE-HD (housing covers)
Process connection	Blank tube outer- \varnothing 10 mm, inner- \varnothing 8 mm,(other fittings on request)
Operating temperature	-30 ... +60°C
Size L x W x H	429 x 148 x 133 mm
Weight	2580 g



6 Dimensions

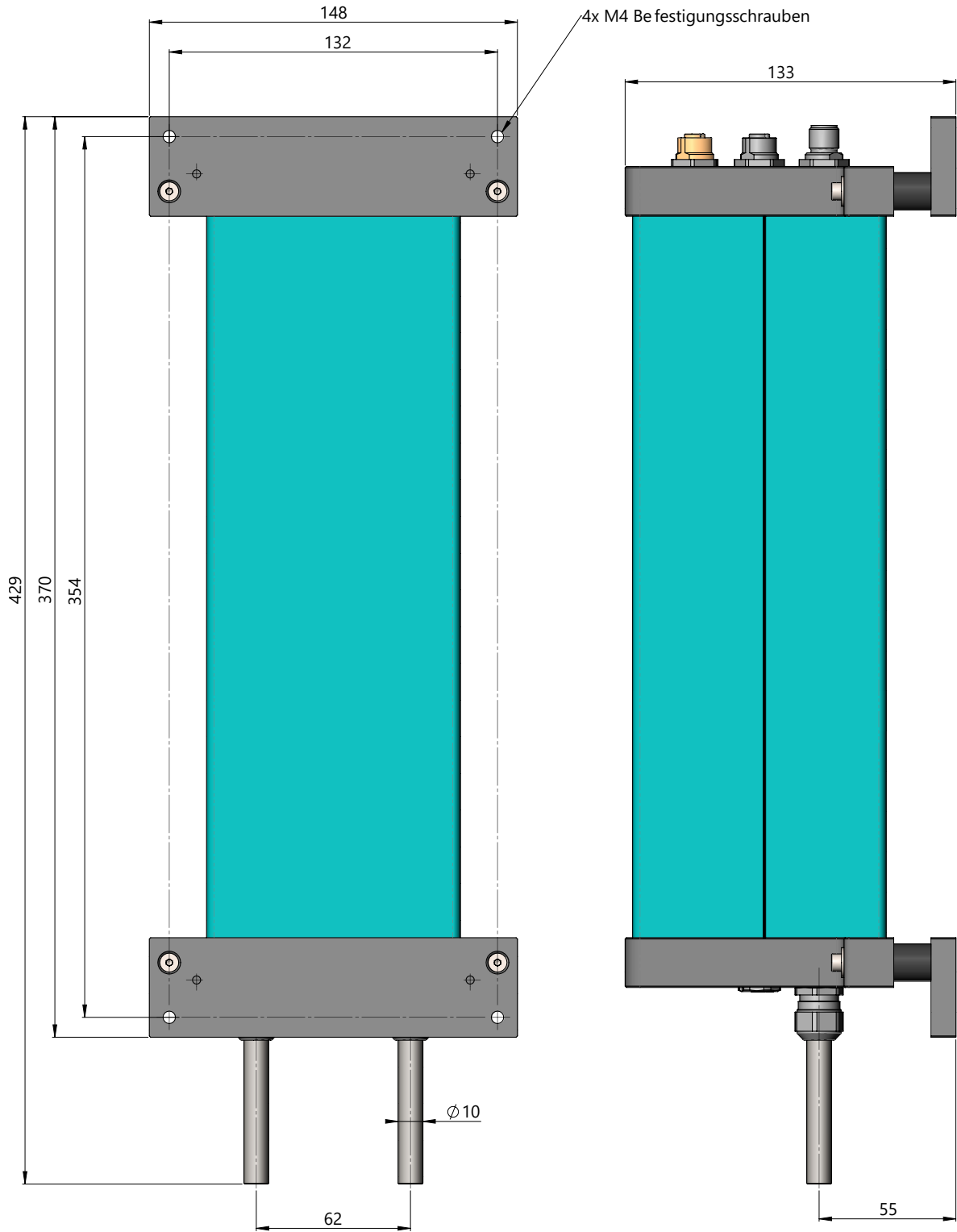
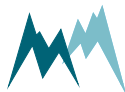

Figure 1 Dimensions DP-20 dimensions



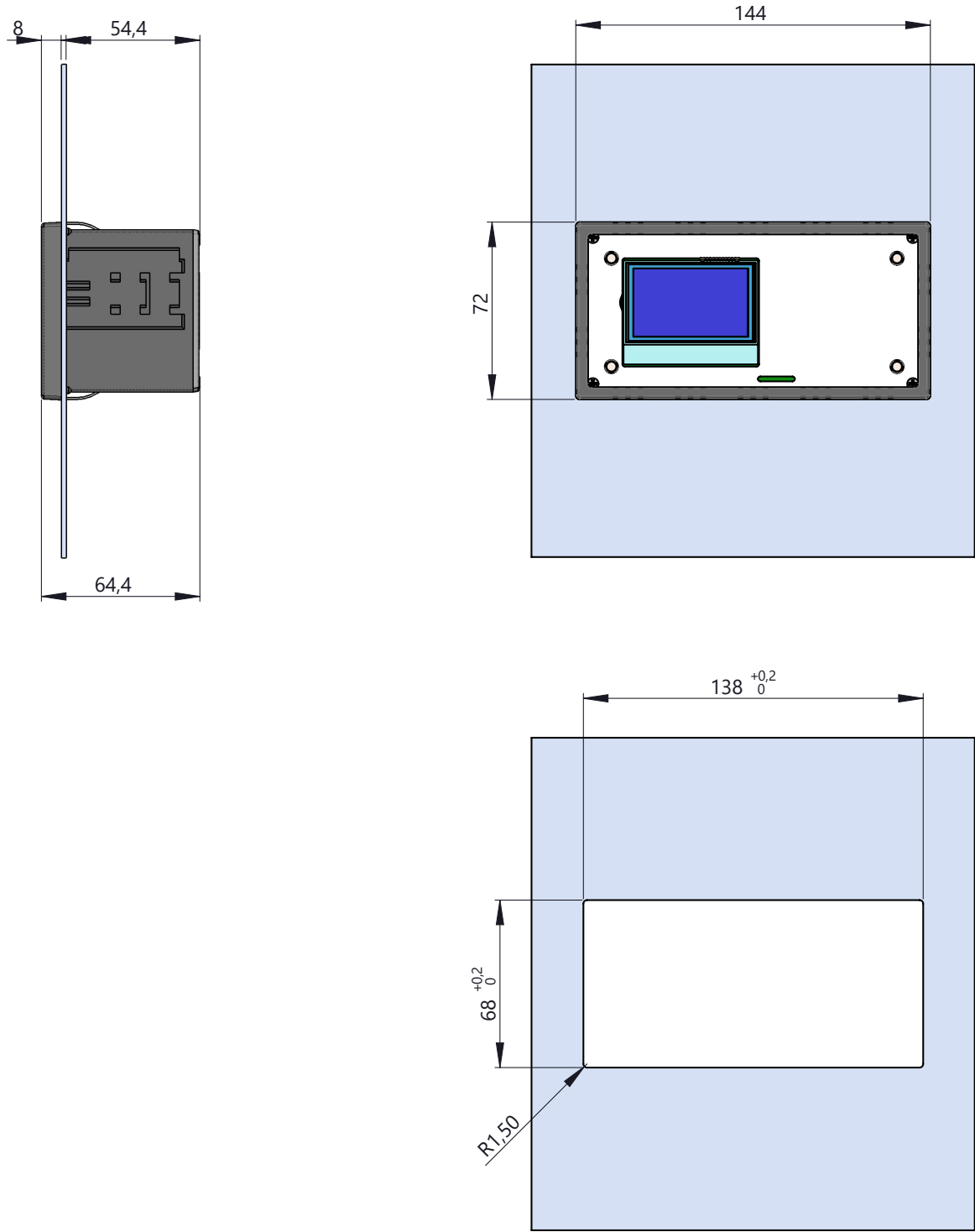
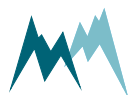

Figure 2 Dimensions LC-Display MD-10



7 Installation

7.1 Things to consider for installation

7.1.1 Location

The DP-20 should not be installed close to any machinery that may cause excessive vibrations or electromagnetic interferences!

7.1.2 Process integration

Depending on the liquid flow rate the DP-20 can be mounted in-line or within a bypass.

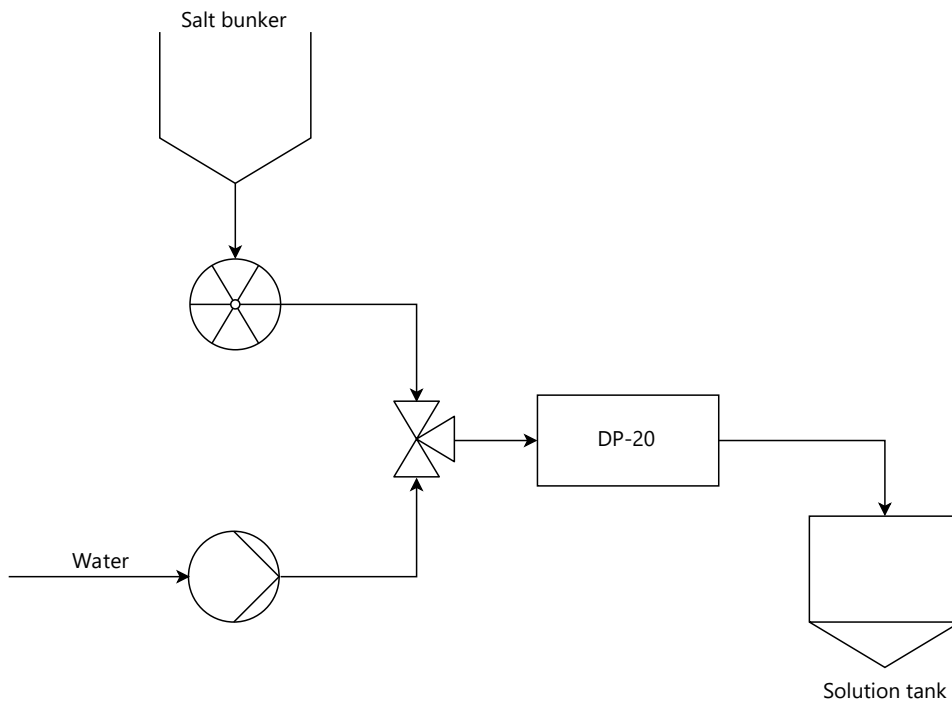
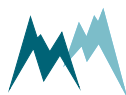

Figure 3 In-line mounting of the DP-20



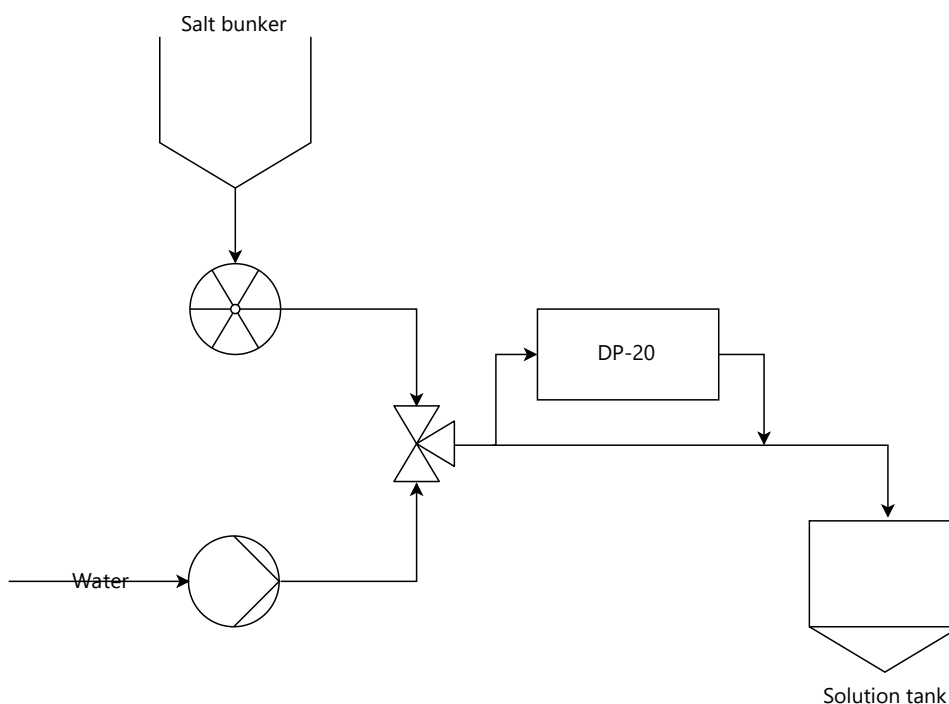

Figure 4 Bypass mounting of the DP-20

7.1.3 Maximum cable length

Please consider the maximum cable lengths for the applied transmission protocol:

Cross section	Max. cable length
12 × 0,25 mm ²	~60 m (depending on wire cross section and number of sensors)
12 × 0,75 mm ²	~300 m

Table 1 Maximum cable lengths



NOTE Cable lengths longer than 60 m require a heavier gauge wire if the power supply drops below 11 V.

7.2 Required tools and equipment

Prepare the following tools and equipment to install the DP-20:

Qty	Tool/Equipment
1	DC power supply 9...28 VDC
-	Hoses or tubing for connection to Ø10-mm medium in- and outlet
2	Hose clamps or tube fittings
4	M4 bolts for mounting of DP-20

7.3 Mounting

The DP-20 instrument can be mounted on the wall in any direction with four M4 bolts of suitable length. See [Dimensions](#) for the position of drill holes.

The LC-Display MD-10 can be mounted to a control panel with spring clamps. For cut of the front panel see [Dimensions](#).

7.4 Wiring

7.4.1 RS-485 wiring

Connect the DP-20 to a PLC or RS-485 network according to the figure below.

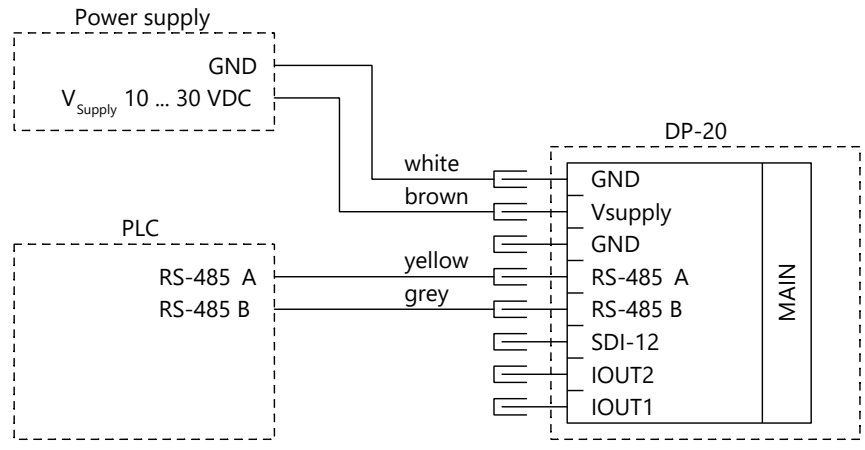

7.4.2 SDI-12 wiring

Connect the DP-20 to a PLC by SDI-12 according to the figure below.

SDI-12 uses a shared bus with a ground wire, a data wire (indicated as SDI-12) and an optional +12 V wire.

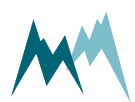



NOTE The connection with the 12 V power supply is optional and depends on the connected SDI-12 master device (PLC).

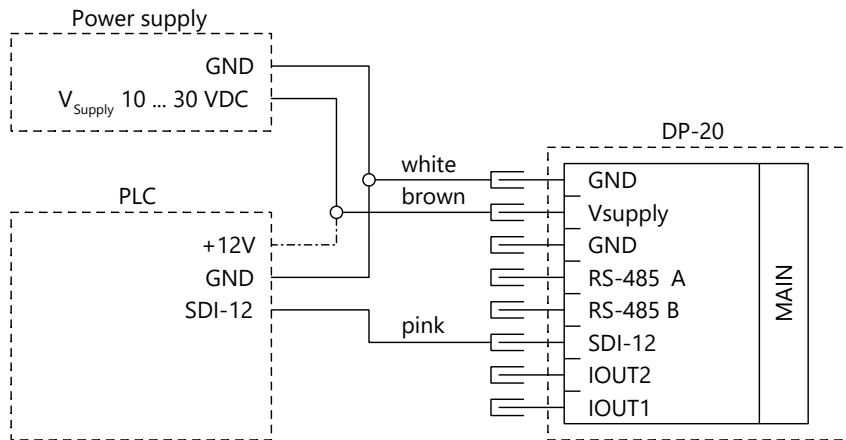

7.4.3 How to wire analog outputs

Connect the analog outputs of the DP-20 to a data acquisition device according to the figure below.

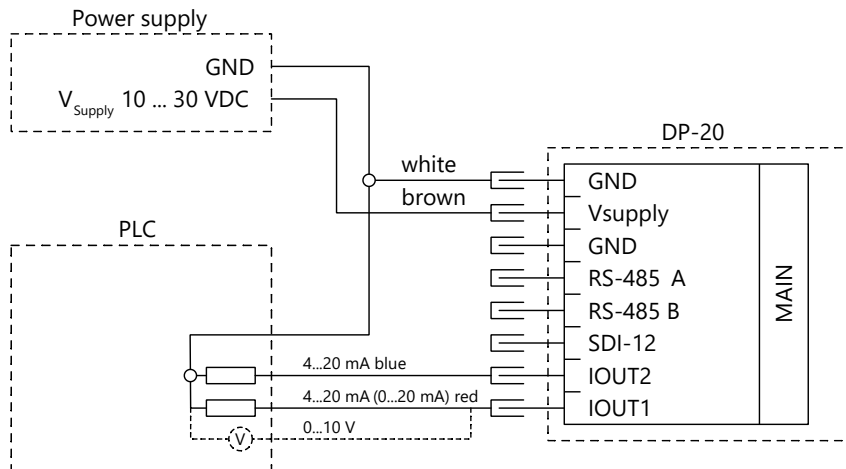

NOTE If a data acquisition system is connected to the IOU2 outputs, the resistance of the input(s) must not exceed 470 Ω .

7.4.4 Wiring of the LC-Display MD-10

The panel-mount LC-Display MD-10 is wired to the DP-20 as shown below.

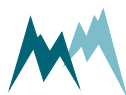
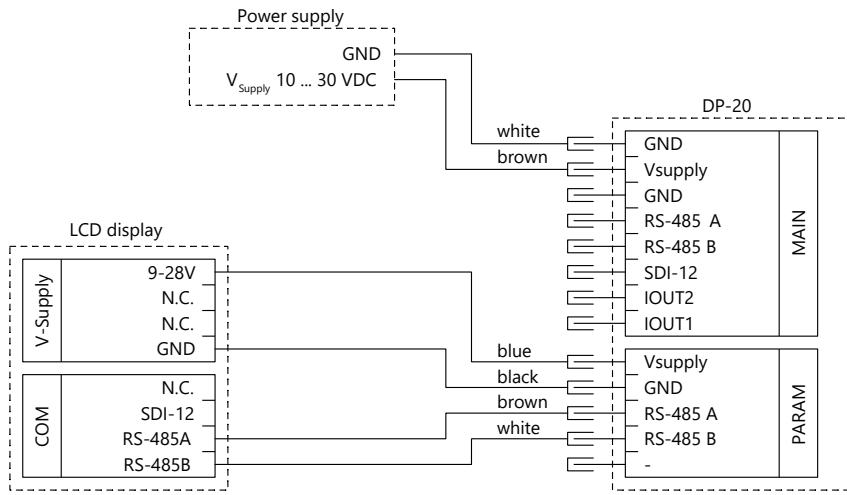

8 Operation

8.1 Connect device to PC

1. Install the Commander support software (see [Installation of Commander](#)).
2. Connect the yellow and gray wires of the sensor cable to the RS-485 to USB converter cable and plug it into your PC as illustrated in the figure below.
3. Connect a 9...28 VDC power supply to the DP-20 as shown in the figure below.
4. Click on **Communication assistant** on the right-hand side of the Commander window and follow the instructions.
 - a. As **Type of connection** select *Serial connection*
 - b. As **Device type** select *Sensor (9600 Bd)*
 - c. Select **New connection** and select the COM port

During this procedure the communication assistant will search for connected devices. Upon successful completion, the new connection is added to the connections list (tab **Connections (F8)**).

5. In the **Communication** section at the right-hand side of the Commander window select Mode **Connection** and the previously created connection from the drop-down list.
6. Click **Connect** to establish a connection with the DP-20. If the connection was successful a green icon is displayed at the top-right corner of the Commander window.
7. Select the tab **Parameters (F2)** and click **Download parameters from device** on the left side of the Commander window. The complete parameter list is transferred from the sensor to your PC and displayed in the **Parameter** window.

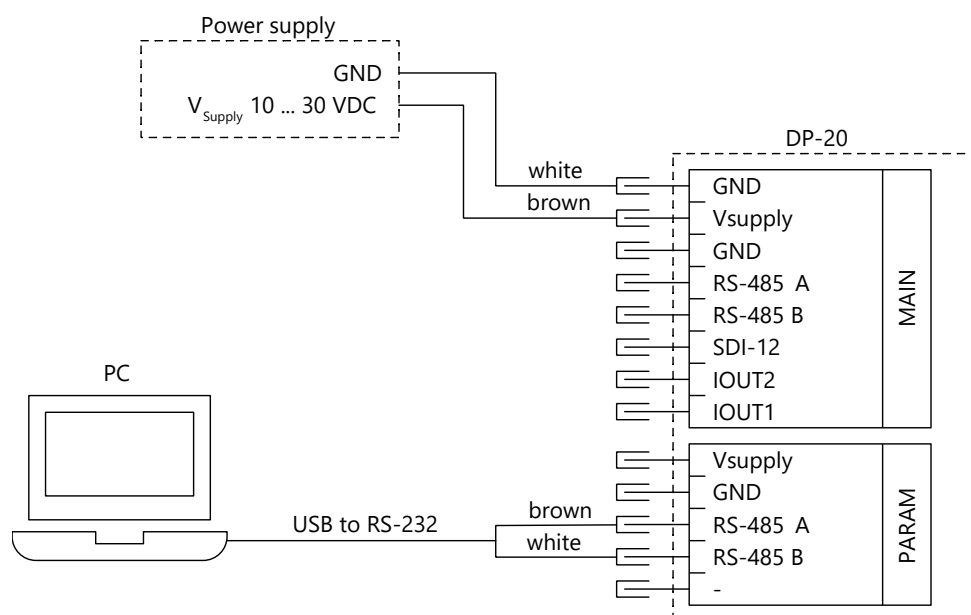



To activate the communication between your device and the Commander software follow the steps described in [Working with connections](#).

8.2 How to use the LC-Display MD-10

8.2.1 Home screen

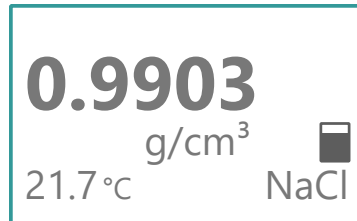
The default home screen of the LC-Display MD-10 has the following look:



The displayed temperature is the medium temperature and  indicates the quality of the measurements, where a filled box refers to good and an empty box to erroneous measurements (e.g. air bubbles in the U-tube).

8.2.2 LC-Display MD-10 map

The LC-Display MD-10 provides the following screen menus:

Screen	Configuration options
<div style="border: 1px solid black; padding: 5px;"> <h2 style="margin: 0;">Display</h2> <hr style="border: 0; border-top: 1px solid black; margin: 2px 0;"/> <p style="margin: 0;">Density + Temp.</p> </div>	<p>Select the variables to display. The options are:</p> <ul style="list-style-type: none"> ■ Density + Temperature ■ Concentration + Temperature ■ Set + Actual (set-point and measured concentrations) ■ Concentration
<div style="border: 1px solid black; padding: 5px;"> <h2 style="margin: 0;">Medium</h2> <hr style="border: 0; border-top: 1px solid black; margin: 2px 0;"/> <p style="margin: 0;">NaCl</p> </div>	<p>Select the monitored medium. The options are:</p> <ul style="list-style-type: none"> ■ NaCl ■ CaCl₂ ■ MgCl₂ ■ custom ■ external
<div style="border: 1px solid black; padding: 5px;"> <h2 style="margin: 0;">Set point</h2> <hr style="border: 0; border-top: 1px solid black; margin: 2px 0;"/> <p style="margin: 0;">Settings</p> </div>	<p>Define the set-point:</p> <ul style="list-style-type: none"> ■ Set-point of solute concentration ■ Range +/- (accepted variance of the set-point) ■ Alarm delay (Time before an alarm is triggered when set-point has not been reached) <p> NOTE Depending on the values listed above (set-point, range, alarm delay), which can be set separately for each medium, the LC-Display MD-10 lights up green if the deviation of the concentration from the set-point is smaller than the set range, otherwise red.</p>
<div style="border: 1px solid black; padding: 5px;"> <h2 style="margin: 0;">Offset</h2> <hr style="border: 0; border-top: 1px solid black; margin: 2px 0;"/> <p style="margin: 0;">Settings</p> </div>	<p>Adjust density and concentration measurements to a known standard:</p> <ul style="list-style-type: none"> ■ Adjust density ■ Adjust conc. ■ Adjustment (if on, the measurement values are corrected according to the adjustment values)
<div style="border: 1px solid black; padding: 5px;"> <h2 style="margin: 0;">System</h2> <hr style="border: 0; border-top: 1px solid black; margin: 2px 0;"/> <p style="margin: 0;">Settings</p> </div>	<p>Define device and software settings:</p> <ul style="list-style-type: none"> ■ Language (currently only EN and DE) ■ Info (displays hardware designation and software versions)

8.2.3 How to change a setting

The settings listed in the [LC-Display MD-10 map](#) can be changed with the following steps:

1. Switch into the settings mode by pressing \leftarrow and \rightarrow simultaneously.
2. Navigate to the desired menu with \uparrow and \downarrow .
3. Press \checkmark to enter the submenu or the setting. If you have entered a setting, a ? is displayed next to the name of the setting.
4. Select the required option or change the value:
 1. Select an option by pressing \leftarrow and \rightarrow .
 2. To change a value select the required digit with \leftarrow and \rightarrow and increase/decrease the number with \uparrow and \downarrow .
5. Confirm the new selection/value with \checkmark .
6. Navigate back with \otimes .

8.3 How to select a medium

8.3.1 With the LC-Display MD-10

Enter into the settings mode, navigate to **Medium** and select one of the options listed below.

8.3.2 With the Commander

In the parameter menu **Medium** select one of the following media:

ID	Option	Description
1	no medium	No medium is selected and the DP-20 only measures density.
2	NaCl	Solute NaCl is active and its concentration [% m/v] is returned.
3	CaCl ₂	Solute CaCl ₂ is active and its concentration [% m/v] is returned.
4	MgCl ₂	Solute MgCl ₂ is active and its concentration [% m/v] is returned.
5	custom medium	A custom solute is active and its concentration [% m/v] is returned.
6	external input	One of the media NaCl, CaCl ₂ and MgCl ₂ is selected by an external switch and the DP-20 digital inputs IN2, IN3, IN4.

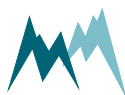

8.3.3 By Modbus

Write the medium ID of the required medium to holding register address **101**. See table above.

8.4 How to select a medium with an external switch

1. Connect a 3-way switch to the inputs IN2, IN3 and IN4 of the CONTROL connector as illustrated below.
2. On the LC-Display MD-10 enter into the setup mode and in the menu **Medium** select *external input*. Alternatively, open the parameter menu in the Commander and change the setting **Medium** to *external input*. The medium can also be set to *external input* by writing the value **6** to the Modbus holding register address **101**.

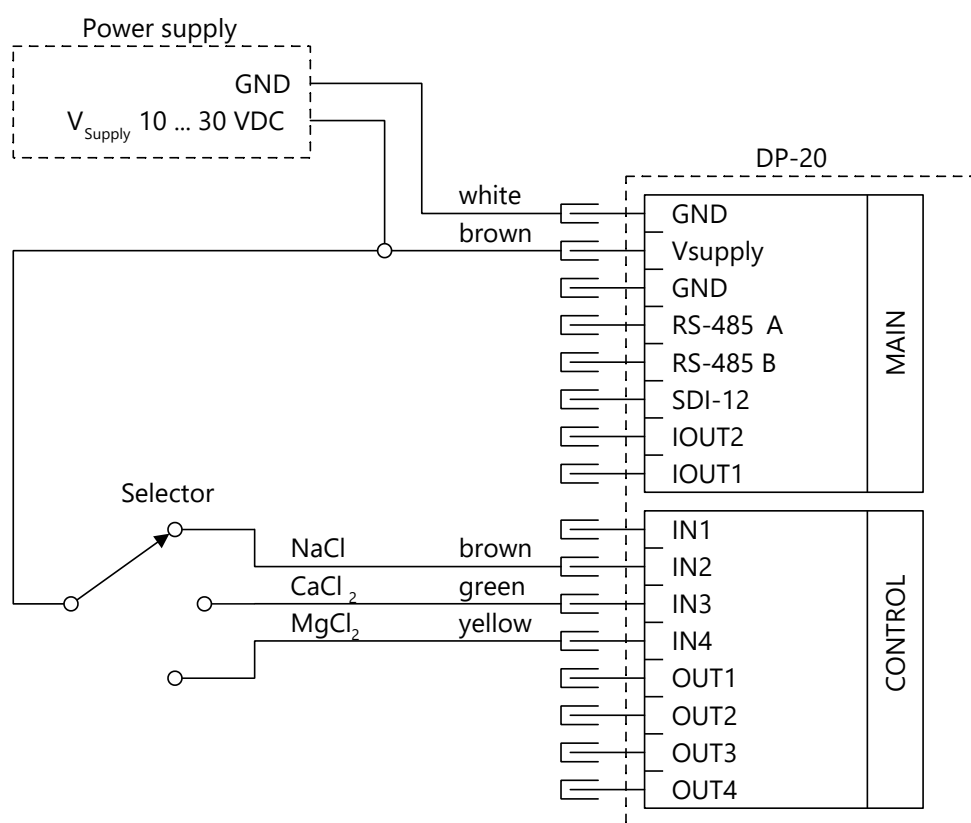

8.5 How to change the set point

8.5.1 With the LC-Display MD-10

Enter into the settings mode, navigate to **Set point** and enter the value of the required **Set point** and the **Range +/-** within the solute concentration may vary.

8.5.2 With the Commander

1. In the parameter menu **Medium settings** open the sub-menu of the required medium, e.g. **NaCl settings**.
2. Change **Set point** to the desired value.
3. Provide a **Set point range** within the solute concentration may vary.



TIP Provide a **Minimum set point** and **Maximum set point**. These two settings restrict the concentration range that can be entered over the LC-Display MD-10. If a value outside this range is entered, the value is set to the minimum or maximum value.

8.5.3 By Modbus

Write the set point of the solute concentration of the required medium to the following holding register address:

- **103** for NaCl
- **104** for CaCl₂
- **105** for MgCl₂
- **106** for custom medium

8.6 How to add a custom medium

8.6.1 With the LC-Display MD-10

Enter into the settings mode, navigate to **Medium** and select **Custom**.

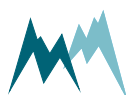



NOTE A custom medium has to be defined in the Commander as described below.

8.6.2 With the Commander

A custom medium is defined by a table that contains the density values for a defined range of solute concentrations and temperatures. Follow the steps below to build such a table.

1. In the parameter menu navigate to **Medium settings** and **Custom medium settings**.
2. Name your medium in **Medium name**.
3. In the sub menu **User tables** enter the number of temperature and concentration values that define the size and resolution of the look-up table.
4. In **Temperature table** enter the temperature values of your density table.
5. In **Concentration table** enter the solute concentration values of your density table.
6. Enter the density values in the Density table as integer number in $\mu\text{g}/\text{cm}^3$, which corresponds to g/m^3 . The table below gives an example.
7. Upload all changes to the DP-20.

	Density [$\mu\text{g}/\text{cm}^3$]								
T [°C]	1	2	4	6	8	10	12	14	16
0	1007470	1015090	1030380	1045750	1061210	1076770	1092440	1108240	1124190
10	1007070	1014420	1029200	1044080	1059070	1074190	1089460	1104910	1120560
20	1005340	1012460	1026800	1041270	1055890	1070680	1085660	1100850	1116210
25	1004090	1011120	1025300	1039630	1054120	1068790	1083650	1098720	1114010
30	1002610	1009570	1023610	1037810	1052190	1066760	1081530	1096510	1111710
40	999080	1005930	1019770	1033780	1047980	1062380	1076990	1091820	1106880
50	994820	1001610	1015310	1029190	1043260	1057530	1072020	1086740	1101700
60	990000	996700	1010300	1024100	1038100	1052300	1066700	1081300	1096200

8.7 How to activate mixing control

1. For easy operation, wire a switch to the IN1 input of the CONTROL connector as illustrated below. By closing the switch the DP-20 activates the mixing control.

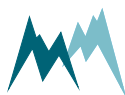

2. Add two control relays to the switch outputs OUT1 and OUT2. These relays switch your medium flows by solenoid valves, operating relays, etc.
3. Open the parameter menu in the Commander and adapt the controller settings in the sub menu **Technics > Mixer controller**.
4. In the sub menu **Medium settings** enter the set point of the required solute concentration.
5. After all equipment has been installed and wired properly close the switch and check if the solute concentration reaches the set point in due time. if required, adjust the controller settings.

The mixing control can also be activated by writing **1** to the Modbus holding register address **102**. To deactivate write **2**.

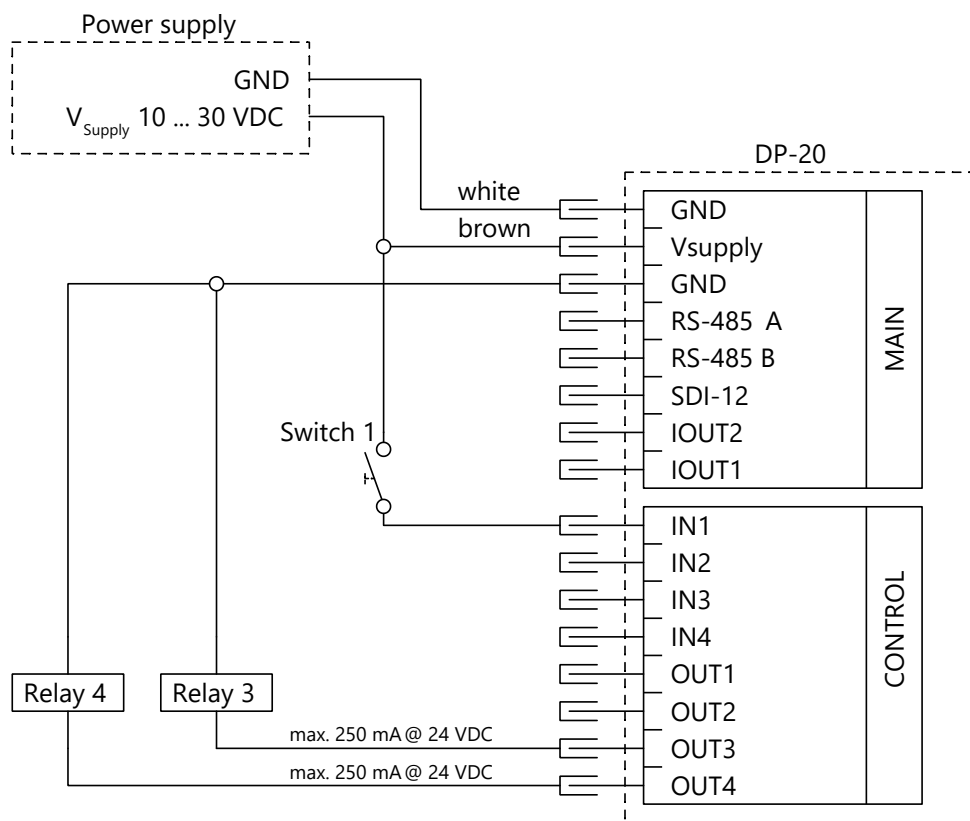

9 Maintenance

The DP-20 generally does not require any special maintenance.

Whenever the medium is changed or the DP-20 is put out of operation, the U-tube should be thoroughly rinsed with clean water. To remove any deposits diluted citric, acetic or any other weak, food safe acid may be added to the rinsing water.

Store the DP-20 drained or filled with clean water.

Occasionally connect the DP-20 to a clean water flow. If the measured density deviates more than approx. $\pm 3\%$ from the water density, send the unit to Sommer Messtechnik for recalibration.

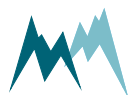

10 Support software Commander

10.1 Software features

The Commander is a multipurpose software tool to configure and operate any Sommer Messtechnik device. It offers the following functions:

- Communication with Sommer Messtechnik sensors and data loggers via serial connection, modem, socket, IP-call and Bluetooth®
- Management of connections and stations
- Configurations of sensors and data loggers
- Live data monitoring and storage
- Data management including download from data loggers and transmission to MDS (Measurement Data server)
- Terminal window to check data transfer and to access device settings directly

10.2 System requirements

The Commander software supports 32- and 64-bit versions of Windows 7 SP1, Windows 8, Windows 8.1, Windows 10 and Windows 11.

For correct operation Microsoft® .NET Framework 4.5 or later must be installed.

10.3 Installation of Commander

Follow the steps below to install the Commander software:

1. Plug the USB stick shipped with the device into your PC.
2. Double-click the [commander.msi](#) installer file on the USB drive.

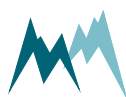

3. Click **Next** on the pop-up window



4. Read the instructions and click **Next**

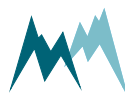
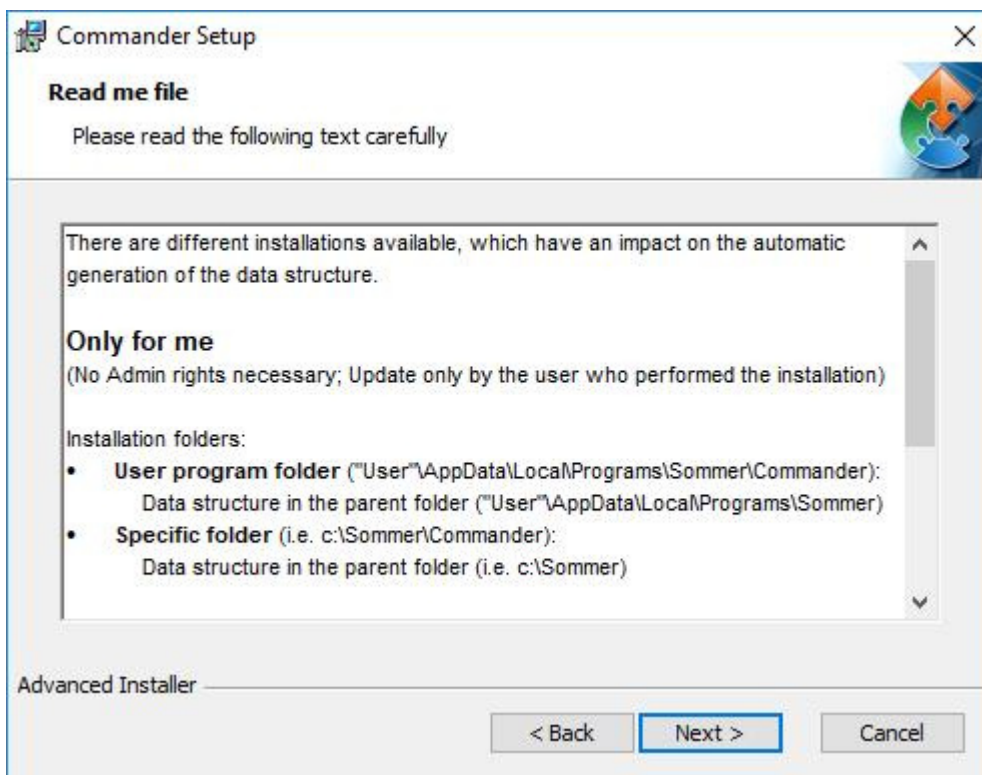

5. Select the installation type and click **Next**

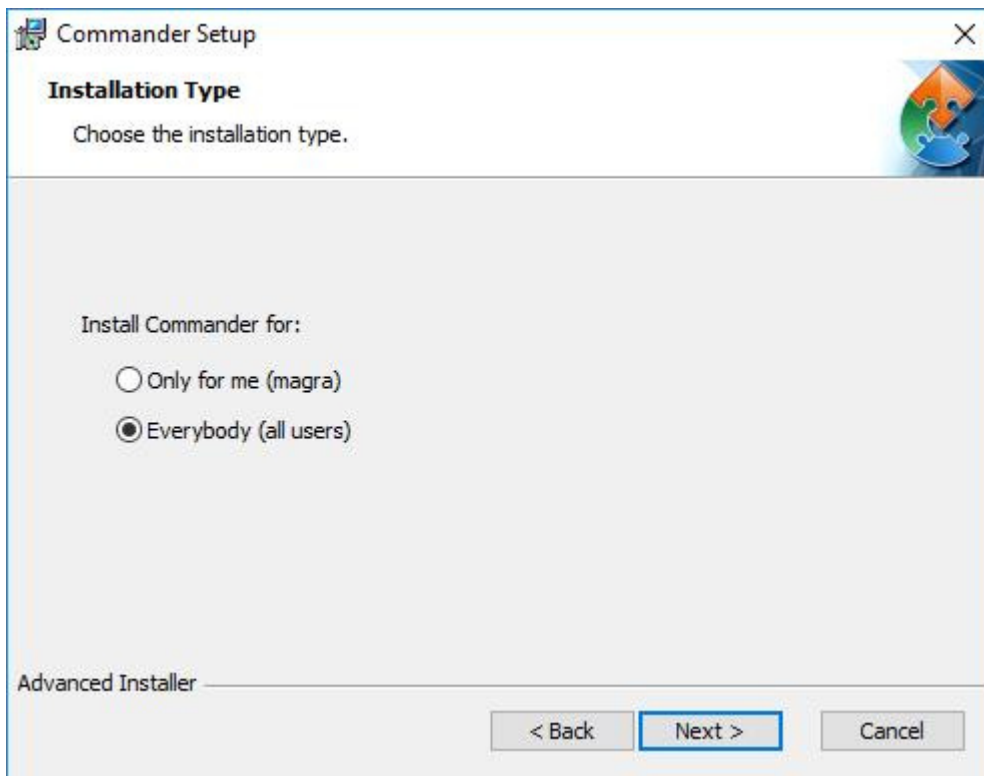

NOTE

Two installation types are available. Depending on the selection, the access rights and the folder structure differ:

Only for me

No admin rights are required. Updates are only available to the user who installed the software.

Installation folders:

- User program folder:
Users\User\AppData\Local\Programs\Sommer\Commander
Data structure:
Users\User\AppData\Local\Programs\Sommer
- Specific folder (default):
C:\Sommer\Commander
Data structure (default):
C:\Sommer

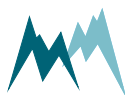



Everybody

Admin rights are required. Updates may only be performed by system administrators.

Installation folders:

- Standard program folder:
Program Files (x86)\Sommer\Commander
Data structure:
Users\Public\Public documents\Sommer
- Specific folder (default):
C:\Sommer\Commander
Data structure (default):
C:\Sommer

6. Select the installation directory and click **Next**

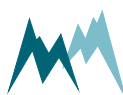
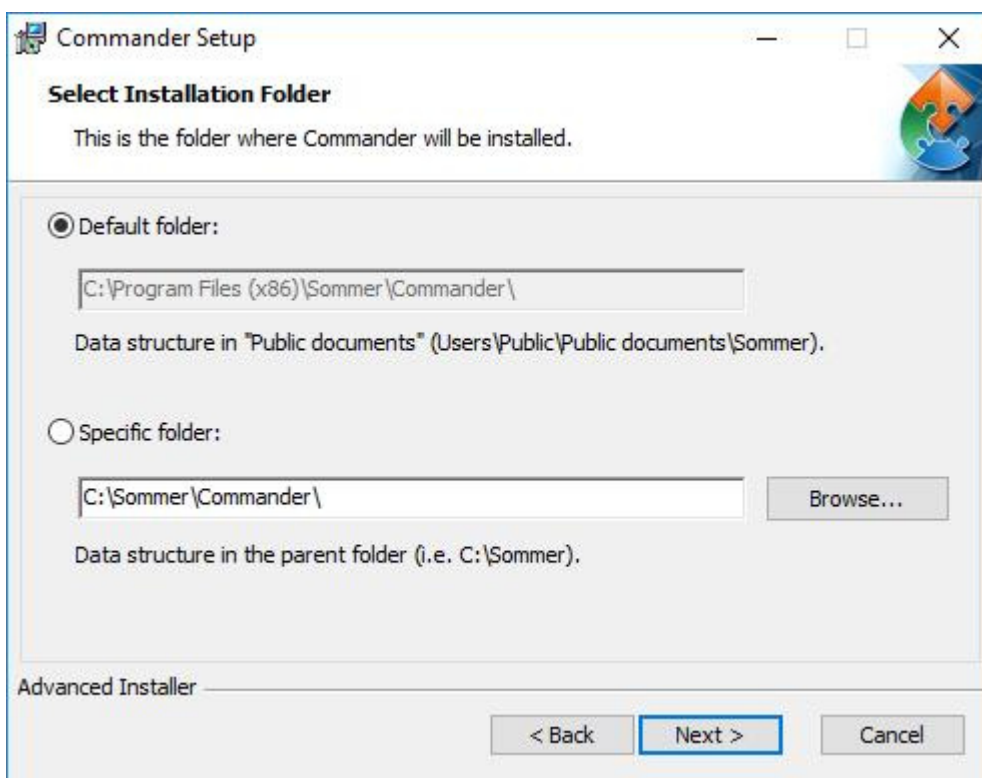

7. Select the features to be installed and click **Next**

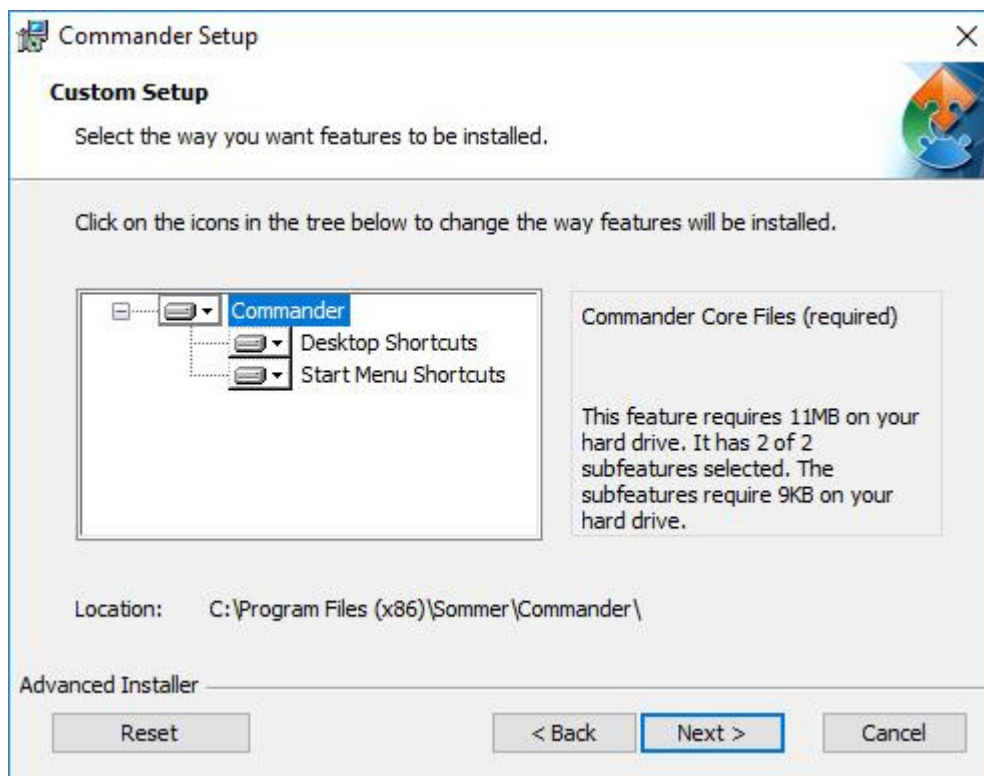

8. Click **Install** to start the installation.

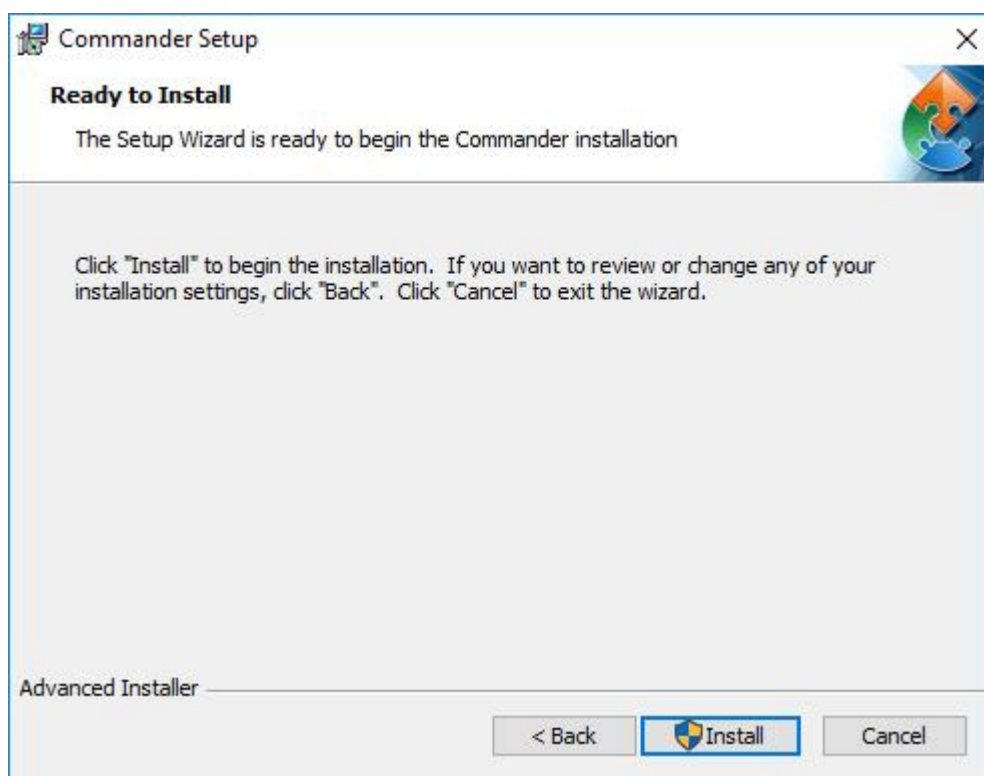

9. Click **Finish** to complete the installation.

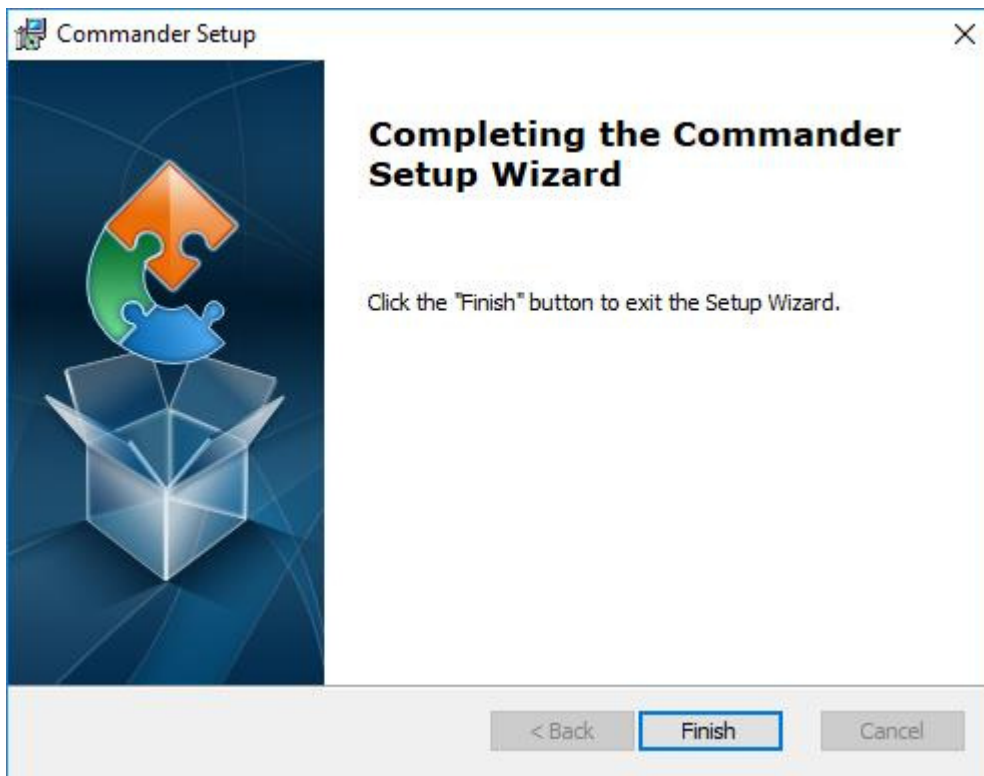

10.4 Change authorization

To prevent unintended changes of parameters in the **Technics** menu authorization is generally set to **Normal**. Parameter modifications in **Technics** are enabled by switching the authorization level to **Expert** as described below:

1. On the upper tab bar click on **Options** and select **Common**.
2. In the Options window select authorization **Expert** and click **OK**.

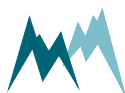
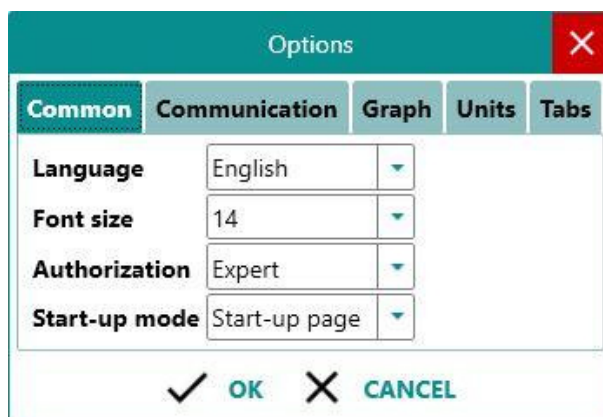

10.5 Working with connections

10.5.1 Establish a connection with the Communication assistant

1. Install the Commander support software as described in [Installation of Commander](#).
2. Connect the device to your PC.
3. Start the Commander software on your PC.
4. Click on **Communication assistant** on the right-hand side of the Commander window and follow the instructions. During this procedure the communication assistant will search for connected devices. Upon successful completion, the new connection is added to the connections list (tab **Connections (F8)**). See also pictures steps 1 to 8 in [Create a station with the Communication assistant](#).
5. In the **Communication** section at the right-hand side of the Commander window select **Mode Connection** and the previously created connection from the drop-down list.
6. Click **Connect** to establish a connection with the DP-20. If the connection was successful a green icon is displayed at the top-right corner of the Commander window.

To view the settings of the connected device or to read the current measurements, follow the steps described in [Download setup](#) and [Record measurements](#).

10.5.2 Establish a connection manually

1. Install the Commander support software as described in [Installation of Commander](#).
2. Connect the device to your PC.
3. Start the Commander software on your PC.
4. Select the required connection in the **Connections** list of the **Connections (F8)** tab and click **Connect**. If the connection was successful a green icon is displayed at the top-right corner of the Commander window.

If you don't have the required connection available in the **Connections** list, create a new connection as described in [Create a new connection](#).

To view the settings of the connected device or to read the current measurements, follow the steps described in [Download setup](#) and [Record measurements](#).

10.5.3 Create a new connection

1. Select the **Connections (F8)** tab in the Commander. If the tab is not shown, select it with pressing **F8**.
2. Click **New connection**.

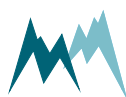

3. In the section **Connection settings** enter a name of the new connection, e.g. *Serial-com1-9600*, and the connection type, e.g. *Serial connection*.
4. Enter the required information for the selected connection type.
If your DP-20 is wired to your PC with a RS-485 to USB converter cable, select the port where the device is connected and select a Baud rate of 9800.

10.6 Working with stations

10.6.1 Create a station with the Communication assistant

In order to manage several data loggers, to connect to a data logger via IP-call and to download data, stations can be created in the Commander software. To view a list of all stations select the tab **Stations (F7)**. If the tab is not shown, select it with pressing **F7**.

Perform the following steps to create a new station with the **Communication assistant**:

1. Click on **Communication assistant** in the Commander-window

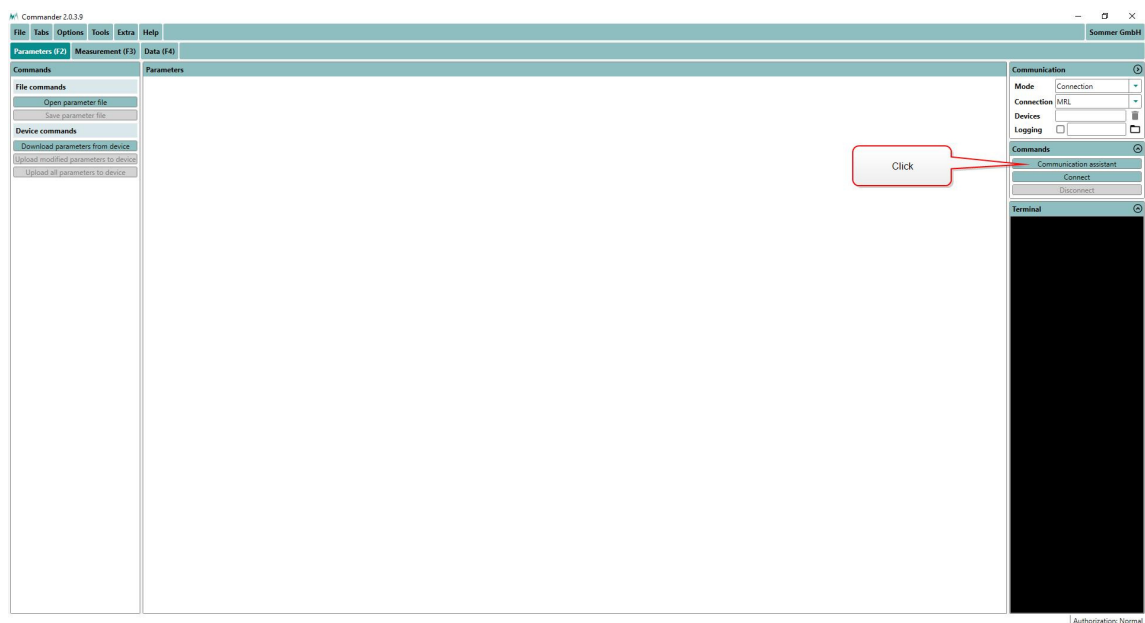

2. In the pop-up window choose the required connection and click [Next](#).

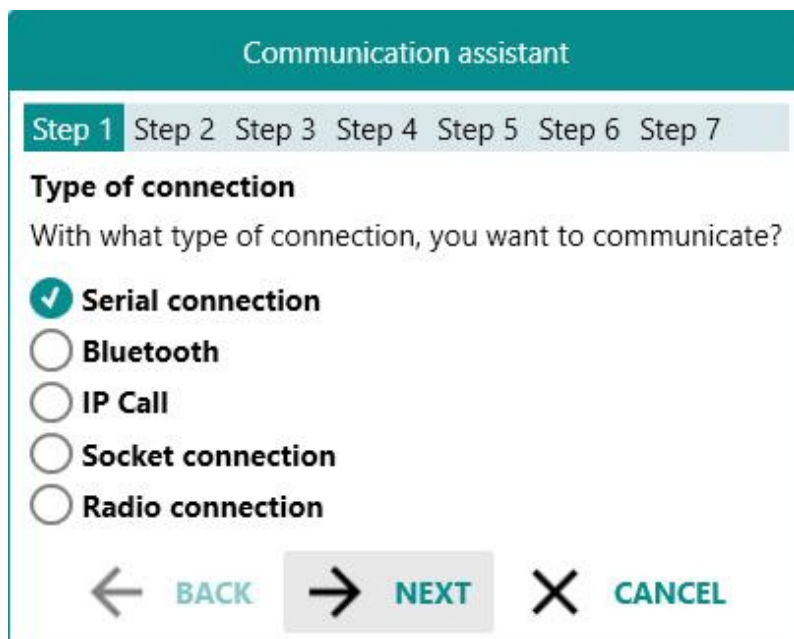

Communication assistant

Step 1 Step 2 Step 3 Step 4 Step 5 Step 6 Step 7

Type of connection

With what type of connection, you want to communicate?

Serial connection

Bluetooth

IP Call

Socket connection

Radio connection

← **BACK** → **NEXT** ✕ **CANCEL**

3. Verify that the DP-20 is connected to your PC and a power supply. Click [Next](#).



Communication assistant

Step 1 **Step 2** Step 3 Step 4 Step 5 Step 6 Step 7

Serial connection: Device fully functional?

Make sure that the device is connected and supplied.
Click "Next" to proceed.

← **BACK** → **NEXT** ✕ **CANCEL**

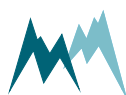

4. Select *Logger (115200 Bd)* and click *Next*.

Communication assistant

Step 1 Step 2 Step 3 Step 4 Step 5 Step 6 Step 7

Serial connection: Device type
 With what type of device, you want to communicate?

Logger (115200 Bd) (MRL-6, MRL-7, RQ-30 ADMS)

Sensor (9600 Bd) (RQ-30, RG-30, SQ-X, SQ-X, SV-a)

Modbus (19200 Bd) (Only for devices set to Modbus)

Or should a port be checked with changing settings?

Check port Baud rate, Parity and stop bits

← BACK → NEXT × CANCEL

5. Select *Scan ports* and click *Next*.

Communication assistant

Step 1 Step 2 Step 3 Step 4 Step 5 Step 6 Step 7 Step 8 Step 9

Serial connection: Connection
 Do you want to communicate with an existing or new connection?

Baud rate 9600

Existing connection

Connection ▼

New connection

Select port ▼

Scan ports

← BACK → NEXT × CANCEL

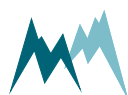

- The Commander now scans all available ports.

Communication assistant

Step 1 Step 2 Step 3 Step 4 **Step 5** Step 6 Step 7 Step 8 Step 9

Serial connection: Scan device

All available serial ports are sequentially scanned for a device.
When the first device is found, the procedure is stopped.

Scan ports

Switch-on standard mode

5/7

Repeat: 5/5



← BACK → NEXT ✕ CANCEL

- Adopt the *Name* provided by the communication assistant. Click *Next*.

Communication assistant

Step 1 Step 2 Step 3 Step 4 Step 5 **Step 6** Step 7 Step 8 Step 9

Serial connection: New connection

A device has been detected with the connection.
The connection is created.

Name

Type Serial connection

Port

Baud rate 115200

← BACK → NEXT ✕ CANCEL

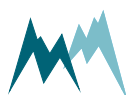

8. The Commander now scans the selected port for connected devices.

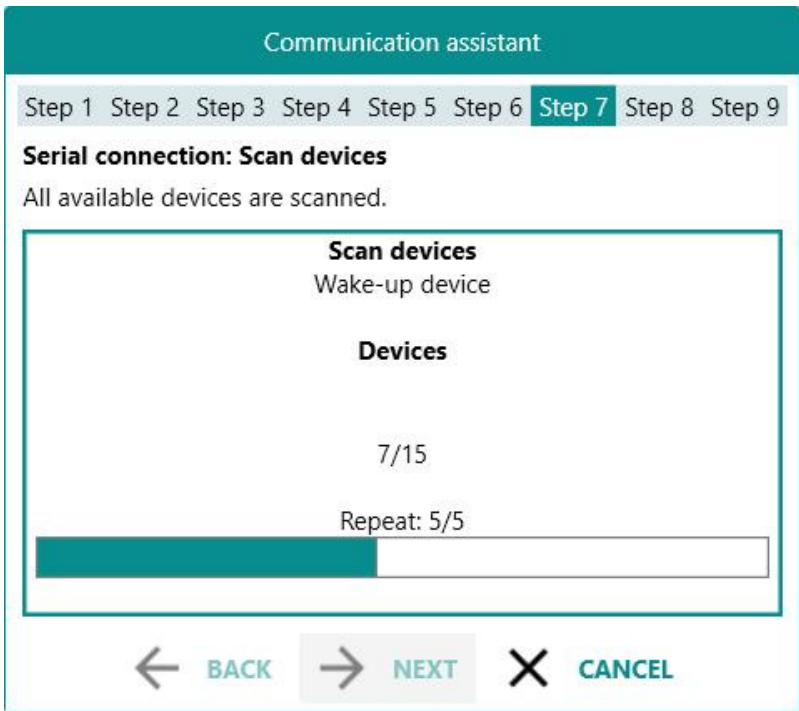

9. Adopt the *Name* of the new station or enter a new name. Click *Next*.

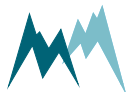
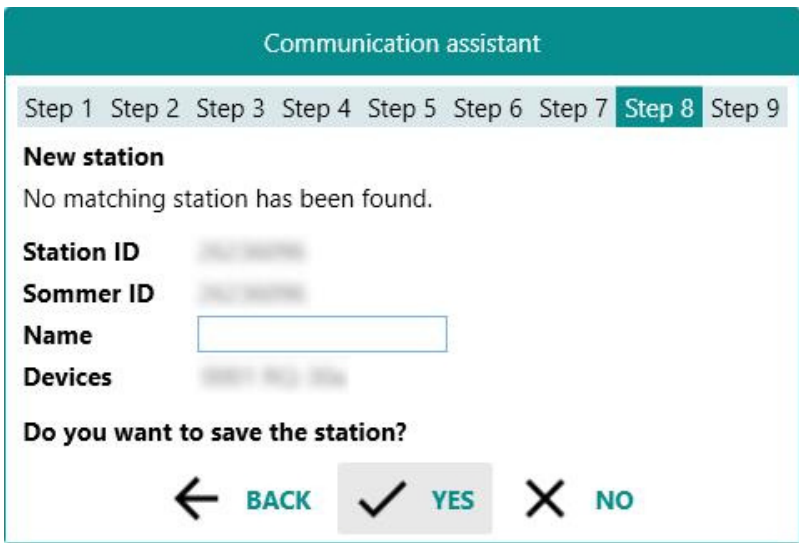

10. A new station has now been created. Click **Finish**.

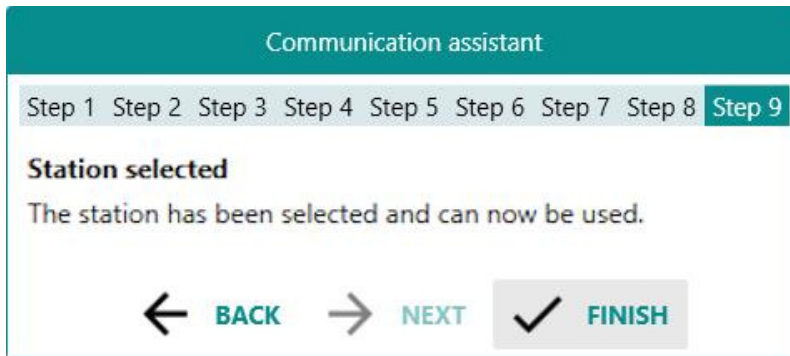

11. The newly created station can now be selected in the **Communication** section of the Commander. Click **Connect** to activate the connection to your device.

10.6.2 Create a station manually

In order to manage several data loggers, to connect to a data logger via IP-call and to download data, stations can be created in the Commander software. To view a list of all stations select the tab **Stations (F7)**.

Perform the following steps to create a new station:

1. In the tab-menu **Stations (F7)** click **New station**.
2. Under **Station settings** enter the **Station number** and **Sommer ID**. By default both settings are set to the device's serial number (visible on the DP-20 housing).
3. Select the **Connections** used for the station. Multiple selections are possible; the default connection can be selected by ticking the circular field.
4. Depending on the connection type, enter the additional information, e.g. **Address** for a Bluetooth connection or **IMSI number** for an IP call.
5. Enter the settings for **Data** management. When data are downloaded from a connected DP-20 they are stored in an archive-file by default. Each archive-file contains the data of a year or month, as selected in **Archive type**. Selection **None** will save all data in one file. The default location for data files is C:\Users\Public\Documents\Sommer\Data\.
6. Save the newly created station with the button **Save station**.

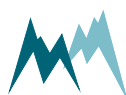

10.7 Working with measurements

10.7.1 Poll continuous measurements

1. Establish a connection to your device as described in [Working with connections](#).
2. Download the setup of your device as described in [Download setup](#).
3. Select the [Measurement \(F3\)](#) tab.
4. In the [Commands](#) section click [Start polling measurement](#).
5. Select the option [Polling with measurements](#). Now, the Commander will trigger measurements of the DP-20 without any delays between measurements. The results are displayed [Measurement values](#) and plotted in the [Measurement data graph](#).
6. To finish polling mode click [Stop polling](#).

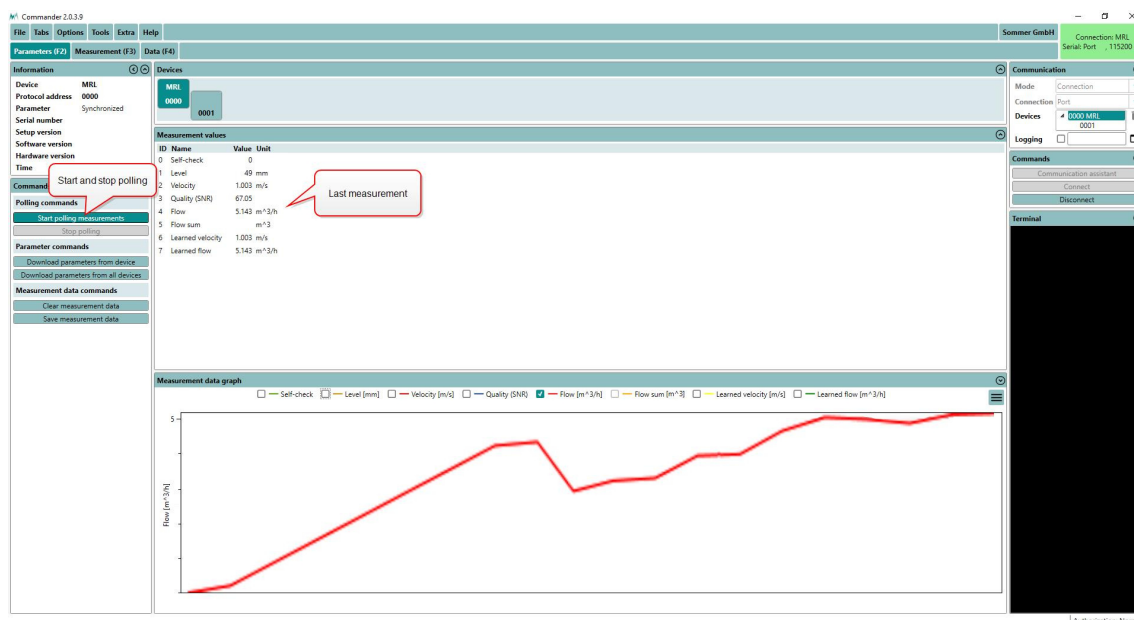

NOTE The polling mode stops automatically after 30 minutes.

10.7.2 Record measurements

1. Establish a connection to your device as described in [Working with connections](#).
2. Download the setup of your device as described in [Download setup](#).
3. Select the [Measurement \(F3\)](#) tab.
4. Make sure that [Measurement output](#) is set to [Measured values push](#) or [Storage values push](#).

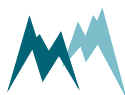

5. If the connection with your device is active, the data will now be displayed in the measurement table and updated at the interval specified in the setup. Also, the incoming data strings are displayed in the [Terminal](#).
6. Click [Save measurement data](#) in the [Commands](#) section to save the recorded measurements. The data are saved as a *.csv file in the SommerXF format.



NOTE You can change the scope of the data output in the setup [Information](#).

10.8 Working with data

10.8.1 View live data

Follow the steps below to view live data acquired from your device:

1. Establish a direct or remote connection with the DP-20 using the Commander. Use an existing Commander-connection or -station if available.
2. In the [Parameters \(F2\)](#) tab download the parameters of the DP-20.
3. Now, there are two options to view the measurement data:
 1. If [Measurement output](#) is set to *Measured values push* or *Storage values push*, data are displayed in the [Measurement \(F3\)](#) tab in the specified measurement interval.
 2. Open the [Measurement \(F3\)](#) tab and click [Start polling measurements](#). This measurement mode can be stopped by clicking [Stop polling](#), or it is finished automatically after 30 minutes.

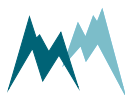
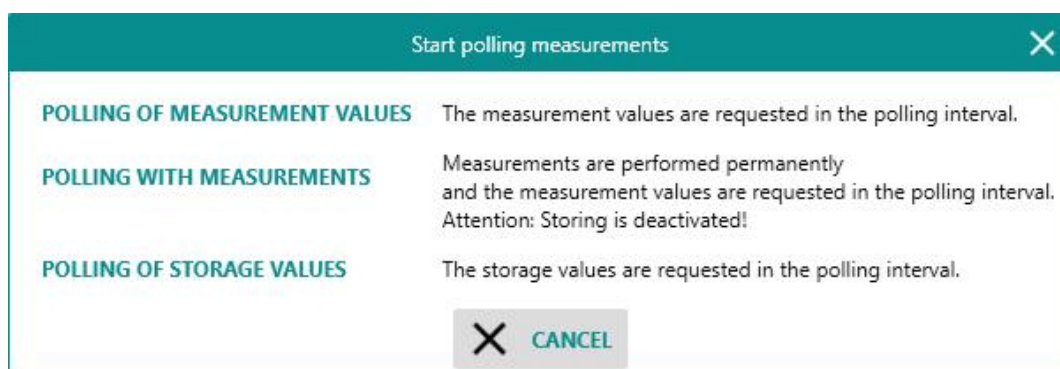

10.9 Working with setups

10.9.1 Download setup

1. Establish a connection to your device as described in [Working with connections](#).
2. Select the [Parameters \(F2\)](#) tab in the Commander software.
3. In the [Commands](#) section click [Download parameters from device](#).

The Commander now downloads the setup currently active on the DP-20. This may take some time if you are downloading the setup for the first time to your PC. Consecutive downloads of a setup with the same version number will be faster as the parameter structure is already available.

You can now save the setup file by clicking [Save parameter file](#), or edit the settings as described in [Edit setup](#).



TIP Save the setup on your PC before you make any changes!

10.9.2 Open a setup file

1. Start the Commander on your PC and connect to your DP-20 directly with the USB to RS485 isolated converter cable.
2. Open the [Parameters \(F2\)](#) tab and click [Open parameter file](#). Select the required file (extension .xml or .xmla).
3. Verify the new settings and click [Upload all parameters to device](#). After completion the new settings are active on your data logger.

10.9.3 Edit setup

1. Open the setup file as described in [Open a setup file](#) or download it from your device as described in [Download setup](#).
2. Adapt the values of the settings in question and press Enter after each. After you have changed a value, its text box will turn red.



NOTE If you have entered a value outside the data range of the setting, it will be forced to the next valid value! The valid range of each setting is listed in the [Parameter definitions](#).

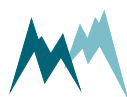

3. After you have adapted all required settings save the setup file and/or upload the setup to your device by clicking [Upload modified parameters to device](#).
Once the setup has been saved or uploaded, the modified red text boxes will turn white again, indicating that the settings have been saved/applied.

10.9.4 Upload new setup file

1. Establish a connection to your device as described in [Working with connections](#).
2. Select the [Parameters \(F2\)](#) tab.
3. Download the setup currently on the DP-20 as described in [Download setup](#) and save it by clicking [Save parameter file](#). This step is recommended to have the latest setup available for documentation.
4. Click [Open parameter file](#) and select the required setup file (*.xlm) on your PC.
5. Click [Upload all parameters to device](#). This transfers the current setup to the DP-20.
6. To verify the correct upload click [Download parameters from device](#). This will display the present setup of the DP-20.

10.10 Update firmware

1. Connect the DP-20 to your PC with the USB to RS485 isolated converter cable.
2. Make sure no connection is active in the Commander (no green icon at the top-right corner).
3. Click on the menu item [Extra](#) and select [Start Programmer](#).
4. Select the firmware file (*.hex) provided by SOMMER Messtechnik. Make sure the file is stored on your PC and not on a USB or network drive.
5. Choose the COM-port the data logger is connected to and a Baud-rate of 57'600.
6. Perform the following three steps in short sequence:
 - Click [Program](#)
 - Unpower the data logger
 - Wait 3...5 seconds to enable full activation of the bootloader and a correct restart (capacitors must be discharged, and if the device had been in sleep mode, this can take some time)
 - Repower the data logger

The firmware currently present on the data logger is now erased and the new one copied to the data logger. During the update process the pop-up window may show the following messages:

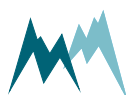

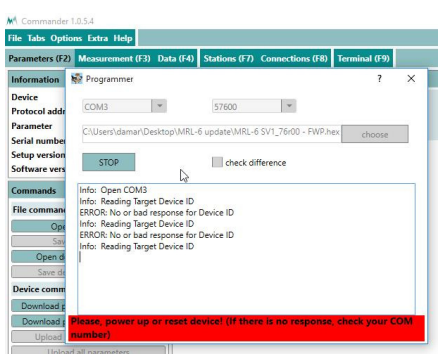

The device is not ready; power needs to be on.

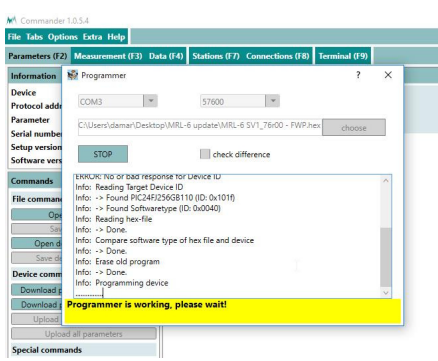

The programmer is active.

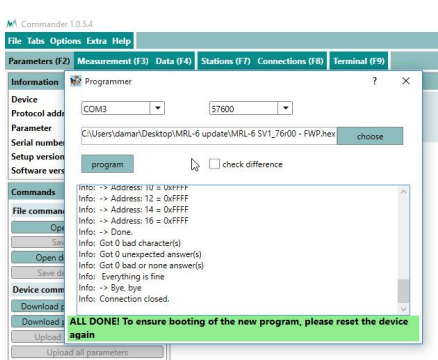

The firmware update has finished.

7. Close the programmer-window as soon as the firmware update has finished.
8. Switch off and repower the data logger again.
9. Open the **Parameters (F2)** tab.
10. Click **Download parameters from device**. The download of the new parameter list might take a few minutes as the parameter structure may need to be downloaded as well. After completion the new firmware and setup versions will be displayed in the **Information** section.

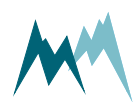

11 Configuration of the DP-20

11.1 Software tools

The DP-20 can be configured with one of the following tools:

- Configuration with Commander support software
- Configuration with a terminal program (also included in Commander)
- LC-Display MD-10 (allows configuration of daily used settings)

11.2 Configuration with Commander support software

Follow the steps below to modify the configuration parameters of the DP-20:

1. Establish a connection between your PC and the DP-20.
2. Click **Download parameters from device**. The complete parameter list is transferred from the DP-20 to your PC and displayed in the Parameter window.

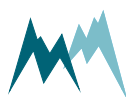
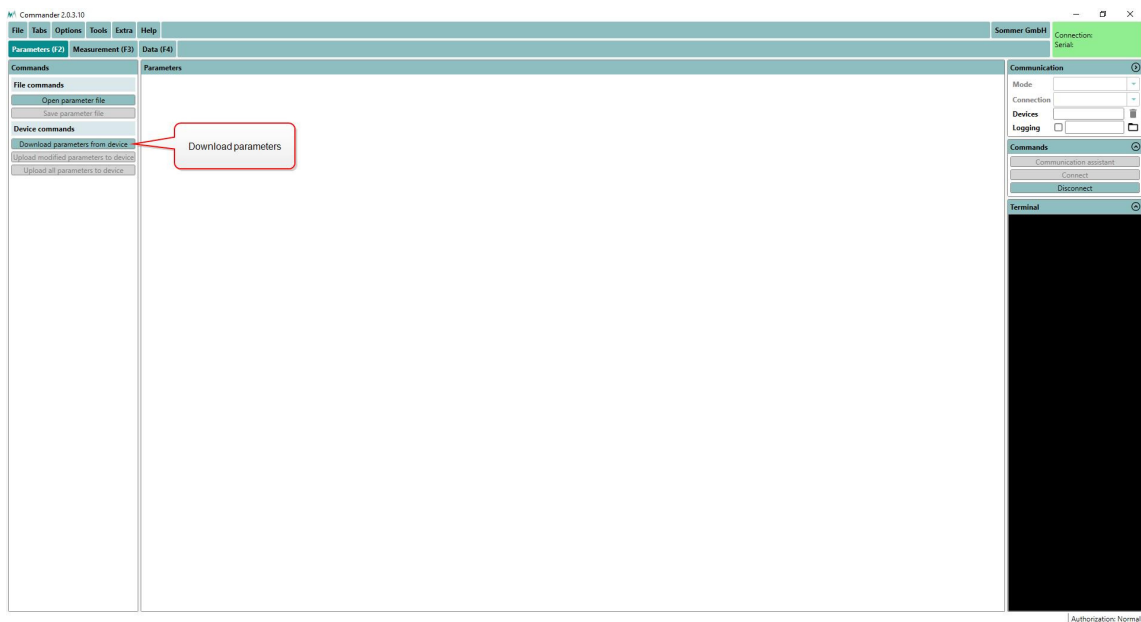



NOTE The first download of the parameter list may take a few minutes. After that the device is known to the PC and consecutive downloads are much faster.



3. Save the parameter file to your PC by clicking **Save parameter file**. This step is recommended to track any configuration changes.

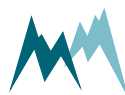
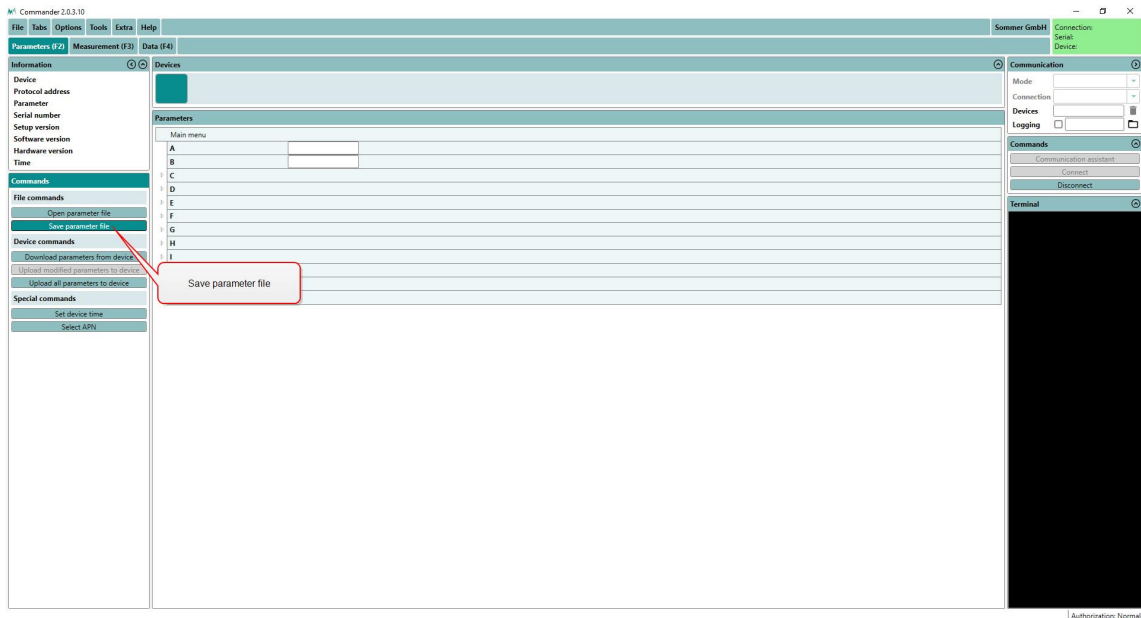

4. Adapt the parameters required for your application. Changed values are displayed with a pink background.

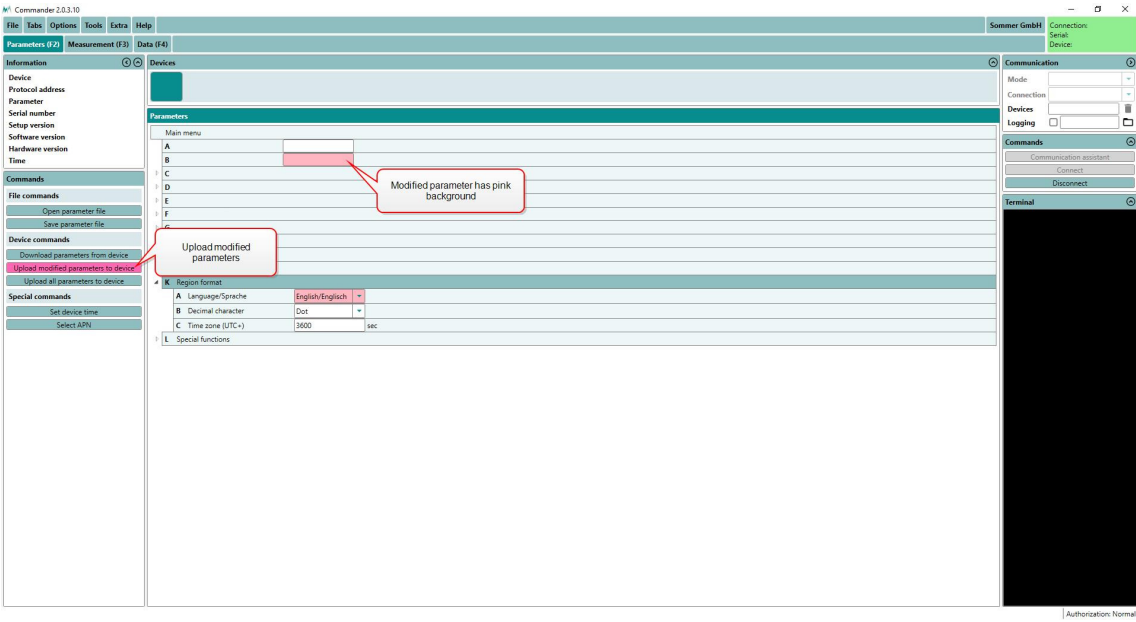

5. Send the modifications to the DP-20 by clicking **Upload modified parameters to device**. Upon successful upload the pink backgrounds disappear again.

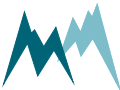

11.3 Configuration with a terminal program

The Commander software ships with an integrated terminal program. However, communication with the DP-20 can be performed with any terminal program.

Follow the steps below to modify the configuration parameters of the DP-20:

1. Establish a connection between your PC and the DP-20.
2. In the terminal window enter three question marks (???) in quick succession. The main parameter menu is displayed in response.

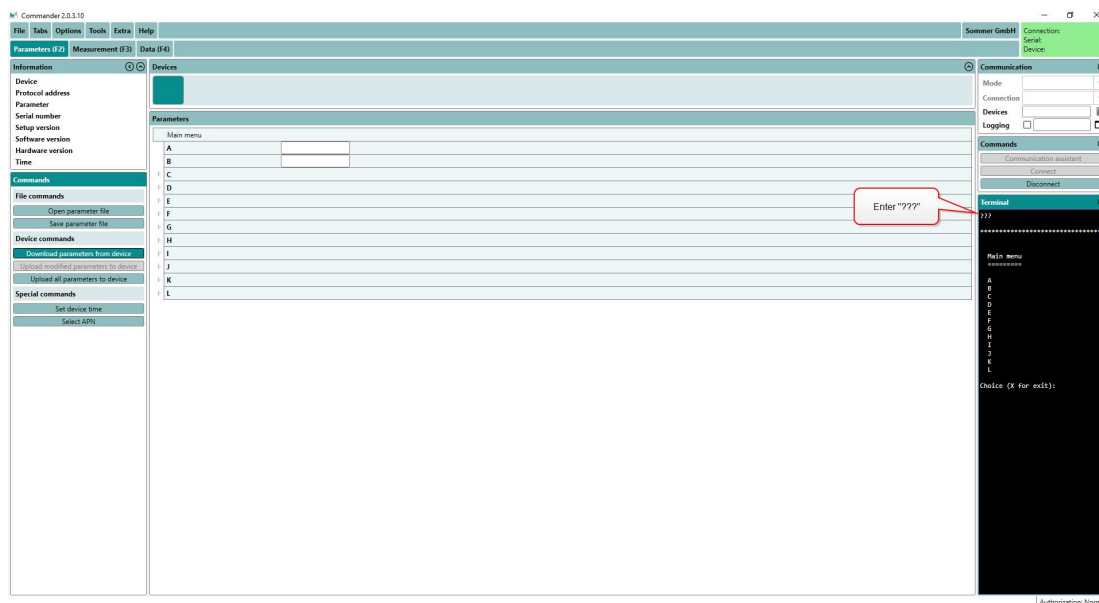

NOTE As an unwanted switching into the menu mode must be avoided the timing of the three question marks ??? is very restrictive and must never be finished with Return/Enter. This is especially important for command line tools, which automatically send a closing "Carriage return". Before and after sending ??? no communication must occur for 1 second.

3. Read or modify the required parameters: The menu items can be selected by entering the letter assigned to each item. Upon selection a submenu is opened or the selected parameter is displayed with its unit. Changes to values are confirmed with **Return/Enter** or discarded with **Esc**. Menus are closed with **X** or **Esc**. After closing the main menu with **X** the device performs an initialization.

The screenshot shows the Commander 2.0.3.10 software interface. The main window is titled 'Commander 2.0.3.10' and has a menu bar with 'File', 'Tabs', 'Options', 'Tools', 'Extras', and 'Help'. Below the menu bar are three tabs: 'Parameters (F2)', 'Measurement (F3)', and 'Data (F4)'. The 'Parameters' tab is active, showing a 'Main menu' with options A through L. A red callout box points to option 'K' in the menu, with the text: 'In this example the language is changed to English. To do so, enter the letter "K" to get into "Region format", then the letter "a" for "adjustment of Language" and then "2" for English.'

On the right side of the interface, there is a 'Terminal' window showing the following text:

```

Main menu
-----
A
B
C
D
E
F
G
H
I
J
K
L

Choice (X for exit): K

Region format
-----
a language/Sprache .....
b DecMal character .....
c time zone (UTC) .....

Choice (X for exit): a

adjustment of "A language/Sprache"
-----
1 = German/Deutsch
2 = English/Englisch

(Press "Esc" to cancel)
(Press "RETURN" to assume)

Choice of option= 2
    
```

At the bottom right of the terminal window, the text 'Authorization Normal' is visible.

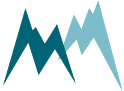

12 Communication

12.1 Communication protocols

The DP-20 provides the following communication protocols:

- [RS-485](#) (Sommer Bus Protocol)
- [Modbus](#)
- [SDI-12](#)

12.2 Data output

The measurement values returned by the DP-20 are arranged in a fixed sequence and identified by an index. They are divided into three groups and can be selected in [Information](#).

12.2.1 Main values

Index	Measurement value	Unit	Description
1	Temp. medium	°C	Medium temperature
2	Density	g/cm ³	Medium density
3	Concentration	%	Solute concentration by mass
4	Set-point	%	Set-point of solute concentration by mass
5	Status	-	Configuration and status of measurement (see Measurement status)

Table 2 Main values

12.2.2 Measurement status

After each measurement a 7-digit status value is returned. The digits are defined as follows (also see examples below):



Digit	Value	Description
000000x bit-coded*	0 1 2 4	Digital inputs IN2, IN3 and IN4 are inactive. Digital input IN2 (NaCl) is active. Digital input IN3 (CaCl ₂) is active. Digital input IN4 (MgCl ₂) is active.
00000x0	0 1 2 3 4 5	No medium is selected. NaCl solution is selected. CaCl ₂ solution is selected. MgCl ₂ solution is selected. Custom medium is selected. Medium is selected by external switch.
0000x00 bit-coded*	0 1 2 4	The signals of the oscillating U-tube and the PLL** -controller are out of phase, i.e. device is not ready for measurements. Phase of the oscillating U-tube signal matches the phase of the PLL** -controller signal. Density measurement is OK. Concentration is out of range.
000x000 bit-coded*	0 1 2 4	DP-20 has no mixing controller. DP-20 is equipped with a mixing controller. Mixing is active. Digital input IN1 (mixing control by DP-20) is active.
00x0000 bit-coded*	0 1 2 4	Temperature unit is °C and adjustment is inactive. Temperature unit is F. Adjustment is active. Not used
0x00000 bit-coded*	0 1 2 4	No medium or temperature error is detected. Error medium Error temperature Not used
x000000	0 ... 9	Quality indicator where: 0: PLL** control operates perfectly, 1 ... 2: PLL control is good, 3 ... 5: PLL control is satisfactory, 6 ... 7: PLL control may be acceptable, 8 ... 9: PLL control is poor or inactive (medium contains air bubbles or suspended solids).

*Combined values can be displayed, e.g., if values 1 and 2 are active, 3 is displayed.

**Phase-locked loop



EXAMPLE

Measurement status of a DP-20 that is not ready: 9201022

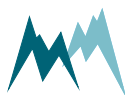



- 9 PLL-control is bad
- 2 Temperature error
- 0 Temperature unit is °C
- 1 DP-20 has a mixing controller
- 0 Device not ready (signals out of phase)
- 2 CaCl₂ solution is selected.
- 2 Digital input IN3 (CaCl₂) is active.

**EXAMPLE**

Measurement status of a DP-20 operating regularly: 0001322

- 0 PLL-control is OK.
- 0 No error
- 0 Temperature unit is °C.
- 1 DP-20 has a mixing controller.
- 3 Oscillator and controller signals are in phase and density measurement is OK.
- 2 CaCl₂ solution is selected.
- 2 Digital input IN3 (CaCl₂) is active.

12.2.3 Exception values

Measurement data may be returned with the following exception values:

Value	Description
99999998	Initial value: No measurement has been performed yet.
99999997	Conversion error: Caused by a technical problem.
99999999	Positive overflow
-99999999	Negative overflow

Table 3 Exception values

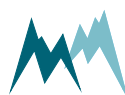

12.3 RS-485

12.3.1 What is RS-485?

RS-485 is a serial communication method for computers and devices. It is currently a widely used communication interface in data acquisition and control applications where multiple nodes communicate with each other.¹

12.3.2 What can I do with it?

RS-485 communication is primarily used to trigger measurements and read their results. It also permits to change parameters of the DP-20.

12.3.3 Configuration

The DP-20 has serial RS-485 communication enabled by default. If the device is integrated into a RS-485 network or connected to a stand-alone data acquisition system, e.g. a data logger, the parameters listed in [RS-485-1 Protocol](#) may need to be adapted.

12.3.3.1 System key and device number

The system key and device number are used to identify a DP-20 in a bus system. This is essential if multiple devices (DP-20 and data loggers) are operated within the same system.

System key

The system key separates different conceptual bus systems. This may be necessary if the remote radio coverage of two measurement systems overlap. In wired setups, the system key should be set to *00*.

Device number

The device number is a unique number that identifies a device in a bus system.



ATTENTION Do not use a device number twice in your bus system! Otherwise communication will fail!

¹<https://www.lammertbies.nl/comm/info/RS-485.html>

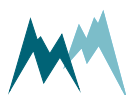

12.3.3.2 Measurement output

The serial data output can be triggered in the following ways:

ID	Option	Description
1	just per command	The output is only requested by commands via the RS-485 or SDI-12 interface.
2	after measurement (default)	The serial data output is performed automatically right after each measurement.



NOTE If **Measurement output** is set to *pos. TRIG slope*, the data are returned with a delay of 200 ms after the trigger has been set. Make sure that your data acquisition system takes account of this lag to ensure that it receives the most recent data.

12.3.3.3 Operation modes

The selected combination of measurement trigger and output time determines the following operation modes:

Parameter	Mode		
	Pushing	Polling	Apparent polling
Measurement trigger	internal	TRIG input SDI-12/RS485	TRIG input SDI-12/RS485
OP, measurement output	after measurement	just per command	after measurement

12.3.3.4 Output protocols

For data output via RS-485 different protocols are available, which can be selected under **Protocol type**.

12.3.4 Data output options

Data are returned in two different formats, selectable in **Protocol type**:



- Sommer Bus Protocol (SBP)
- Standard protocol

12.3.5 Sommer Bus Protocol (SBP)

The data string of the Sommer Bus Protocol has the following format:

```

✓ EXAMPLE #M0001G01se01    1461|02    1539|03    25.25|04
    0|ADC9;

```

A data string contains max. 8 values and is max. 105 characters long.

12.3.5.1 Header

The header (#M0001G01se) identifies the data by system key, device number and string number.

Parameter	Format	Description
Start character	#	
Identifier	M	M identifies an output string
System key	dd	
Device number	dd	
Command ID	G	G defines an output string with string number
String number	dd	01 Main values 03 Special values 05 Analysis values 06 Analysis values
Command	se	se identifies automatically sent values

Table 4 Header of the Sommer Bus Protocol

12.3.5.2 Measurement value

A measurement value (02 1539|) has a length of 8 digits and is returned together with its index. If the measurement value is a floating point number, one digit is reserved for the decimal character. Values are returned right-aligned, so blanks may occur between index and value.

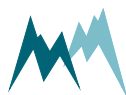

Parameter	Format	Description
Index	dd	2 numbers
Value	xxxxxxxx	8 character right-aligned
Separator		

Table 5 Values in Sommer Bus Protocol

12.3.5.3 End sequence

The data string is terminated with a CRC-16 in hex format (ADC9) followed by an end character and <CR><LF>. The CRC-16 is described in [Sommer Messtechnik CRC-16](#).

Parameter	Format	Description
CRC-16	hhhh	4-digit hex number
End character	;	
Control characters	<CR><LF>	Carriage return and Line feed

Table 6 End sequence of the Sommer Bus Protocol

12.3.5.4 Example Sommer Bus Protocol

12.3.5.4.1 Main values

Main values are returned as in the following example:

 **EXAMPLE** #M0001G01se01 24.7|02 1.21|03 23.44|04
23.00|0500000210|0801;

#M0001G01se	Header with system key 00, device number 01 and string number 01
01 24.7	Temp. medium
02 1.21	Density



03 23.44	Concentration
04 23.00	Set-point
00000210	Status
0801 ;	Closing sequence

Table 7 Main values in Sommer Bus Protocol

12.3.6 Standard protocol

The data string of the Standard protocol has the following format:

	EXAMPLE M_0001 1461 1539 25.25 0
---	---

12.3.6.1 Header

The header (M_0001) identifies the data by system key and device number.

Parameter	Format	Description
Identifier	X_	M_ Measurement values S_ Special values V_ Analysis values
System key	dd	
Device number	dd	

Table 8 Header of the Standard protocol

12.3.6.2 Measurement values

Measurement values are returned in sequence and are separated by a blank. A measurement value has a length of 8 digits. If the measurement value is a decimal number, one digit is reserved for the decimal character. Values are returned right-aligned, so additional blanks may be returned between values.



Parameter	Format	Description
Separator	[blank]	blank
Value	xxxxxxxx	8 character right-aligned

Table 9 Values in Standard protocol



NOTE With the standard protocol the data strings can be very long. In contrast, the strings of the Sommer Bus Protocol are max. 105 characters long.

12.3.6.3 End sequence

The data string is terminated with <CR><LF>.

12.3.6.4 Example Standard protocol

12.3.6.4.1 Main values

Main values are returned as in the following example:

	EXAMPLE M_0001 24.0 1.21 23.44 23.00 00000210
--	---

M_0001	Header with identifier for measurement values
24.7	Temp. medium
1.21	Density
23.44	Concentration
23.00	Set-point
00000210	Status

Table 10 Main values in Standard protocol



12.3.7 RS-485 commands

12.3.7.1 Command structure

The structure of serial commands and answers is described in the following table:

Parameter	Format	Description
Start character	#	
Identifier	X	<p>W Write: DP-20 returns a confirmation on receipt. This command type demands a closing sequence with a valid CRC-16.</p> <p>S Silent: DP-20 does not acknowledge the receipt of the command. This command type demands no closing sequence and therefore no CRC-16.</p> <p>R Read: DP-20 returns the requested measurement value or parameter. This command type demands a closing sequence with a valid CRC-16.</p> <p>T Temporary: Write a volatile, temporary setting and receive a confirmation.</p> <p>A Answer: Answer of device to read or write command.</p>
System key	dd	
Device number	dd	
Command	xxx	See table in section Commands .
Separator		
CRC-16	hhhh	4-digit hex number
End character	;	

Table 11 Structure of Sommer Bus Protocol commands and answers

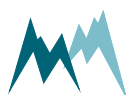

12.3.7.2 Commands

The following commands can be used with the DP-20:

Command	Description
\$mt	Trigger a measurement
\$pt	Return measurement values
XX	Read a parameter with identifier XX
XX=xxxx	Write a parameter with identifier XX and the value xxx

Table 12 List of Sommer Bus Protocol commands

12.3.7.3 Trigger a measurement

The command \$mt triggers a complete measurement sequence as in the following example:

 **EXAMPLE** #W0001\$mt|BE85; Answer: #A0001ok\$mt|4FA9;

12.3.7.4 Read a parameter value

Read measurement interval (in the example below the menu item B):

 **EXAMPLE** #R0001B|228B; Answer: #A0001B=300|F8B3;

12.3.7.5 Request a complete data string

The command \$pt requests a data string as in the following example:

 **EXAMPLE**
Option 1
 #W0001\$pt|7D19; Answer: #A0001ok\$pt|8C35;
Option 2



#S0001\$pt|

Answer: none

The data string is returned as soon as the DP-20 has processed the command. If a wrong command is entered, the device returns #A0001na\$pt|3D40;.

12.3.7.6 Request a single measurement value

The reading command R together with the index of the requested measurement returns a single measurement value. In the following example the measurement value with index 01 is requested:



EXAMPLE

Measurement Value cv:

#R0001_010cv|EA62; Answer: #A0001ok_010cv1461 |5D62;

Storage Value sv:

#R0001_010sv|F853; Answer: #A0001ok_010sv1461 |1D31;

12.3.8 Sommer Messtechnik CRC-16

The CRC-16 (cyclic redundancy check) used in data transmission of Sommer Messtechnik devices is based on the ZMODEM protocol. When data are exchanged between two devices the receiving device calculates the CRC-value. This value is compared to the CRC value sent by the other device to check if the data were transmitted correctly. Please refer to technical literature or contact Sommer Messtechnik for calculation of CRC-16 values.

You can [here](#) calculate the CRC of a command online .

If you need to compute CRCs automatically, you can implement the following procedure in your data logger or controller software.

The CRC-16 is calculated character by character. The start value for the initial CRC-16 calculation is always 0.

The following procedure returns the CRC-16 of a single character:

byte1 = CRC-16 right shift by 8 bits	upper byte disappears
uint1 = c	new character, upper byte = 0
uint2 = CRC-16 left shift by 8 bits	lower byte = 0
uint3 = crc16tab[byte1]	Table value from the CRC-16 table
Crc16 = uint3 (excl. or) uint2 (excl. or) uint1	

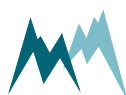

Computation CRC-16 in C/C++

```
1 | crc16 = crc16tab[(unsigned char)(crc16>>8)] ^ (crc16<<8) ^ (unsigned int)(c);
```

The `crc16tab` array is listed in [CRC-16 array](#).

**EXAMPLE**

Command to request measurement data `#W0001$pt|7D19;`

The first character is `#`, the last `|`. The CRC-16 of the command is `7D19` and its end character is `;`.

The CRC-16 is calculated sequentially with the start value `0` for the initial CRC-16 calculation:

Position	String	CRC-16
Start		0000
0	#	0023
1	#W	2357
2	#W0	4331
3	#W00	4997
4	#W000	4EDD
5	#W0001	743B
6	#W0001\$	0537
7	#W0001\$p	67D5
8	#W0001\$pt	C935
9	#W0001\$pt	7D19

12.4 SDI-12

12.4.1 What is SDI-12?

SDI-12 (Serial Data Interface at 1200 Baud) is a serial data communication standard for interfacing multiple sensors with a single data recorder. For a detailed description on SDI-12 communication please refer to www.sdi-12.org.

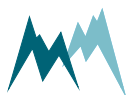

12.4.2 What can I do with it?

The DP-20 listens to standard SDI-12 commands as listed in the SDI-12 specifications of version 1.3, e.g., to trigger a measurement or retrieve measurement results. Additionally, a set of extended SDI-12 commands is implemented in all SOMMER sensors for instrument configuration.

12.4.3 Configuration

The DP-20 has SDI-12 communication enabled by default. When setting up a SDI-12 network take the following considerations into account:

- Each device in the SDI-12 network must have a unique address, e.g. data logger address *0*, DP-20 address *1*.
- The DP-20 operates in pushing mode and data are retrieved by **R!** commands.
- When multiple sensors are connected to the same network, data acquisition should be done in sequence, i.e., data should have been received from the first sensor before triggering the measurement of the second sensor.
- Most data loggers control the timing of messages (marking and spacing) automatically. If this is not the case, please refer to www.sdi-12.org.

12.4.4 Data structure

The answer from the SDI-12 device is a string containing the sensor address, the requested data and a terminating carriage return/line feed.

In a string containing measurement data, the measurements are returned in the same order as listed by the index in [Data output](#).



EXAMPLE

```
0+2591+706+25.53+62<CR><LF>
```

Value	Content
0	Sensor address
2591	Measurement with index 01
706	Measurement with index 02
25.53	Measurement with index 03
62	Measurement with index 04

If a device returns more than 9 measurement values, or if the values are returned in groups (see also [Request results](#)) the measurement index increments in the next group.

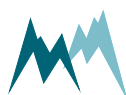

**EXAMPLE**

0D0! Answer: 0+2591+706+25.53+62<CR><LF>

0D0! Answer: 0+56.2+125+12.32<CR><LF>

Value	Content
0	Sensor address
2591	Measurement with index 01
706	Measurement with index 02
25.53	Measurement with index 03
62	Measurement with index 04
0	Sensor address
56.2	Measurement with index 05
125	Measurement with index 06
12.32	Measurement with index 07

12.4.5 SDI-12 commands

The following tasks can be performed with standard and extended SDI-12 commands.

Extended SDI-12 commands are non-standard commands implemented by SOMMER to enable device configuration via SDI-12.



NOTE After any changes, the settings have to be adopted with the command `aXW_ts|!`, with `a` the sensor address.

12.4.5.1 Command structure

A standard SDI-12 command starts with the sensor address and ends with an exclamation mark, e.g., `0M!` to trigger a measurement.

Configuration commands contain additional information; see the sections below for details.

12.4.5.2 Identify device

The identification of a SDI-12 device is requested with the command `aI!`, with `a` the sensor address.

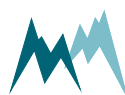

**EXAMPLE**

0I! Answer 013Sommer USH 140r90 USH-9 <CR><LF>

The answer contains the following information:

0	SDI-12 address
1	SDI-12 version prior to the point
3	SDI-12 version after the point
Sommer	Description of the company (6 characters and 2 blanks)
USH	Description of the firmware (5 characters and 2 blanks)
140r90	Firmware version (6 characters and 2 blanks)
DP-20	Device designation (max. 13 characters)

12.4.5.3 Acquire measurements

To acquire a measurement from a sensor, two individual SDI-12 commands – trigger a measurement and request measurement values – need to be sent.

**EXAMPLE**

0M! Answer: 00084<CR><LF> and 0<CR><LF> after 8 seconds

0D0! Answer: 0+2591+706+25.53+0<CR><LF>

The first values in the response to the aDn! command is the sensor address.

12.4.5.4 Trigger measurement

The command aM! with sensor address a triggers a measurement as in the example below.

The response states the measurement duration and the number of measurement values (see example below). After completion of the measurement, the device will return an additional a<CR><LF>, with a the sensor address.

**EXAMPLE**

0M! Answer: 00084<CR><LF> and 0<CR><LF> after 8 seconds

The answer contains the following information:





0	SDI-12 address
008	Duration of the measurement in seconds
4	Number of measurement values

12.4.5.5 Request results

After each measurement, results are requested with the command `aDn!`, with `a` the sensor address and `n` the index of the returned data string.



EXAMPLE `0D0!` Answer: `0+2591+706+25.53+0<CR><LF>`

The leading `0` of the response is the sensor address.

Generally, the command `aD0!` is sufficient to request up to 9 measurement values. If more than 9 values need to be read, or if the values are returned in groups, the commands `aD1!`, `aD2!`, ... may need to be issued after `aD0!`. For example, if a measurement returns 8 values in two groups of 4, the commands `aD0!` and `aD1!` need to be issued to receive all values.

12.4.5.6 Acquire continuous measurements

If the SDI-12 device is operating in continuous measurement mode (not polled by SDI-12), the command `aR0!` will request and return the current reading of the sensor. The values within the data string follow the order listed in the measurement table. The first values in the response to the `aRn!` command is the sensor address.



EXAMPLE
`0R0!` Answer: `0+2591+706+25.53+0<CR><LF>`



ATTENTION

If more than 8 values need to be read, or if the values are returned in groups, the commands `aR1!`, `aR2!`, ... may need to be issued after `aR0!`. For example, if a measurement returns 8 values in two groups of 4, the commands `aR0!` and `aR1!` need to be issued to receive all values.

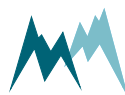

12.4.5.7 Configure parameter

The configuration parameters of a SOMMER sensor are read with the command `aXRpp!` and written with the command `aXWpp=vvv!`, with `a` the sensor address, `pp` the parameter identifier and `vvv` the value of the parameter.

12.4.5.8 Read and write a parameter



EXAMPLE

Reading of measurement interval (in this example menu item B)

`0XRB|!` Answer: `0B=300|<CR><LF>`

Setting of measurement interval to 60 s (in this example menu item B)

`0XWB=60|!` Answer: `0B=60|<CR><LF>`

12.4.5.9 Read and write a selector-parameter

Changing the measurement trigger (in the following example menu item A) from *interval* to *SDI-12/RS485*:



EXAMPLE

`0XRA|!` Answer: `0A=1|<CR><LF>`

`0XWA=3|!` Answer: `0A=3|<CR><LF>`

12.4.5.10 Read and write a parameters of a table

Some SOMMER sensors are equipped with multiple transducers and their settings are listed in a table (see example below). A value within such a table is addressed by its row-index (01, 02, ...) and column-index (A, B, ...). A corresponding SDI-command has the following format:



EXAMPLE

In this example of a snow scale the value in row 01 and column B of the parameter D-D-E is changed to -1.4.

`0XWDDE01B=-1.4|!` Answer: `0DDE01b=-1.4|<CR><LF>`



	Identifier	offset zero kg	gain	zero default kg	gain default
01	Load Cell 1	-1.4	0,997787	0,000	0,997787
02	Load Cell 2	0,000	0,997787	0,000	0,997787
03	Load Cell 3	0,000	0,997787	0,000	0,997787
04	Load Cell 4	0,000	0,997787	0,000	0,997787

12.4.5.11 Adopt settings

Some settings need to be adopted with the command `aXW_ts|!`, with `a` the sensor address. It is recommended to issue `aXW_ts|!` after each configuration change.

12.5 Modbus

12.5.1 What is Modbus?

Modbus is a serial communication protocol used for transmitting information over serial lines between electronic devices. The device requesting the information is called the Modbus Master and the devices supplying information are Modbus Slaves. In a standard Modbus network, there is one Master and up to 247 Slaves, each with a unique Slave Address from 1 to 247. The Master can also write information to Slaves.

Modbus has become a standard communication protocol in industry, and is now the most commonly available means of connecting industrial electronic devices. It is often used to connect a supervisory computer with a remote terminal unit (RTU) in supervisory control and data acquisition (SCADA) systems. Versions of the Modbus protocol exist for serial lines (Modbus RTU and Modbus ASCII) and for Ethernet (Modbus TCP).¹

12.5.2 What can I do with it?

Modbus-communication with DP-20 allows reading of measurement values and device information by a Modbus master. Additionally, the basic RS-485 port settings can be written to the DP-20.

¹<http://www.simplymodbus.ca/FAQ.htm>



12.5.3 Wiring

For Modbus communication the DP-20 is wired according to the table below.

Modbus	Connector MAIN	Connection wire	Description
Common	Pin 1	White	GND
D1 - B/B	Pin 4	Yellow	RS-485 A
D0 - A/A	Pin 5	Grey	RS-485 B

Table 13 Modbus wiring



NOTE

Please note that different signal notations are in use for RS-485 connections:

TX+/RX+ or D+ or D1 as alternative for B

TX-/RX- or D- or D0 as alternative for A



NOTE If the DP-20 is operated with multiple Modbus devices within the same network, termination resistors may be required. Please contact Sommer Messtechnik for details.

12.5.4 Modbus configuration

Follow the instructions below to change the communication of a Sommer Messtechnik device (in this example a RG-30) to Modbus:

1. Connect the USB to RS-485 converter to the data cable of the Sommer Messtechnik device and a USB port on your PC.
2. Connect the sensor to a power supply with the specified rating.
3. Start the Commander software on your PC.
4. Establish a connection to the Sommer Messtechnik device.
5. Download the sensor's parameters in the **Parameters (F2)** tab and save the parameter list on your PC.

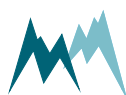



6. In the parameter list navigate to Technics and open the menu **RS485 (COM)** and take a screenshot of the associated parameters. This and the previous step are helpful if you need to switch back to the standard communication mode at a later time.

Parameters			
Main menu			
A	Measurement trigger	Interval	▼
B	Measurement interval	60	sec
▶	C DIG-OUT limit monitor		
▲	D Technics		
▶	A Units Expand		
▲	B SBP device addressing		
A	Device number	01	
B	System key	00	Expand
▲	C RS485 (COM)		
▲	A Output protocol		
A	Output protocol	Sommer	▼
B	Measurement output	After measurement	▼
C	Information	& Special values	▼
D	Wake-up sequence	Prefix	▼
E	Prefix holdback	300	ms
F	MODBUS, set default		
G	MODBUS, device address	35	Expand
▲	B Port		
A	Baudrate	9600	▼
B	Parity, stop bits	No par, 1 stop	▼
C	Minimum response time	10	ms
D	Transmitter warm-up time	10	ms
E	Flow control	Off	▼
F	Sending window	300	ms
G	Receiving window	300	ms
▶	D SDI12 Slave		
▶	E Additional settings		

7. Set **Measurement trigger** to one of the following options:
- Interval*, if measurements are triggered internally by the device.
 - SDI-12/RS-485*, if measurements are triggered by SDI-12.
 - TRIG input*, if measurements are triggered by a trigger input.
 - all allowed*, if measurements are triggered by one of the previous options.





NOTE Modbus cannot trigger measurements! Make sure to use the trigger option suitable for your application!

- Verify that the connection to the Sommer Messtechnik device is active and click into the Terminal window. Type ??? to enter the sensor-menu.

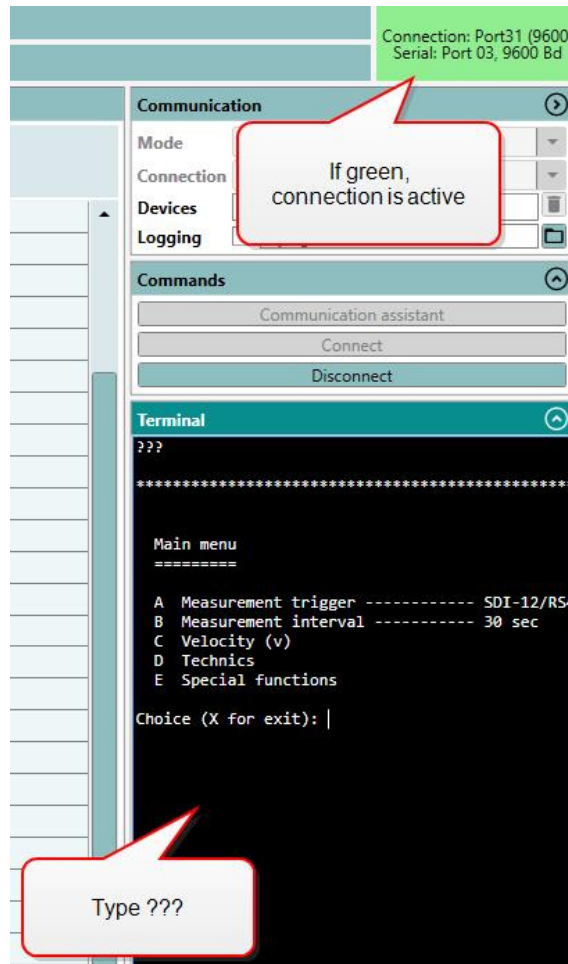

- Navigate to *RS485 protocol* and select *MODBUS, set default...* Please note, that the index-letters might be different for your Sommer Messtechnik device!

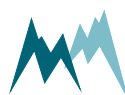

```

Terminal

Main menu
=====

A Measurement trigger ----- SDI-12/RS485
B Measurement interval ----- 30 sec
C Velocity (v)
D Technics
E Special functions

Choice (X for exit): d

Technics
=====

A Language/Sprache ----- english/englisch
B Decimal character ----- dot
C SDI-12 address ----- 1
D Channel type ----- open
E Advanced settings
F Tech. velocity (v)
G RS485 protocol
H RS485
I Units and decimals

Choice (X for exit): g

RS485 protocol
=====

A Device number
B System key --
C Output protocol
D Output (MO) t
E MO information
F MO wake-up se
G MO prefix holdback ----- 100 ms
H MODBUS, set default...
I MODBUS, device address ----- 35

Choice (X for exit): |

```

Enter the letter of 'MODBUS, set default...'

10. Acknowledge the safety-note.

```

Start up testmode: 0x09

MODBUS, set default
AAAAAAAAAAAAAAAAAAAA

PLEASE NOTE: This process changes to 19200 baud, even parity, ...
DIRECTIVE: Please don't forget to change the serial counterpart too!

Are you sure?

(Press "RETURN" to assume)
(Press "Esc" to cancel)

```

Press Enter

11. After completion the following message will be displayed:

```

=> Testmode finished!
=> DIRECTIVE: Please don't forget to change the serial counterpart too!

```

12. Enter X until you get back to the main menu. The Sommer Messtechnik device is now restarted and available for Modbus-communication. As the connection-parameters have been changed to Modbus, the connection to the sensor is lost. Press Disconnect for completion.

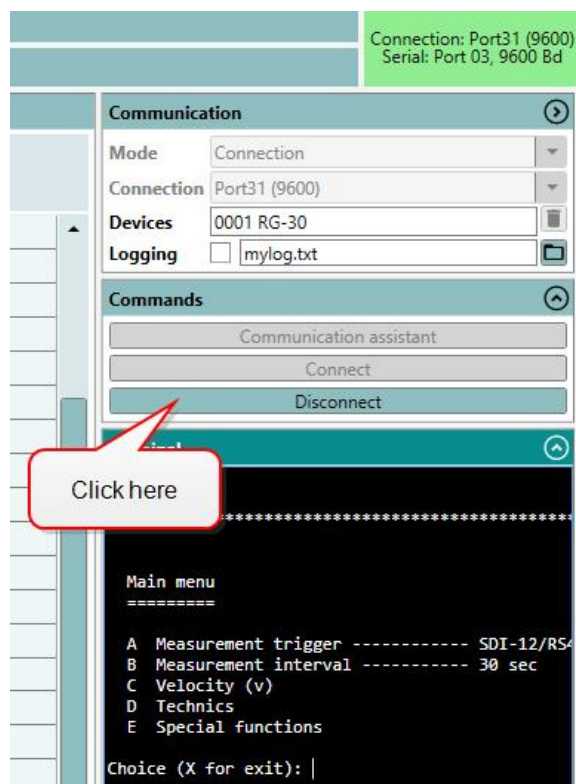

NOTE

By switching communication to Modbus with **MODBUS**, set default the following parameters are changed:

Parameter	Modbus setting
OP, measurement output	just per command
Output protocol (OP)	Modbus
MODBUS, device address	35
Sleep mode	Modbus, slow
Parity, stop bits	even par, 1 stop
Baud rate	19200
Flow control	off
Transmitter warm-up time	10 ms
Minimum response time	30 ms



TIP To change a parameter in the **Technics** menu you need to change your Commander-authorization to Expert. See [Change authorization](#) for instructions.

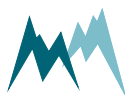

12.5.5 Modbus commands and registers

12.5.5.1 Read input registers

Input registers contain measurement values. The content of these registers is updated after each measurement.

Index	Register address	Variable	Unit / value	Bytes	Format
Test value	0	Hardcoded test value	2.7519...	4	float
Main values					
01	2	Temp. medium	°C	4	float
02	4	Density	g/cm ³		
03	6	Concentration	%		
04	8	Set-point	%		
05	10	Status	-		
Device info					
-	65533	Device type and configuration	3701	2	unsigned int
-	65534	Software version	XYZZ	2	
-	65535	Modbus version	10100	2	

Table 14 Input registers



NOTE

The 4-byte float values have the format *ABCD*, big-endian (*A* is the most significant byte).

Note the difference between float, double and decimal data types. While float is a 4-byte floating-point-number, double is a 8-byte and decimal a 16-byte floating-point number. Use the applicable conversion to obtain the correct measurement values!

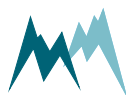

12.5.5.2 Read and write holding registers

Holding registers are mainly used to configure the Modbus adapter communication. Configuration settings are read with function 03 (read holding registers) and written with function 06 (write single registers).



NOTE Restart the Modbus adapter after changing the configuration!

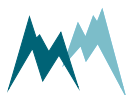

	Register address	Variable	Range	Bytes	Format
Config values	0	Modbus default	0 ... read 1 ... write	2	unsigned int
	1	Modbus device address	1 to 247		
	2	RS-485 baud rate	1 ... 1200 baud 2 ... 2400 baud 3 ... 4800 baud 4 ... 9600 baud 5 ... 19200 baud 6 ... 38400 baud 7 ... 57600 baud 8 ... 115200 baud		
	3	RS-485 parity/ stop bits	1 ... no parity, 1 stop bit 2 ... no parity, 2 stop bits 3 ... even parity, 1 stop bit 4 ... odd parity, 1 stop bit		
	101	Select medium	1 ... no medium 2 ... NaCl 3 ... CaCl ₂ 4 ... MgCl ₂ 5 ... custom medium 6 ... external input		
	102	Activate mixing	1 ... on 2 ... off		
	103	Set-point NaCl conc. [%]	x.x		
	104	Set-point CaCl ₂ conc. [%]	x.x		
	105	Set-point MgCl ₂ conc. [%]	x.x		
	106	Set-point custom medium conc. [%]	x.x		

Table 15 Holding registers

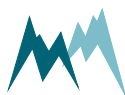

12.5.5.3 Report slave ID

The Modbus function 17 (report slave ID, read only) can be used to read basic information of the DP-20. The following example shows the response of function 17 of a RG-30 sensor, which is received in hex-format:



EXAMPLE 23 11 26 53 FF 27 74 20 53 6F 6D 6D 65 72 20
20 52 47 2D 33 30 20 20 20 32 5F 37 31 72 30 31 20 34
35 31 35 31 38 32 31 00 BB D4

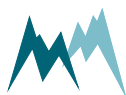

			Example	
	Content	Length (Bytes)	HEX-value	Decimal, ASCII
PDU* response	Slave address	1	23	35
	Function code	1	11	17
	Number of bytes (excl. slave-address, function code, NUL and CRC)	1	26	38
	Slave ID	1	53	"S"
	Run status (0=inactive; FF=active)	1	FF	255
	Modbus implementation version	2	27 74	10100
	Separator	1	20	" "
	Vendor string	7	53 6F 6D 6D 65 72 20	"Sommer "
	Separator	1	20	" "
	Device configuration	7	52 47 2D 33 30 20 20	"RG-30 "
	Separator	1	20	" "
	Software version	7	32 5F 37 31 72 30 31	2_71r01
	Separator	1	20	" "
	Serial number	8	34 35 31 35 31 38 32 31	45151821
	NUL	1	00	
	CRC	2	BB D4	

*Protocol Data Unit

Table 16 Slave ID

12.5.6 Reactivate Sommer Bus Protocol

Follow the instructions below to change the data output back to Sommer Bus Protocol:

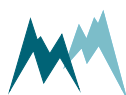

1. Open the **Connections (F8)** tab and click **New connection**.

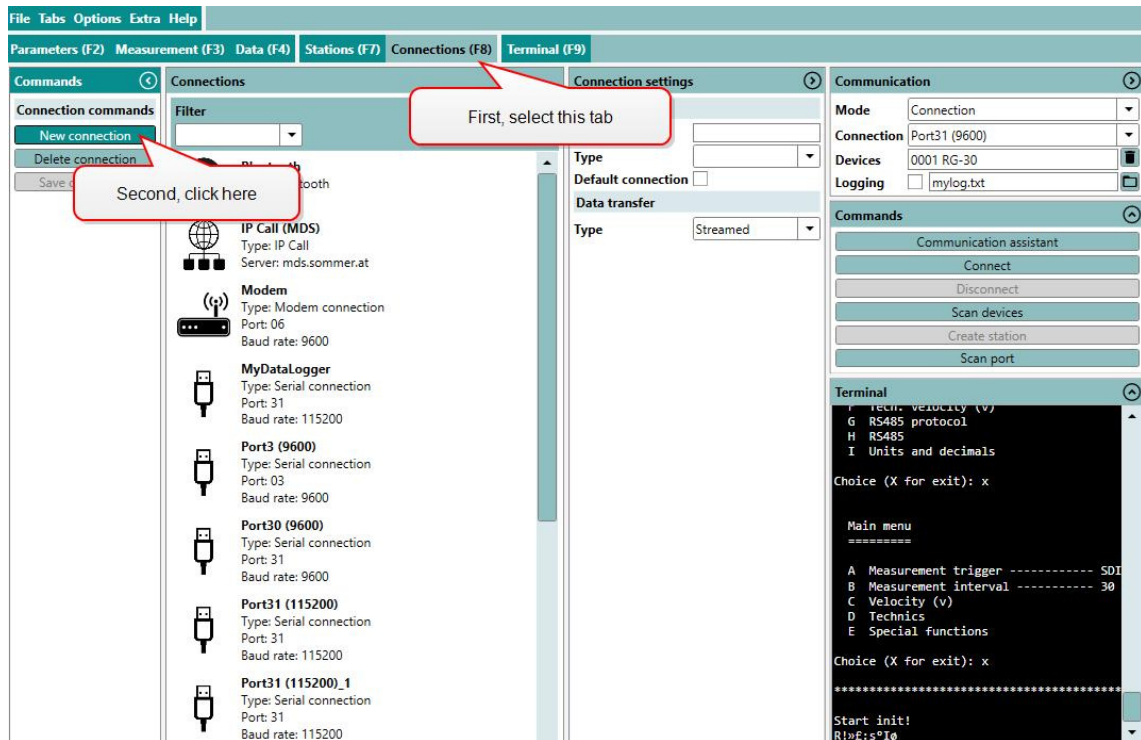

2. Enter the **Name** of the new connection. We recommend to use a meaningful name for later recognition, e.g. Modbus31 (19200) to indicate port 31 and Baud-rate 19200. Select the **Type** **Serial connection** and choose the **Port** your sensor is connected to, set the **Baud-rate** to **19200** and the **Parity/stop bits** to **Even par., 1 stop bit**.

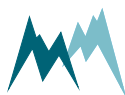

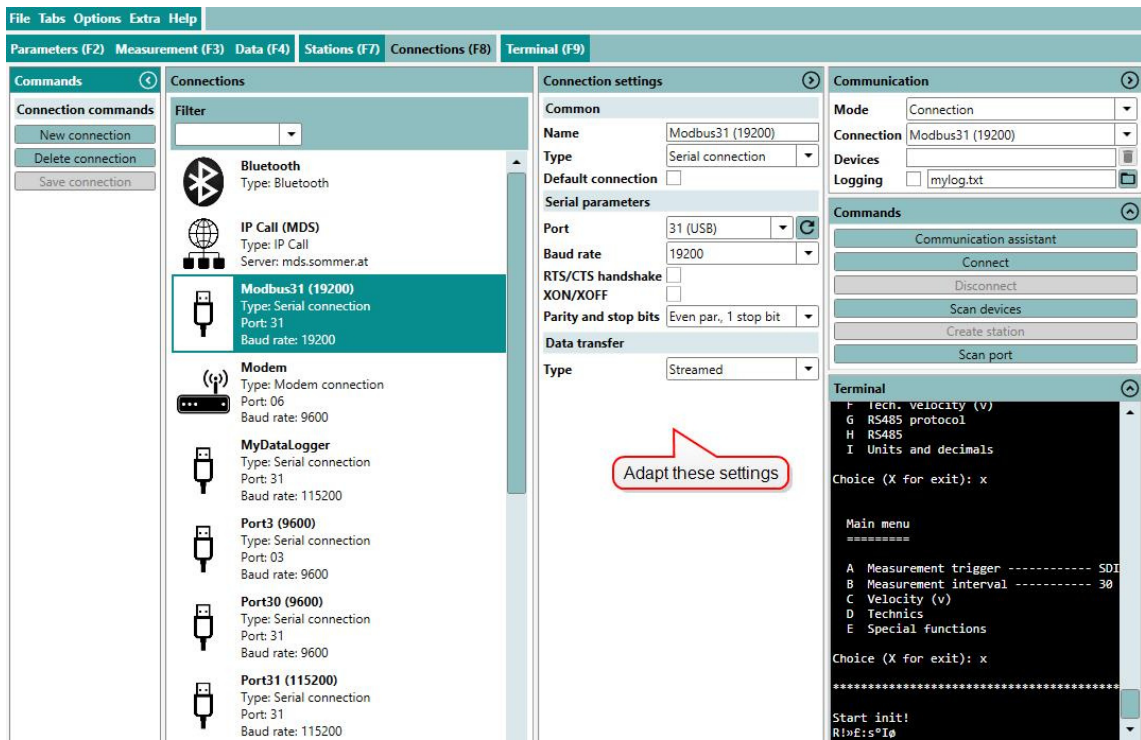

3. Click **Save connection**.
4. In the **Communication** window select **Mode Connection** and choose the **Connection** you have created. Then click **Connect**.

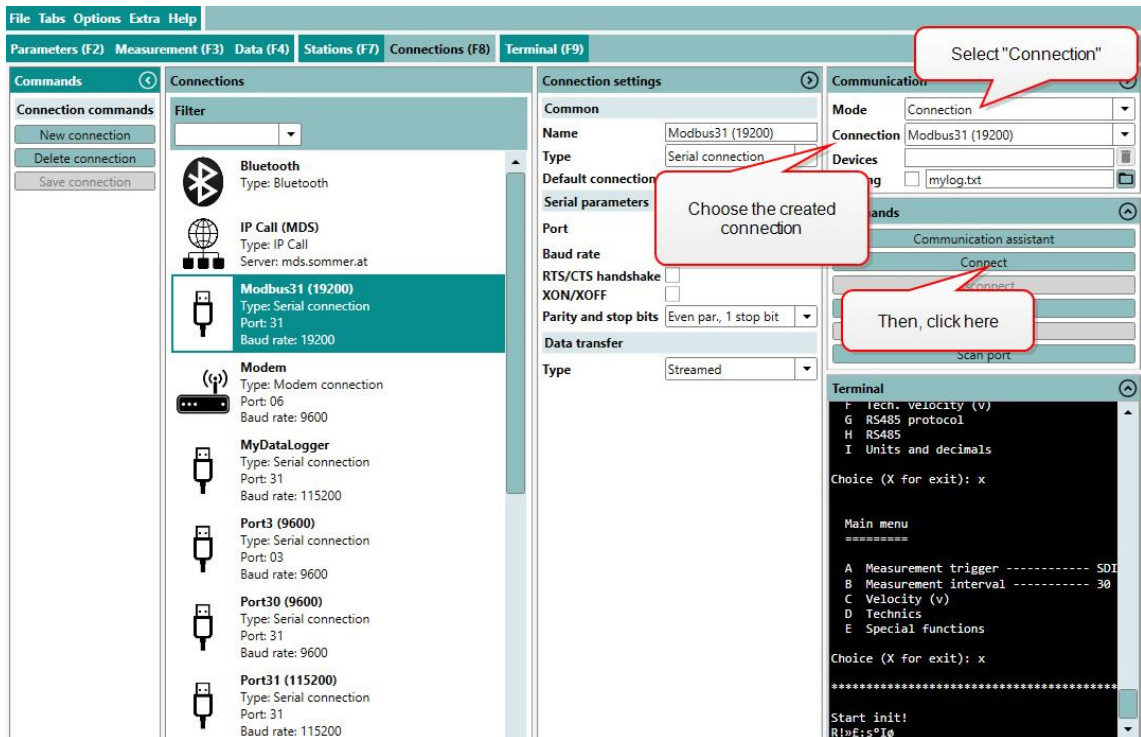

5. Download the parameters and save the parameter file as described in **Modbus configuration**.

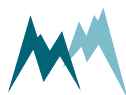



TIP Save the parameter file for future use and to document configuration changes!

6. Now, two options are available to revert communication back to the Sommer Bus Protocol:
 - A. If a parameter file is available that has the Sommer Bus Protocol enabled, the file can be loaded by clicking **Open parameter file**, selecting the respective file and uploading the parameters to the device by clicking **Upload all parameters to device**.

The screenshot shows the software interface with the 'Parameters' tab selected. The 'File commands' section is highlighted, and two red callout boxes point to the 'Open parameter file' and 'Upload all parameters to device' buttons. The 'Terminal' window shows a list of hex addresses and their corresponding German and English messages.

```
0x0400 "ACHTUNG: Evtl. schwierige Interpretation"
0x0800 "PLEASE NOTE: Maybe difficult interpretation"
0x0800 "Vorgang ist derzeit belegt, bitte warten"
0x1000 "Action currently not available, please wait"
0x1000 "ANWEISUNG: Bitte nicht vergessen, die Messung zu starten"
0x2000 "DIRECTIVE: Please don't forget to start the measurement"
0x2000 "ACHTUNG: Ein alter Archiv-Zeiger wird verwendet"
0x4000 "PLEASE NOTE: An old archive pointer is used"
0x4000 "ACHTUNG: Bitte 'W-v Tabelle Neustart' verwenden"
0x8000 "PLEASE NOTE: Please perform a 'W-v Table Restart'"
0x8000 ""
#A0001 c:0x4944|8D37;
#A0001 V:2_63r01 N:45151821 E:0x0000 P:1 t:R;
#A0001 e i:00000000|C856;
#A0001 a=3|B=30|CA=2|CB=1|A261;
#A0001 c=0|CD=0|CE=20|CF=1|50C1;
#A0001 G=4|DA=2|DB=2|DC=1|8EDD;
#A0001 DD=1|DEA=1|DEB=5|DEC=2|83B9;
#A0001 DED=0|DFA=1|DFB=5|DFC=2|02D8;
#A0001 DFD=1|DFE=20|DFG=50|DFH=3|0837;
#A0001 DFH=2|DFI=100|DFJ=-1|DGA=1|1A82;
#A0001 DGB=0|DGC=1|DGD=1|DGE=3|AD5E;
#A0001 DGF=3|DGG=300|DGI=35|DHA=4|9EB1;
#A0001 DHB=1|DHC=0|DHD=10|DHE=1|5AES;
#A0001 DHF=300|DHG=300|DIA=2|DIB=2|1074;
```

- B. If no parameter file is available, the device has to be reset to its default configuration:

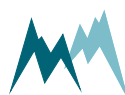

1. Click into the **Terminal** window and type `???` to enter the sensor-menu.

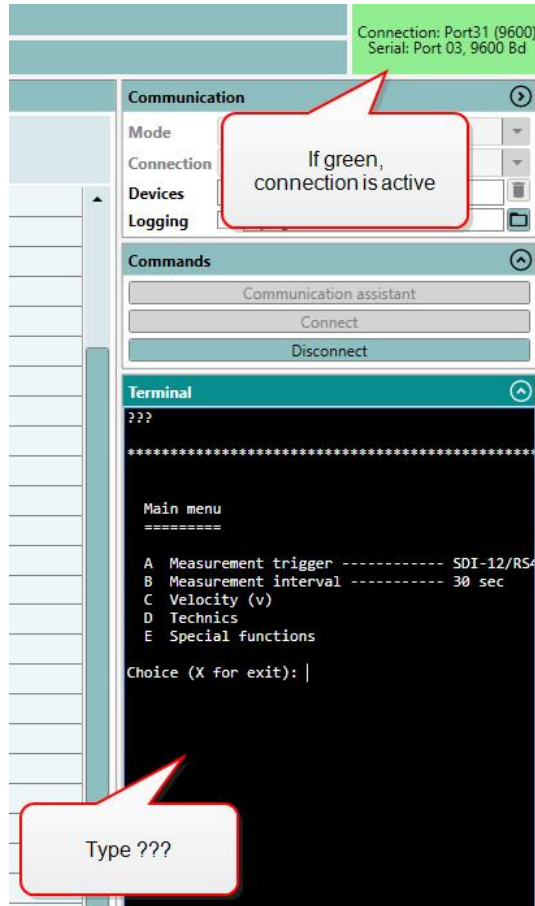

2. Navigate to **Special functions** and select **Set factory default...**
3. Acknowledge the safety-note.

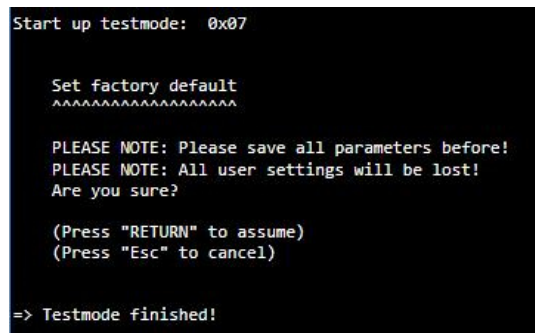

4. Enter `X` until you get back to the main menu. The Sommer Messtechnik Sensor is now restarted and available in its initial configuration. As the connection-parameters have been changed to the default settings, the connection to the sensor is lost. Press **Disconnect** for completion.
7. Establish the original connection to the Sommer Messtechnik Sensor as described in **Modbus configuration**.

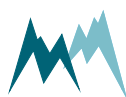

8. Download the sensor's parameters in the [Parameters \(F2\)](#) tab, adapt the required parameters, or upload your originally saved parameter file to the DP-20.

12.5.7 PLC integration

The DP-20 can be integrated into a PLC system as a slave device. It supports the PROFIBUS, PROFINET, EtherCAT and CANopen protocols. This requires an additional serial converter, e.g. Anybus Communicator.

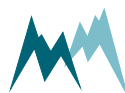

13 Analog output

13.1 What can I do with it?

The DP-20 provides two analog outputs, one for solute concentration or medium density and one for medium temperature.

13.2 Scaling

The variables and their analog output ranges are configured as described below.



NOTE

The analog outputs may return currents between 0 and 21 mA. However, the accuracies stated in the specifications are only valid for signals within 4 to 20 mA!

If the measured value falls below or exceeds the 3.9...21 mA range, 3.9 mA and 21 mA, respectively, are returned. An exception are the measurement values 99999998 and 99999997, which return a 3.8- mA and 3.7- mA signal, respectively.

13.3 IOUT 1

The analog output IOUT1 returns the solute concentration or medium density and can be selected in [IOUT1, output parameter](#). For this output the following signal types can be selected:

ID	Option	Description
1	4-20 mA	Current output 4 ... 20 mA
2	0-20 mA	Current output 0 ... 20 mA
3	0-10 V	Voltage output 0 ... 10 VDC

13.3.1 Density output

Minimum and span values for the density output can be set in [IOUT1, density min. value](#) and [IOUT1, density span](#).

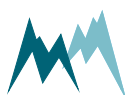



EXAMPLE

In the default configuration the parameter **IOUT1**, Output option is set to **4-20mA**, **IOUT1**, density span to **0.400** and **IOUT1**, density min. value to **1000 g/cm³**, as illustrated below.

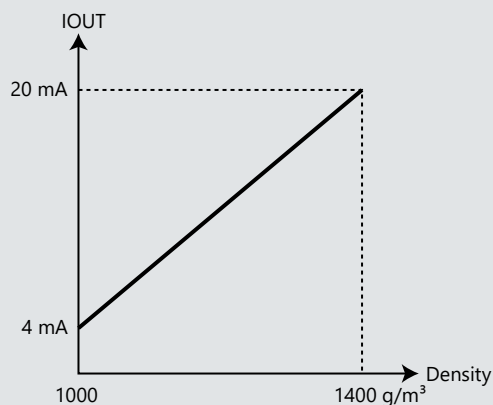

13.3.2 Concentration output

Minimum and span values for the solute concentration output can be defined in the settings of the selected medium, i.e. [NaCl settings](#), [CaCl₂ settings](#) and [MgCl₂ settings](#).



EXAMPLE

In the default configuration the parameter **IOUT1**, Output option is set to **4-20mA**, **IOUT1**, concentration span to **10** and **IOUT1**, concentration min. value to **15 %**, as illustrated below.

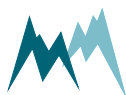
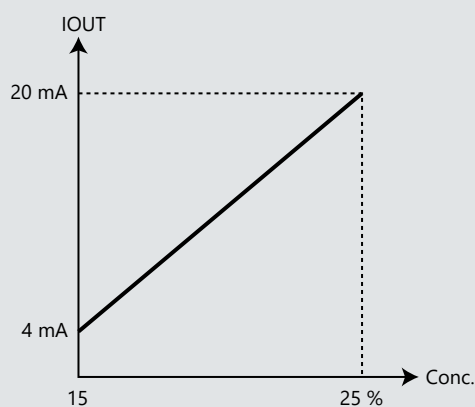

13.4 IOOUT 2

The analog output IOOUT2 returns the medium temperature as a 4-20 mA signal. By default the 4-mA current corresponds to -20°C and the span to 100°C. Minimum value and span can be configured in [IOOUT settings](#).

13.5 Simulate current output

With this function the analog outputs can be simulated. A user-defined current value between 4 and 20 mA is applied to the analog output pins, which can be read by a connected data acquisition device or multimeter. By pressing Return/Enter again the simulation stops.

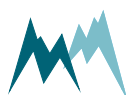

14 Parameter definitions

A	Medium	98
B	Medium settings	98
C	Technics	108
D	Special functions	125
E	Measurement table	126

A Medium

dp-medium

The medium of which the density and concentration are determined by the DP-20. The following options are available:

ID	Option	Description
1	no medium	No medium is selected and the DP-20 only measures density.
2	NaCl	Solute NaCl is active and its concentration [% m/v] is returned.
3	CaCl ₂	Solute CaCl ₂ is active and its concentration [% m/v] is returned.
4	MgCl ₂	Solute MgCl ₂ is active and its concentration [% m/v] is returned.
5	custom medium	A custom solute is active and its concentration [% m/v] is returned.
6	external input	One of the media NaCl, CaCl ₂ and MgCl ₂ is selected by an external switch and the DP-20 digital inputs IN2, IN3, IN4.

B Medium settings

B-A	NaCl settings	98
B-B	CaCl ₂ settings	100
B-C	MgCl ₂ settings	102
B-D	Custom medium settings	104

B-A NaCl settings

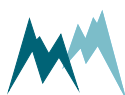

B-A-A Set-point

dp-set-point

The target concentration of the solute.

Value range	Default	Units
0 ... 99.9	NaCl ... 22.0 CaCl ₂ ... 26.0 MgCl ₂ ... 26.0 Custom ... 0.0	% m/v

B-A-B Minimum set-point

dp-minimum-set-point

The minimum solute concentration to which the set point can be adjusted. If the concentration set point entered over the LC-Display MD-10 is lower, it is set to this value.

Value range	Default	Units
0 ... 99.9	NaCl ... 15.0 CaCl ₂ ... 12.5 MgCl ₂ ... 12.5 Custom ... 0.0	% m/v

B-A-C Maximum set-point

dp-maximum-set-point

The maximum solute concentration to which the set point can be adjusted. If the concentration set point entered over the LC-Display MD-10 is higher, it is set to this value.

Value range	Default	Units
0 ... 99.9	NaCl ... 25.0 CaCl ₂ ... 37.5 MgCl ₂ ... 37.5 Custom ... 99.9	% m/v

B-A-D IOUT1 concentration span

dp-analog-out-iout1-concentration-span

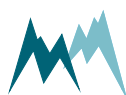

The span of the solute concentration that corresponds to the 4 ... 20 mA output of the analog IOOUT1.

Value range	Default	Units
0 ... 100	NaCl ... 10.0 CaCl ₂ ... 25.0 MgCl ₂ ... 25.0 Custom ... 99.9	% m/v

B-A-E IOOUT1 concentration min. value

`dp-analog-out-iout1-concentration-min-value`

The solute concentration that corresponds to the 4 mA output of the analog IOOUT1.

Value range	Default	Units
0 ... 99.9	NaCl ... 15.0 CaCl ₂ ... 12.5 MgCl ₂ ... 12.5 Custom ... 0.0	% m/v

B-A-F Set-point range +/-

`dp-set-point-range`

The acceptable tolerance of the solute concentration set-point.

Value range	Default	Units
0 ... 99.9	1.0	% m/v

B-B CaCl₂ settings

B-B-A Set-point

`dp-set-point`

The target concentration of the solute.



Value range	Default	Units
0 ... 99.9	NaCl ... 22.0 CaCl ₂ ... 26.0 MgCl ₂ ... 26.0 Custom ... 0.0	% m/v

B-B-B Minimum set-point

dp-minimum-set-point

The minimum solute concentration to which the set point can be adjusted. If the concentration set point entered over the LC-Display MD-10 is lower, it is set to this value.

Value range	Default	Units
0 ... 99.9	NaCl ... 15.0 CaCl ₂ ... 12.5 MgCl ₂ ... 12.5 Custom ... 0.0	% m/v

B-B-C Maximum set-point

dp-maximum-set-point

The maximum solute concentration to which the set point can be adjusted. If the concentration set point entered over the LC-Display MD-10 is higher, it is set to this value.

Value range	Default	Units
0 ... 99.9	NaCl ... 25.0 CaCl ₂ ... 37.5 MgCl ₂ ... 37.5 Custom ... 99.9	% m/v

B-B-D IOU1 concentration span

dp-analog-out-iout1-concentration-span

The span of the solute concentration that corresponds to the 4 ... 20 mA output of the analog IOU1.

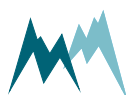

Value range	Default	Units
0 ... 100	NaCl ... 10.0 CaCl ₂ ... 25.0 MgCl ₂ ... 25.0 Custom ... 99.9	% m/v

B-B-E IOUT1 concentration min. value

dp-analog-out-iout1-concentration-min-value

The solute concentration that corresponds to the 4 mA output of the analog IOUT1.

Value range	Default	Units
0 ... 99.9	NaCl ... 15.0 CaCl ₂ ... 12.5 MgCl ₂ ... 12.5 Custom ... 0.0	% m/v

B-B-F Set-point range +/-

dp-set-point-range

The acceptable tolerance of the solute concentration set-point.

Value range	Default	Units
0 ... 99.9	1.0	% m/v

B-C MgCl₂ settings

B-C-A Set-point

dp-set-point

The target concentration of the solute.



Value range	Default	Units
0 ... 99.9	NaCl ... 22.0 CaCl ₂ ... 26.0 MgCl ₂ ... 26.0 Custom ... 0.0	% m/v

B-C-B Minimum set-point

dp-minimum-set-point

The minimum solute concentration to which the set point can be adjusted. If the concentration set point entered over the LC-Display MD-10 is lower, it is set to this value.

Value range	Default	Units
0 ... 99.9	NaCl ... 15.0 CaCl ₂ ... 12.5 MgCl ₂ ... 12.5 Custom ... 0.0	% m/v

B-C-C Maximum set-point

dp-maximum-set-point

The maximum solute concentration to which the set point can be adjusted. If the concentration set point entered over the LC-Display MD-10 is higher, it is set to this value.

Value range	Default	Units
0 ... 99.9	NaCl ... 25.0 CaCl ₂ ... 37.5 MgCl ₂ ... 37.5 Custom ... 99.9	% m/v

B-C-D IOU1 concentration span

dp-analog-out-iout1-concentration-span

The span of the solute concentration that corresponds to the 4 ... 20 mA output of the analog IOU1.

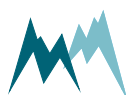

Value range	Default	Units
0 ... 100	NaCl ... 10.0 CaCl ₂ ... 25.0 MgCl ₂ ... 25.0 Custom ... 99.9	% m/v

B-C-E IOUT1 concentration min. value

dp-analog-out-iout1-concentration-min-value

The solute concentration that corresponds to the 4 mA output of the analog IOUT1.

Value range	Default	Units
0 ... 99.9	NaCl ... 15.0 CaCl ₂ ... 12.5 MgCl ₂ ... 12.5 Custom ... 0.0	% m/v

B-C-F Set-point range +/-

dp-set-point-range

The acceptable tolerance of the solute concentration set-point.

Value range	Default	Units
0 ... 99.9	1.0	% m/v

B-D Custom medium settings

B-D-A Set-point

dp-set-point

The target concentration of the solute.



Value range	Default	Units
0 ... 99.9	NaCl ... 22.0 CaCl ₂ ... 26.0 MgCl ₂ ... 26.0 Custom ... 0.0	% m/v

B-D-B Minimum set-point

dp-minimum-set-point

The minimum solute concentration to which the set point can be adjusted. If the concentration set point entered over the LC-Display MD-10 is lower, it is set to this value.

Value range	Default	Units
0 ... 99.9	NaCl ... 15.0 CaCl ₂ ... 12.5 MgCl ₂ ... 12.5 Custom ... 0.0	% m/v

B-D-C Maximum set-point

dp-maximum-set-point

The maximum solute concentration to which the set point can be adjusted. If the concentration set point entered over the LC-Display MD-10 is higher, it is set to this value.

Value range	Default	Units
0 ... 99.9	NaCl ... 25.0 CaCl ₂ ... 37.5 MgCl ₂ ... 37.5 Custom ... 99.9	% m/v

B-D-D IOU1 concentration span

dp-analog-out-iout1-concentration-span

The span of the solute concentration that corresponds to the 4 ... 20 mA output of the analog IOU1.

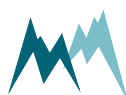

Value range	Default	Units
0 ... 100	NaCl ... 10.0 CaCl ₂ ... 25.0 MgCl ₂ ... 25.0 Custom ... 99.9	% m/v

B-D-E IOUT1 concentration min. value

dp-analog-out-iout1-concentration-min-value

The solute concentration that corresponds to the 4 mA output of the analog IOUT1.

Value range	Default	Units
0 ... 99.9	NaCl ... 15.0 CaCl ₂ ... 12.5 MgCl ₂ ... 12.5 Custom ... 0.0	% m/v

B-D-F Set-point range +/-

dp-set-point-range

The acceptable tolerance of the solute concentration set-point.

Value range	Default	Units
0 ... 99.9	1.0	% m/v

B-D-G User tables

B-D-G-A Num. of temperatures

dp-num-temperatures

Number of temperatures for which the density of the custom medium is defined. This determines the length of [Temperature table](#) and the number of columns in [Density table](#).

Value range	Default	Units
2 ... 26	20	-

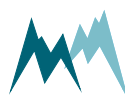

B-D-G-B Temperature table

dp-temperature-table

The temperatures for which the density of the custom medium is defined. Its length is defined by [Num. of temperatures](#).

Value range	Default	Units
-20 ... 100	-	°C

B-D-G-C Num. of concentrations

dp-num-concentrations

Number of concentrations for which the density of the custom medium is defined. This determines the length of [Concentration table](#) and [Density table](#).

Value range	Default	Units
2 ... 50	20	-

B-D-G-D Concentration table

dp-concentration-table

The solute concentrations for which the density of the custom medium is defined. Its length is defined by [Num. of concentrations](#).

Value range	Default	Units
0 ... 100	-	% m/v

B-D-G-E Density table

dp-density-table

The solute concentrations for which the density of the custom medium is defined. Its length is defined by [Num. of concentrations](#).

Value range	Default	Units
-1 ... 2000000	-1	$\mu\text{g}/\text{cm}^3$ (equivalent to g/m^3)

B-D-H Medium name

dp-medium-name

The name of the custom medium. Can be max. 12 characters long.

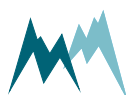

C Technics

C-A	Language/Sprache	108
C-B	Decimal character	108
C-C	Units and decimals	109
C-D	Density measurement	109
C-E	Measurement range monitoring	110
C-F	Mixer controller	110
C-G	Temperature	111
C-H	IOUT settings	112
C-I	Advanced settings	114
C-J	SDI-12 service	115
C-K	Measurement output interval	116
C-L	RS-485-1 Protocol	116
C-M	RS-485-1 Port	119
C-N	RS-485-2 Port	122

C-A Language/Sprache

`generic-language`

The menu language.

ID	Option	Description
1	German/Deutsch	German language
2	English/Englisch (default)	English language

C-B Decimal character

`generic-decimals-character`

The character used as decimal separator in the values of the settings, in serial data strings and in .csv files.

ID	Option	Description
1	Comma	-
2	Dot (default)	-

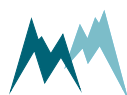

C-C Units and decimals

C-C-A	Temperature, unit	109
-------	-------------------------	-----

C-C-A Temperature, unit

generic-units-temperature

The unit of the medium temperature.

ID	Option	Description
1	°C (default)	Degrees Celsius
2	°F	Fahrenheit

C-D Density measurement

C-D-A Adjustment active

dp-adjustment-active

Switch to perform a density or concentration adjustment.

ID	Option	Description
1	no	The DP-20 runs in normal, continuous measurement mode.
2	yes	A density or concentration adjustment is performed.

C-D-B Concentration adjustment

dp-concentration-adjustment

The solute concentration of the medium that is used for adjustment.

Value range	Default	Units
0 ... 99.9	0.0	% m/v

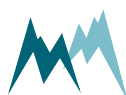

C-D-C Density adjustment

`dp-density-adjustment`

The density of the medium that is used for adjustment.

Value range	Default	Units
0 ... 2	0.0	g/cm ³

C-E Measurement range monitoring

C-E-A Delay 'Out of range'

`dp-delay-out-range`

The delay before the status *Concentration is out of range* is returned.

Value range	Default	Units
0.1 ... 3600	6.0	sec

C-F Mixer controller

C-F-A Proportional factor

`dp-proportional-factor`

Proportional factor of the PD control loop used for solute mixing.

Value range	Default	Units
0 ... 10000	200	-

C-F-B Differential factor

`dp-differential-factor`

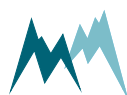

Differential factor of the PD control loop used for solute mixing.

Value range	Default	Units
0 ... 10000	200	-

C-F-C Control interval

`dp-control-interval`

Interval of the PD control loop used for solute mixing.

Value range	Default	Units
0 ... 30	5	sec

C-F-D Minimum pulse length

`dp-minimum-pulse-length`

The minimum duration the switch outputs for the mixing control, OUT3 and OUT4, are active.

Value range	Default	Units
0.1 ... 20	0.1	sec

C-F-E Input delay

`dp-input-delay`

Delay after the mixing signal received on control input IN1 and start of the mixing control. This delay enables the medium flow to stabilize.

Value range	Default	Units
0 ... 60	4	sec

C-G Temperature

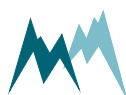

C-G-A Medium temperature offset

`dp-medium-temperature-offset`

The difference between the medium temperatures measured by the DP-20 and a reference sensor.

Value range	Default	Units
-99.9999 ... 999.9999	0	°C

C-G-B Internal temperature offset

`dp-internal-temperature-offset`

The difference between the device temperatures measured by the DP-20 and a reference sensor.

Value range	Default	Units
-99.9999 ... 999.9999	0	°C

C-G-C Test temperatures

`dp-test-temperatures`

Function to test the medium and device temperatures.

C-G-D Adjust temperatures

`dp-adjust-temperatures`

Function to adjust the medium and device temperatures. Applying this function will update the settings [Medium temperature offset](#) and [Internal temperature offset](#).

C-H IOUT settings

C-H-A	IOUT1, output option	113
C-H-B	IOUT1, output parameter	113
C-H-C	IOUT1, density span	113
C-H-D	IOUT1, density min. value	113
C-H-E	IOUT2, 4-20 mA span	114
C-H-F	IOUT2, 4 mA value	114
C-H-G	Simulate current output	114

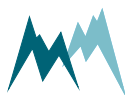

C-H-A IOOUT1, output option

dp-analog-out-iout1-output-option

The signal type of the analog output IOOUT1.

ID	Option	Description
1	4-20 mA	Current output 4 ... 20 mA
2	0-20 mA	Current output 0 ... 20 mA
3	0-10 V	Voltage output 0 ... 10 VDC

C-H-B IOOUT1, output parameter

dp-analog-out-iout1-output-parameter

The variable returned by the analog output IOOUT1.

ID	Option	Description
1	density	The medium density is returned.
2	concentration (default)	The solute concentration is returned.

C-H-C IOOUT1, density span

dp-analog-out-iout1-density-span

The span of the medium density that corresponds to the span of the selected output signal.

Value range	Default	Units
0 ... 9999999.9	0.400	g/cm ³

C-H-D IOOUT1, density min. value

dp-analog-out-iout1-density-min-value

The minimum of the medium density that corresponds to the minimum value of the selected output signal.

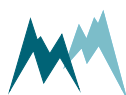

Value range	Default	Units
0 ... 9999999.9	1.0000	g/cm ³

C-H-E IOU2, 4-20 mA span

`dp-analog-out-iout2-span`

The span of the medium temperature that corresponds to the span of 4 ... 20 mA output signal.

Value range	Default	Units
0 ... 999999.9	100	°C

C-H-F IOU2, 4 mA value

`dp-analog-out-iout2-4ma-value`

The minimum medium temperature that corresponds to 4 mA of the output signal.

Value range	Default	Units
-99999.9 ... 999999.9	-20	°C

C-H-G Simulate current output

`generic-analog-out-simulate-current`

With this function the analog outputs can be simulated. Upon submission of a current value between 4 and 20 mA the corresponding values of the selected variable are displayed. The selected current is also applied to the analog outputs and can be read with a connected data logger or multimeter. By pressing Return/Enter again the simulation stops.

C-I Advanced settings

C-I-A Sommer ID 114

C-I-A Sommer ID

`generic-sommer-id`

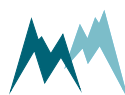

The Sommer ID is used to define stations within the Commander software. The ID is preset in the device and corresponds to its serial number. SOMMER suggests not to change the ID, except if a DP-20 device is replaced. In such a case it can be practical to change the ID of the new device to the ID of the replaced device to guarantee data consistency.

C-J SDI-12 service

C-J-A	SDI-12 address	115
C-J-B	SDI12 Information	115
C-J-C	SDI12 'M'-response	115

C-J-A SDI-12 address

`generic-sdi-12-address`

The address is a unique identifier of the sensor within a SDI-12 bus system.

Value range	Default	Units
0...9, a...z, A...Z	0	-

C-J-B SDI12 Information

`generic-sdi-12-information`

The scope of the data output.

ID	Parameter	Description
1	main values (default)	Only main values are returned.
2	& special values	Main values and special values are returned.
3	& analysis values	Main, special and analysis values are returned.

C-J-C SDI12 'M'-response

`generic-sdi-12-m-response`

Defines how an SDI-12 M-command received by the DP-20 is answered if the requested number of measurement values exceeds 9. The following options are available:

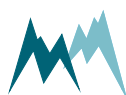

ID	Parameter	Description
1	expand address	This option should only be used with SDI-12 standard V1.0. The measurement values can be requested with the commands <code>aD0 !</code> , <code>aD1 !</code> , ..., with <code>a</code> the sensor address. Max. 9 values are returned for each command.
2	just expand output	The <code>M</code> -request received by the DP-20 is answered according to SDI-12 standard V1.3, which supports transmitting more than 9 measurement values per answer.
3	as at 'C' request	The <code>M</code> -request received by the DP-20 is answered as if several <code>C</code> -requests were sent.
4	M1, M2, M3 split (default)	The <code>M</code> -request received by the DP-20 is answered as if several <code>M_k</code> -commands were sent, with <code>k</code> depending on the number of measurement values to be transmitted (<code>M1</code> returns the first 9 measurement values, <code>M2</code> the second nine values, etc).

C-K Measurement output interval

`dp-measurement-output-interval`

The interval at which the measurement data are pushed to the serial output port.

Value range	Default	Units
1 ... 5	2	sec

C-L RS-485-1 Protocol

The RS-485-1 interface is used to read acquired data and to configure the DP-20. The following parameters are available to configure the protocol; the port settings are defined in [RS-485-1 Port](#).

C-L-A	Device number	117
C-L-B	System key	117
C-L-C	Output protocol (OP)	117
C-L-D	Measurement output	118
C-L-E	Information	118
C-L-F	Wake-up sequence	118
C-L-G	Prefix holdback	119



C-L-A Device number

`generic-rs-485-protocol-device-number`

The device number is used for the unique identification of the device in a bus system.

Value range	Default	Units
0...98	1 (default)	-

C-L-B System key

`generic-rs-485-protocol-system-key`

The system key defines the bus system of the device. Thus, different conceptual bus systems can be separated. Interfering bus systems occur if the remote radio coverage of two measurement systems overlap. In general, the system key should be set to 00.

Value range	Default	Units
0...99	0	-

C-L-C Output protocol (OP)

`generic-rs-485-protocol-output-protocol`

The type of the serial output protocol. The following options are available:

ID	Option	Description
1	Sommer (SBP) (default)	Sommer Bus Protocol; data values are returned with an index starting at 1. Multiple strings may be returned.
2	Standard	Standard protocol; data values are returned without an index in one string.
3	MODBUS	Modbus protocol



NOTE For MODBUS applications run `MODBUS`, set `default` to get the appropriate communication settings.

C-L-D Measurement output

`generic-rs-485-protocol-measurement-output`

Specifies the timing of the serial data output.

ID	Option	Description
1	just per command	The output is only requested by commands via the RS-485 or SDI-12 interface.
2	after measurement (default)	The serial data output is performed automatically right after each measurement.

C-L-E Information

`generic-rs-485-protocol-information`

The main measurement values are always included in the data output string. Additionally, special and analysis values can be included.

ID	Option	Description
1	Main values	Only the main values are returned.
2	& Special values (default)	Main values and special values are returned.
3	& Analysis values	Main, special and analysis values are returned.

C-L-F Wake-up sequence

`generic-rs-485-protocol-wake-up-sequence`

Serial data can be transmitted to a recording device automatically without a request. However, many devices demand a wake-up sequence before they can receive and process data. The DP-20 has the option to send a sync sequence and a prefix before data are transmitted. The following options are available:

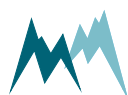

ID	Option	Description
1	Off	No wake-up sequence
2	Sync	The sync sequence UU~?~? is sent before the output string.
3	Prefix (default)	A blank with a time delay is sent before the output string.
4	Prefix & Sync	A blank with a time delay and the sync sequence UU~?~? is sent before the output string.

C-L-G Prefix holdback

`generic-rs-485-protocol-prefix-holdback`

The hold-back time defines the time delay between the prefix and the data string.

Value range	Default	Units
0...5'000	300	ms

C-M RS-485-1 Port

C-M-A	Baudrate	119
C-M-B	Parity, stop bits	120
C-M-C	Minimum response time	120
C-M-D	Transmitter warm-up time	121
C-M-E	Flow control	121
C-M-F	Sending window	121
C-M-G	Receiving window	121

C-M-A Baudrate

`generic-rs-485-port-baud-rate`

The following transmission rates in bps (baud) can be selected:

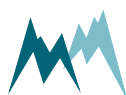

ID	Option	Description
1	1'200	-
2	2'400	-
3	4'800	-
4	9'600 (default for sensors and data logger inputs)	-
5	19'200 (default if used with radio communication)	-
6	38'400	-
7	57'600	-
8	115'200 (default for data loggers)	-

C-M-B Parity, stop bits

`generic-rs-485-port-parity-stop-bits`

The following combinations of parity and stop bits can be selected:

ID	Option	Description
1	No par, 1 stop (default)	No parity and 1 stop bit
2	No par, 2 stop	No parity and 2 stop bits
3	Even par, 1 stop	Even parity and 1 stop bit
4	Odd par, 1 stop	Odd parity and 1 stop bit

C-M-C Minimum response time

`generic-rs-485-port-minimum-response-time`

This setting avoids failures of half-duplex interfaces. For this purpose the response to a command is delayed by the selected time. Additionally, the response is also kept temporally compact.

Value range	Default	Units
0...2'000	10	ms

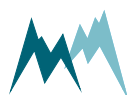

C-M-D Transmitter warm-up time

`generic-rs-485-port-transmitter-warm-up-time`

The transmitter warm-up time defines the time before data is sent.

Value range	Default	Units
0...2'000	10	ms

C-M-E Flow control

`generic-rs-485-port-flow-control`

Flow control for the defined application.

ID	Option	Description
1	Off	no flow control
2	XOFF-XON blocking (default)	XOFF-XON flow control, especially adapted for half-duplex systems
4	DFM-RC	Flowcontrol for Sommer Messtechnik DFM point-to-point radios.
5	DFM-TM	Flowcontrol for Sommer Messtechnik DFM tiny-mesh radios.

C-M-F Sending window

`generic-rs-485-port-sending-window`

If XON-XOFF flow control is activated data are transmitted in blocks with the defined length.

Value range	Default	Units
200...5'000	300	ms

C-M-G Receiving window

`generic-rs-485-port-receiving-window`

If XON-XOFF flow control is activated transmission of blocks is delayed by the specified time.

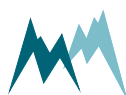

Value range	Default	Units
200...5'000	300	ms

C-N RS-485-2 Port

The RS-485-2 interface is used to read data from connected digital sensors. The following parameters are available to configure it.

C-N-A	Baudrate	122
C-N-B	Parity, stop bits	122
C-N-C	Minimum response time	123
C-N-D	Transmitter warm-up time	123
C-N-E	Flow control	123
C-N-F	Sending window	124
C-N-G	Receiving window	124
C-N-H	Parallel measurement output	124
C-N-I	MODBUS, set default	125
C-N-J	MODBUS, device address	125

C-N-A Baudrate

`generic-rs-485-port-baud-rate`

The following transmission rates in bps (baud) can be selected:

ID	Option	Description
1	1'200	-
2	2'400	-
3	4'800	-
4	9'600 (default for sensors and data logger inputs)	-
5	19'200 (default if used with radio communication)	-
6	38'400	-
7	57'600	-
8	115'200 (default for data loggers)	-

C-N-B Parity, stop bits

`generic-rs-485-port-parity-stop-bits`

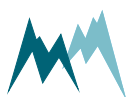

The following combinations of parity and stop bits can be selected:

ID	Option	Description
1	No par, 1 stop (default)	No parity and 1 stop bit
2	No par, 2 stop	No parity and 2 stop bits
3	Even par, 1 stop	Even parity and 1 stop bit
4	Odd par, 1 stop	Odd parity and 1 stop bit

C-N-C Minimum response time

`generic-rs-485-port-minimum-response-time`

This setting avoids failures of half-duplex interfaces. For this purpose the response to a command is delayed by the selected time. Additionally, the response is also kept temporally compact.

Value range	Default	Units
0...2'000	10	ms

C-N-D Transmitter warm-up time

`generic-rs-485-port-transmitter-warm-up-time`

The transmitter warm-up time defines the time before data is sent.

Value range	Default	Units
0...2'000	10	ms

C-N-E Flow control

`generic-rs-485-port-flow-control`

Flow control for the defined application.

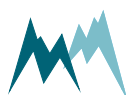

ID	Option	Description
1	Off	no flow control
2	XOFF-XON blocking (default)	XOFF-XON flow control, especially adapted for half-duplex systems
4	DFM-RC	Flowcontrol for Sommer Messtechnik DFM point-to-point radios.
5	DFM-TM	Flowcontrol for Sommer Messtechnik DFM tiny-mesh radios.

C-N-F Sending window

`generic-rs-485-port-sending-window`

If XON-XOFF flow control is activated data are transmitted in blocks with the defined length.

Value range	Default	Units
200...5'000	300	ms

C-N-G Receiving window

`generic-rs-485-port-receiving-window`

If XON-XOFF flow control is activated transmission of blocks is delayed by the specified time.

Value range	Default	Units
200...5'000	300	ms

C-N-H Parallel measurement output

`mrl-parallel-measurement-output`

Switch to enable additional serial data output on the [RS-485-2 Port](#).

ID	Setting	Description
1	off (default)	Data are only returned on the RS-485-1 Port
2	on	Data are returned on the RS-485-1 Port and the RS-485-2 Port

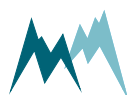

C-N-I MODBUS, set default

`generic-rs-485-protocol-modbus-set-default`

Sets all parameters required for Modbus communication automatically. The following settings are adapted:

Parameter	Modbus setting
OP, measurement output	just per command
Output protocol (OP)	Modbus
MODBUS, device address	35
Sleep mode	Modbus, slow
Parity, stop bits	even par, 1 stop
Baud rate	19200
Flow control	off
Transmitter warm-up time	10 ms
Minimum response time	30 ms

C-N-J MODBUS, device address

`generic-rs-485-protocol-modbus-device-address`

Unique device address for the Modbus protocol.

Value range	Default	Units
1...247	35	-

D Special functions

D-A	Device status	125
D-B	Set factory default	126
D-C	Temp. load factory default	126
D-D	Relaunch program	126
D-E	Replace program	126

D-A Device status

`generic-special-functions-device-status`

Displays information about the device and the software version.

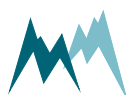

D-B Set factory default

`generic-special-functions-set-factory-default`

All parameters are reset to factory defaults. Only available in terminal-mode.

D-C Temp. load factory default

`generic-special-functions-temp-load-factory-default`

Loads factory default values temporarily. Only available in terminal mode.

D-D Relaunch program

`generic-special-functions-relaunch-program`

The device is restarted. Powering the device off and on again is equivalent.

D-E Replace program

`generic-special-functions-replace-program`

The device is set into a "Boot Loader" mode for three minutes to upload new software remotely in case supply off and on again is not applicable.

E Measurement table

`dp-measurement-table`

Lists all measured variables with their units.

Index	Measurement value	Unit	Description
01	Temp. medium	°C	Temperature of the medium
02	Density	g/cm ³	Density of the medium
03	Concentration	%	Concentration of the solute
04	Set value	%	Target value of the solute concentration
05	Status	-	Status of the DP-20

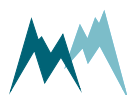

Appendix O Troubleshooting

0.1	Devices	127
0.1.1	The DP-20 is not responding or returns unreadable characters	127
0.1.2	The DP-20 reboots repeatedly	129
0.2	Measurement data	129
0.2.1	Measurement data are not updated	129
0.2.2	DP-20 reports a medium error	129
0.2.3	DP-20 reports a temperature error	129
0.3	Firmware & software	130
0.3.1	Commander loads wrong setup	130
0.3.2	Firmware update via RS-485 is aborted	130
0.4	RS-485	130
0.4.1	Configuration via terminal shows unexpected behavior	130
0.5	SDI-12	131
0.5.1	The DP-20 is not detected by a SDI-12 master device	131
0.5.2	Data logger receives no SDI-12 data	131
0.6	Analog output	131
0.6.1	The 4-20 mA output is wrong	131

O.1 Devices

O.1.1 The DP-20 is not responding or returns unreadable characters

Reason	Solution
The power supply is not connected or turned off.	Check if the power supply is connected and on.
The polarity of connected power supply wires is wrong.	Check the polarity of connected wires.
Wrong sensor cable.	Use the original sensor cable configured by Sommer Messtechnik (only applicable to Sommer Messtechnik cables).
Power supply is insufficient. The DP-20 requires a certain inrush-current that the power supply is not able to provide.	<ol style="list-style-type: none"> 1. Use a power supply providing >0.5 A at 12 VDC or a fully charged battery. 2. In case of long sensor cables (>50 m) use a 24-VDC power supply. <p>Please note that power supplied by the USB-port is insufficient to power the DP-20!</p>
The power supply voltage is out of range.	Adjust the power supply to match the specified voltage range.

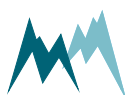

Reason	Solution
The polarity of the connected RS-485-A and RS-485-B wires is wrong.	Reverse the polarity of the connected RS-485-A and RS-485-B wires.
The port settings of the DP-20 and the data acquisition system do not match.	Use the Commander Communication assistant or adapt port settings on your device.  NOTE Sommer Messtechnik devices require the following Baud rates: <ul style="list-style-type: none"> ■ Sensor: 9600 ■ Data logger: 115200 ■ Modbus: 19200 In case of doubt use the function Check port in the Communication assistant .
The DP-20 is set to Modbus.	Connect to the sensor using the Communication assistant of the Commander and select the Modbus option in the Serial connection .
A sensor wire is not connected firmly to the terminal of the data acquisition device.	Check the firm connection of the sensor wires.
DP-20 and data acquisition device have different grounds.	Connect the grounds of the DP-20 and the data acquisition device.
A pin of the connector plug is bent or broken.	Verify that all connector pins are straight.
The sensor cable is damaged.	Replace the sensor cable.
The COM-port has not been assigned correctly to the USB converter.	<ol style="list-style-type: none"> 1. Make sure to use a Sommer Messtechnik USB converter. Third party converters are not supported. 2. Check the COM-port number using Windows Device Manager. 3. Plug in the USB converter first, then start Commander.
The USB converter is faulty.	Replace the USB converter.
The USB port on your PC is not working.	Use another USB port.
The driver of the USB converter was incorrectly installed	Reinstall the driver of the USB converter.

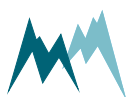

O.1.2 The DP-20 reboots repeatedly

Reason	Solution
The power supply has not enough current to start the DP-20.	Verify that the power supply provides enough current. A DP-20 consumes up to 140 mA @ 12 V. If required, power the DP-20 by an additional or alternative supply.

O.2 Measurement data

O.2.1 Measurement data are not updated

The device is connected to the Commander, but the data are not updated.

Reason	Solution
Data traffic conflict	Reboot the device by interrupting the power supply.

O.2.2 DP-20 reports a medium error

Cause	Solution
A pipe fitting is not tight and air is drawn into the medium.	Check if the pipe fittings upstream of the DP-20 are tight.

O.2.3 DP-20 reports a temperature error

Cause	Solution
One of the temperature sensors is malfunctioning or broken.	Contact Sommer Messtechnik for further advice.

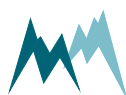

O.3 Firmware & software

O.3.1 Commander loads wrong setup

If the setup is reloaded from the device the Commander seems to display an old version.

Cause	Solution
The device has been connected to the same PC before and several different setup files have been loaded.	<ul style="list-style-type: none"> In the Communication section of the Commander, select Mode Connection and click on the trash can icon on the right edge. Then, reload the setup from the device. Delete the setup files of the device that have been downloaded by Commander to the folder <code>C:\Users\Public\Documents\Sommer\Setup</code>. The respective files can be identified by the serial number in the file name and the file date.

O.3.2 Firmware update via RS-485 is aborted

Reason	Solution
USB to RS-485 converter cable is damaged or can only operate on 9600 baud.	Replace USB to RS-485 converter cable. The programmer requires 57600 baud.

O.4 RS-485

O.4.1 Configuration via terminal shows unexpected behavior

Accessing the parameter menus in the terminal leads to unexpected behavior, e.g. after entering a menu character the terminal displays repeated error messages or jumps out of the parameter menu.

Reason	Solution
The sensor, power supply and PC/laptop do not share the same ground.	Verify that all equipment is connected to the same ground.

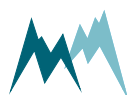

O.5 SDI-12

O.5.1 The DP-20 is not detected by a SDI-12 master device

Reason	Solution
The DP-20 and the SDI-12 master have different grounds.	Verify that the DP-20 and the SDI-12 master are connected by a ground (GND) wire.

O.5.2 Data logger receives no SDI-12 data

Reason	Solution
The sensor is set to <i>Measurement trigger interval</i> , but the data logger sends a M! command, i.e. the data logger polls data.	If data are polled from the sensor, <i>Measurement interval</i> must be set to <i>SDI-12/RS485</i> .
The sensor is set to <i>Measurement trigger SDI-12/RS485</i> , but the data logger sends an R! command, i.e. the sensor pushes data.	If the sensor pushes data, <i>Measurement interval</i> must be set to <i>interval</i> .

O.6 Analog output

O.6.1 The 4-20 mA output is wrong

Reason	Solution
Analog output settings incorrect.	<ol style="list-style-type: none"> 1. Check analog output settings. 2. Run <i>Simulate current output</i> and verify the correct output.
Sensor and data acquisition system have different grounds.	Verify that sensor and data acquisition system have the same ground.
The analog output is read by a data acquisition system and the scaling is wrong.	Verify scale and offset on your data acquisition system.



Reason	Solution
Two or more analog outputs of the DP-20 are read by a data acquisition system and the wiring is wrong, e.g. IOUT1 is read as IOUT2.	Verify the wiring on your data acquisition system and swap the wires if required.
The 4-20 mA output is delayed by approx. 150 ms. If the output is read before, a wrong value is acquired.	Sample the 4-20 mA output with a delay of more than 150 ms.



Appendix P CRC-16 array

CRC-16 array

```
1  crc16tab[] =
2  {
3  0x0000, 0x1021, 0x2042, 0x3063, 0x4084, 0x50A5, 0x60C6, 0x70E7,
4  0x8108, 0x9129, 0xA14A, 0xB16B, 0xC18C, 0xD1AD, 0xE1CE, 0xF1EF,
5  0x1231, 0x0210, 0x3273, 0x2252, 0x52B5, 0x4294, 0x72F7, 0x62D6,
6  0x9339, 0x8318, 0xB37B, 0xA35A, 0xD3BD, 0xC39C, 0xF3FF, 0xE3DE,
7  0x2462, 0x3443, 0x0420, 0x1401, 0x64E6, 0x74C7, 0x44A4, 0x5485,
8  0xA56A, 0xB54B, 0x8528, 0x9509, 0xE5EE, 0xF5CF, 0xC5AC, 0xD58D,
9  0x3653, 0x2672, 0x1611, 0x0630, 0x76D7, 0x66F6, 0x5695, 0x46B4,
10 0xB75B, 0xA77A, 0x9719, 0x8738, 0xF7DF, 0xE7FE, 0xD79D, 0xC7BC,
11 0x48C4, 0x58E5, 0x6886, 0x78A7, 0x0840, 0x1861, 0x2802, 0x3823,
12 0xC9CC, 0xD9ED, 0xE98E, 0xF9AF, 0x8948, 0x9969, 0xA90A, 0xB92B,
13 0x5AF5, 0x4AD4, 0x7AB7, 0x6A96, 0x1A71, 0x0A50, 0x3A33, 0x2A12,
14 0xDBFD, 0xCBDC, 0xFBBF, 0xEB9E, 0x9B79, 0x8B58, 0xBB3B, 0xAB1A,
15 0x6CA6, 0x7C87, 0x4CE4, 0x5CC5, 0x2C22, 0x3C03, 0x0C60, 0x1C41,
16 0xEDAE, 0xFD8F, 0xCDEC, 0xDDCD, 0xAD2A, 0xBD0B, 0x8D68, 0x9D49,
17 0x7E97, 0x6EB6, 0x5ED5, 0x4EF4, 0x3E13, 0x2E32, 0x1E51, 0x0E70,
18 0xFF9F, 0xEFBE, 0xDFDD, 0xCFFC, 0xBF1B, 0xAF3A, 0x9F59, 0x8F78,
19 0x9188, 0x81A9, 0xB1CA, 0xA1EB, 0xD10C, 0xC12D, 0xF14E, 0xE16F,
20 0x1080, 0x00A1, 0x30C2, 0x20E3, 0x5004, 0x4025, 0x7046, 0x6067,
21 0x83B9, 0x9398, 0xA3FB, 0xB3DA, 0xC33D, 0xD31C, 0xE37F, 0xF35E,
22 0x02B1, 0x1290, 0x22F3, 0x32D2, 0x4235, 0x5214, 0x6277, 0x7256,
23 0xB5EA, 0xA5CB, 0x95A8, 0x8589, 0xF56E, 0xE54F, 0xD52C, 0xC50D,
24 0x34E2, 0x24C3, 0x14A0, 0x0481, 0x7466, 0x6447, 0x5424, 0x4405,
25 0xA7DB, 0xB7FA, 0x8799, 0x97B8, 0xE75F, 0xF77E, 0xC71D, 0xD73C,
26 0x26D3, 0x36F2, 0x0691, 0x16B0, 0x6657, 0x7676, 0x4615, 0x5634,
27 0xD94C, 0xC96D, 0xF90E, 0xE92F, 0x99C8, 0x89E9, 0xB98A, 0xA9AB,
28 0x5844, 0x4865, 0x7806, 0x6827, 0x18C0, 0x08E1, 0x3882, 0x28A3,
29 0xCB7D, 0xDB5C, 0xEB3F, 0xFB1E, 0x8BF9, 0x9BD8, 0xABBB, 0xBB9A,
30 0x4A75, 0x5A54, 0x6A37, 0x7A16, 0x0AF1, 0x1AD0, 0x2AB3, 0x3A92,
31 0xFD2E, 0xED0F, 0xDD6C, 0xCD4D, 0xBDAA, 0xAD8B, 0x9DE8, 0x8DC9,
32 0x7C26, 0x6C07, 0x5C64, 0x4C45, 0x3CA2, 0x2C83, 0x1CE0, 0x0CC1,
33 0xEF1F, 0xFF3E, 0xCF5D, 0xDF7C, 0xAF9B, 0xBFBA, 0x8FD9, 0x9FF8,
34 0x6E17, 0x7E36, 0x4E55, 0x5E74, 0x2E93, 0x3EB2, 0x0ED1, 0x1EF0
35 }
```

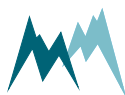

Glossary



Index

